

High Rise Pole Sign
TCHR-12LSSP

6/9/11

SQUARE FOOTAGE	
TYPEFACE	122
INSIDE CAN	211
ENTIRE SIGN	222

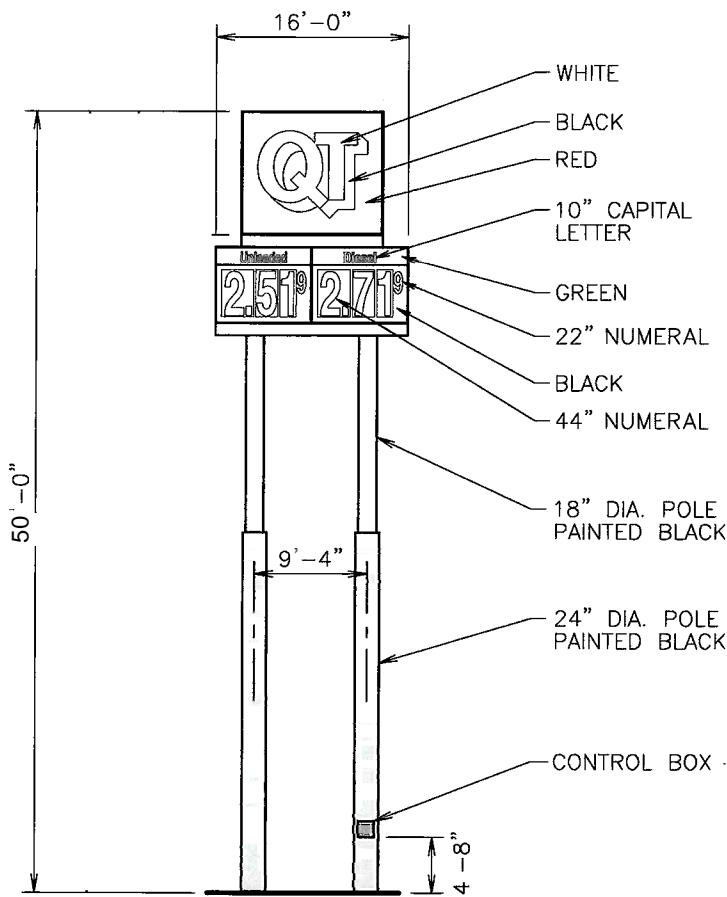

SPECIFICATIONS.

LOGO

3M Translucent Vinyl Face, 3M Cardinal Red Translucent #3632-53, surface applied graphics.

Pricer

Flat Solar grade, Clear Lexan Face, .177 thickness, painted on 2nd surface, Akzo Noble Black, Scrolling Price Numerals, White Helvetica Condensed font, Unlead Product Panels, White text area, painted 2nd surface Akzo Nobel Opaque Black, Auto Diesel Product Panels, White text area, painted 2nd surface to match PMS 7481C Translucent Green, Akzo Noble.

LOGO Cabinet/Pricer Cabinet/Base

Aluminum Construction, Internally illuminated with AI30 LED Lamp Fixture BXCR9002, AI30 Power Supplies BXCR9003. LOGO Cabinet painted Akzo Noble, QT Red SIGN9141 Low Gloss. Pricer Cabinet painted Akzo Noble Black Low Gloss. Accent Trim section painted 1st surface Akzo Noble Silver-Low Gloss.

SCALE

1/16" = 1'-0"

SERIAL NUMBER:

TCHR-12LSSP

STORE NUMBER:

963

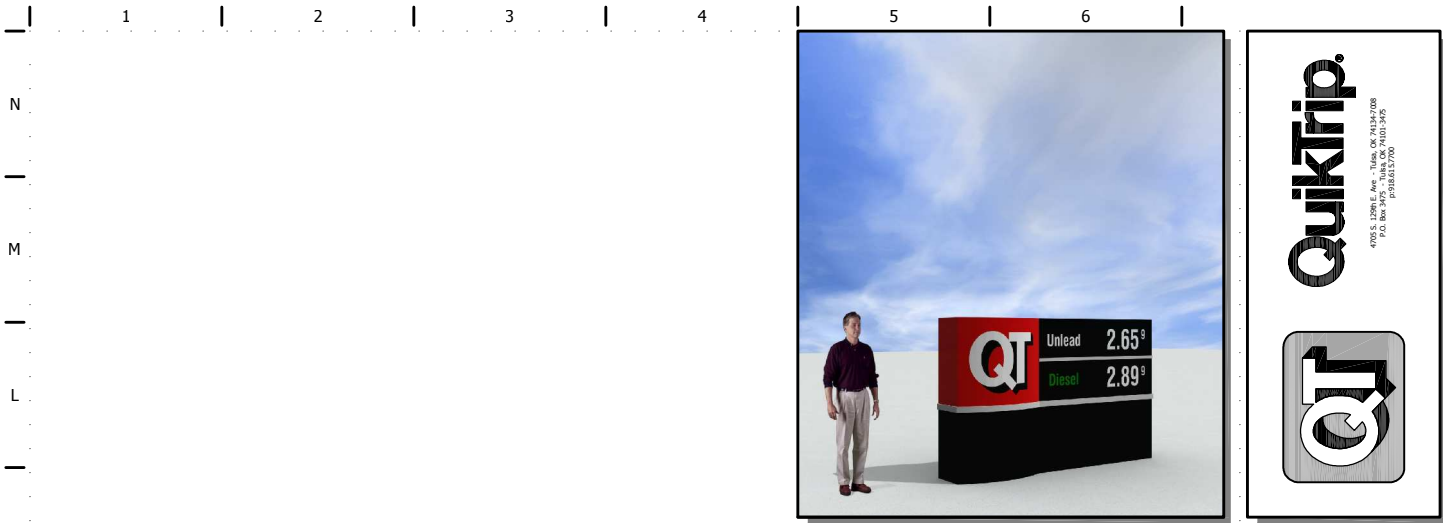

**Horizontal
Monument Sign
MH10-2P30SF**

2/4/11

SQUARE FOOTAGE	TYPEFACE	15
	INSIDE CAN	25
	ENTIRE SIGN	31

SCALE:	
1/4" = 1'-0"	
SERIAL NUMBER:	
MH10-2P30SF	
STORE NUMBER:	

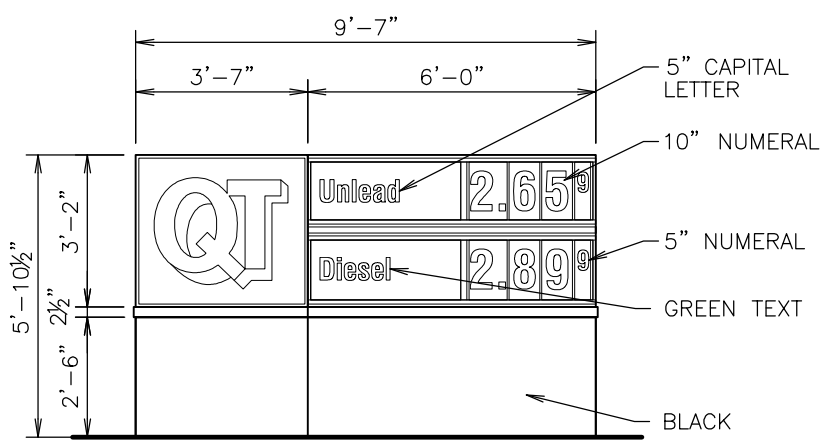
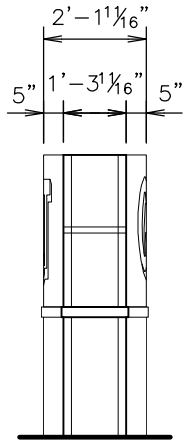

SPECIFICATIONS:	
LOGO	Flat Solar grade, Clear Lexan Face, .177 thickness, painted on 2nd surface to match 3M Cardinal Red Translucent #3632-53, Akzo Nobel, no embossment.
Pricer	Flat Solar grade, Clear Lexan Face, .177 thickness, painted on 2nd surface, Akzo Noble Black, manual Font Numerals, Clear Helvetica Condensed font. Product Panels, Lexan, Clear text area, painted 2nd surface Akzo Nobel Opaque Black, Diesel Product Panel painted 2nd surface to match PMS 7481C Translucent Green, Akzo Noble.
LOGO Cabinet/Pricer Cabinet/Base	Aluminum Construction, Internally illuminated with GE Tetra PowerStrip DS65/GE PS24 Power Supplies. LOGO Cabinet painted Akzo Noble, QT Red SIGN9141 Low Gloss. Pricer Cabinet and Base painted Akzo Noble Black Low Gloss. Accent Trim section painted 1st surface Akzo Noble Silver-Low Gloss.

1 | 2 | 3 | 4 | 5 | 6 |

N
M
L
K
J
I
H
G
F
E
D
C
B
A

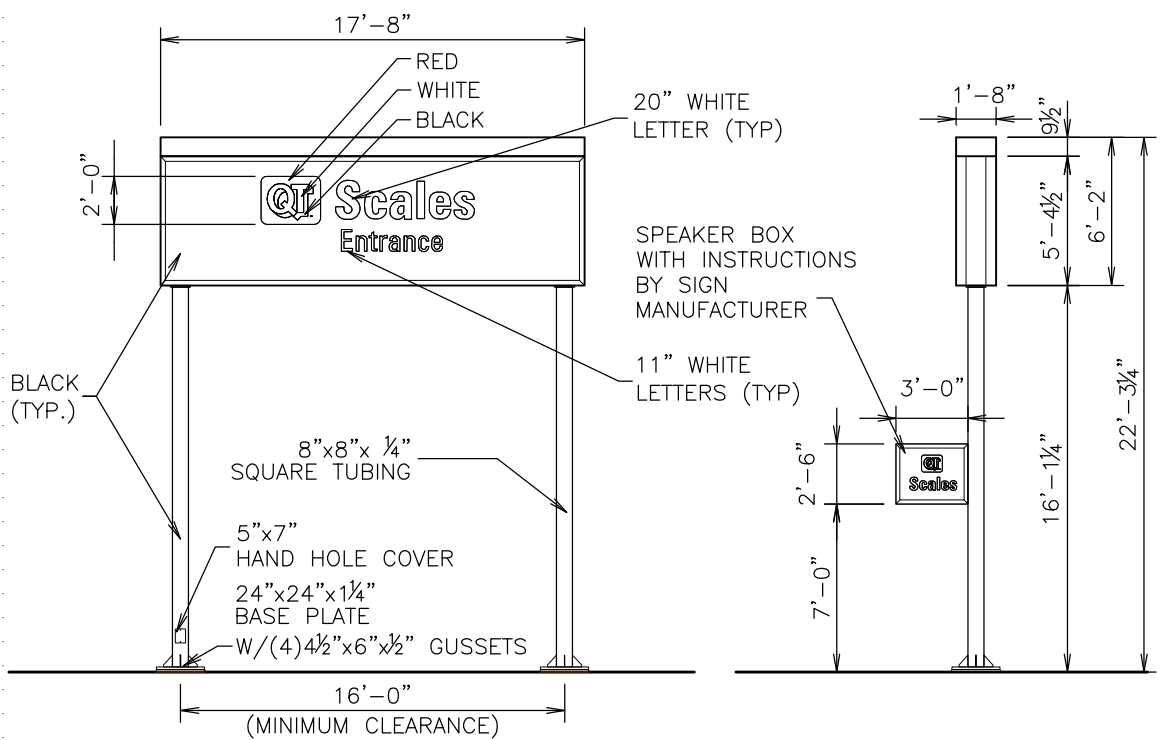
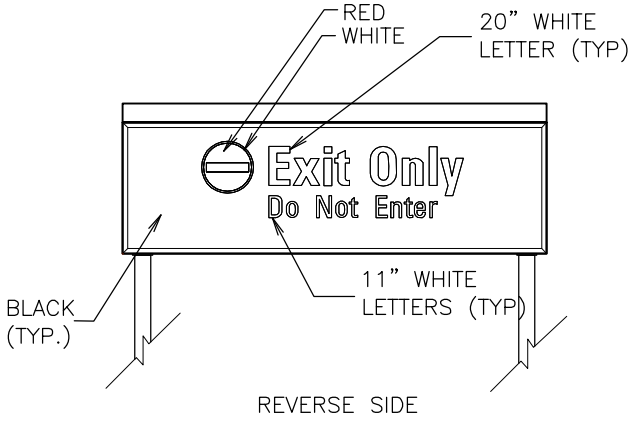
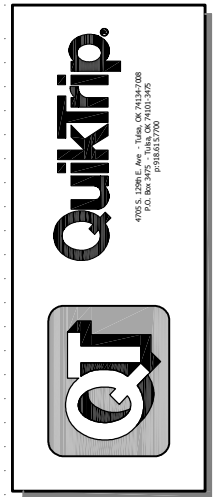
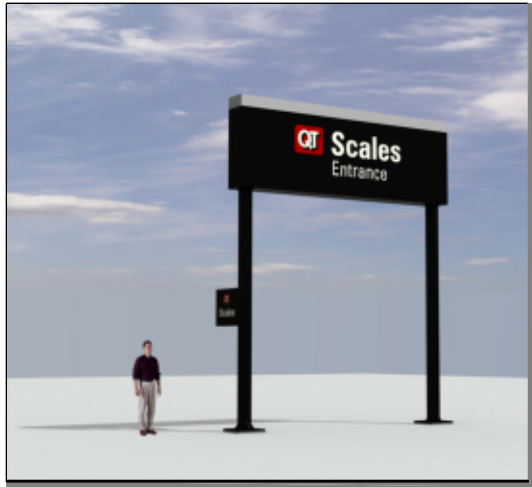

Vertical Pole Sign
TC Scales

04/06/11

SQUARE FOOTAGE	
TYPEFACE	NA
INSIDE CAN	NA
ENTIRE SIGN	96

SPECIFICATIONS:	
Sign Face	Paniflex Face, Background 3M Opaque Black Vinyl, Univers 47 Condensed Light-Bold and Univers 55 Font 3M White Vinyl.
LOGO	Red; Screen Painted to match 3M 3632-53 Cardinal Red Vinyl, White; Screen Painted to match 3M White Vinyl Substrate, Black; Screen Painted to match 3M Black Vinyl.
Sign Cabinet	Aluminum Construction, Internally illuminated with GE Tetra PowerStrip DS65/GE PS24 Power Supplies. Painted Akzo Noble, Black Low Gloss. Accent Trim section painted 1st surface Akzo Noble Silver-Low Gloss.

SCALE:	
1/8" = 1'-0"	
SERIAL NUMBER:	
TC Scales	
STORE NUMBER:	

1 | 2 | 3 | 4 | 5 | 6 |

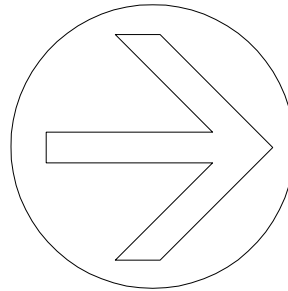
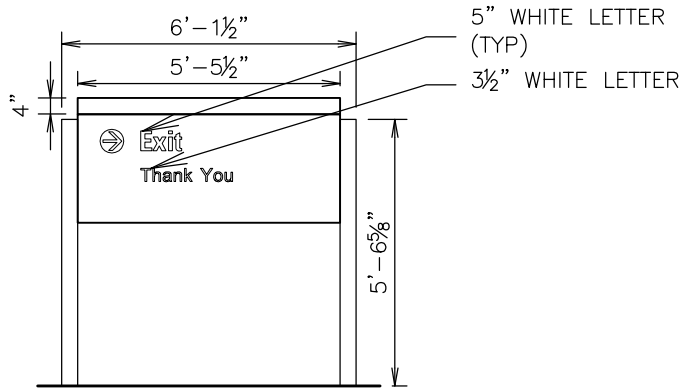
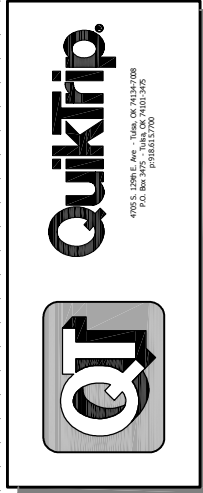

NOTE:
SPECIFY ARROW
DIRECTION UPON
REQUEST

ARROW SCALE: 3"=1'-0"

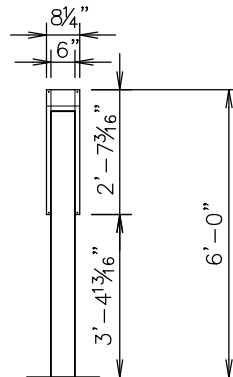
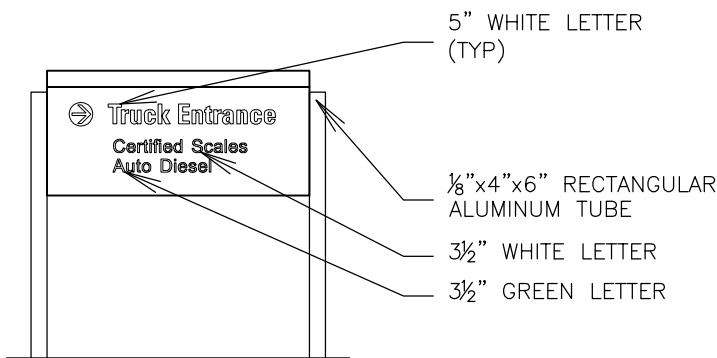

Directional
Pole Sign
TCD-012

06/13/11

SQUARE FOOTAGE	
TYPEFACE	NA
INSIDE CAN	NA
ENTIRE SIGN	12

SPECIFICATIONS:	
Sign Face	Paniflex Face, Background 3M Opaque Black Vinyl, Univers 47 Condensed Light-Bold and Univers 55 Font 3M White Vinyl.
LOGO	Red; Screen Painted to match 3M 3632-53 Cardinal Red Vinyl, White; Screen Painted to match 3M White Vinyl Substrate, Black; Screen Painted to match 3M Black Vinyl.
Sign Cabinet	Aluminum Construction, Internally illuminated with GE Tetra PowerStrip DS65/GE PS24 Power Supplies. Painted Akzo Noble, Black Low Gloss. Accent Trim section painted 1st surface Akzo Noble Silver-Low Gloss.

SCALE:	
1/4" = 1'-0"	
SERIAL NUMBER:	
TCD-012	
STORE NUMBER:	