

- 1** DENOTES PLANNING AREA NUMBER
- DENOTES PLANNING AREA BOUNDARY
- DENOTES INTERSECTING RESIDENTIAL CIRCULATION STREETS - DRIVEWAY ACCESS MAY BE POSSIBLE
- DENOTES INTERSECTING RESIDENTIAL CIRCULATION STREETS - NO DRIVEWAY ACCESS ALLOWED
- o DENOTES EXISTING MEDIAN OPENING LOCATIONS
- DENOTES ACCESS POINTS FOR MAJOR PARCEL ENTRIES. ADDITIONAL MINOR ENTRIES MAY BE ADDED AT PLATTING. POSSIBLE MEDIAN LOCATIONS WILL BE DETERMINED AT TIME OF SITE PLAN REVIEW OF INDIVIDUAL TRACTS

NOTE: NO DRIVEWAY ACCESS WILL BE PERMITTED FOR THE FIRST 200 FEET OFF ARTERIAL ROADWAYS AND FOR THE FIRST 100 FEET OFF OF COLLECTOR STREETS, EXCEPT FOR PA 17 WHICH WILL REQUIRE 120 FEET FOR ACCESS OFF OF COLLECTOR ROADS.

- SF-1 SINGLE FAMILY RESIDENTIAL
- SF-2
- SF-3
- SF-3.5
- MF-1 MULTI FAMILY RESIDENTIAL MEDIUM DENSITY
- MF-2 MULTI FAMILY RESIDENTIAL HIGH DENSITY
- O-1 OFFICE
- O-2
- ML-1 LIGHT MANUFACTURING
- ML-2
- R-1 RETAIL
- R-2
- ES ELEMENTARY SCHOOL
- DENOTES HIKE/BIKE TRAIL
- OS OPEN SPACE
- GC GOLF COURSE

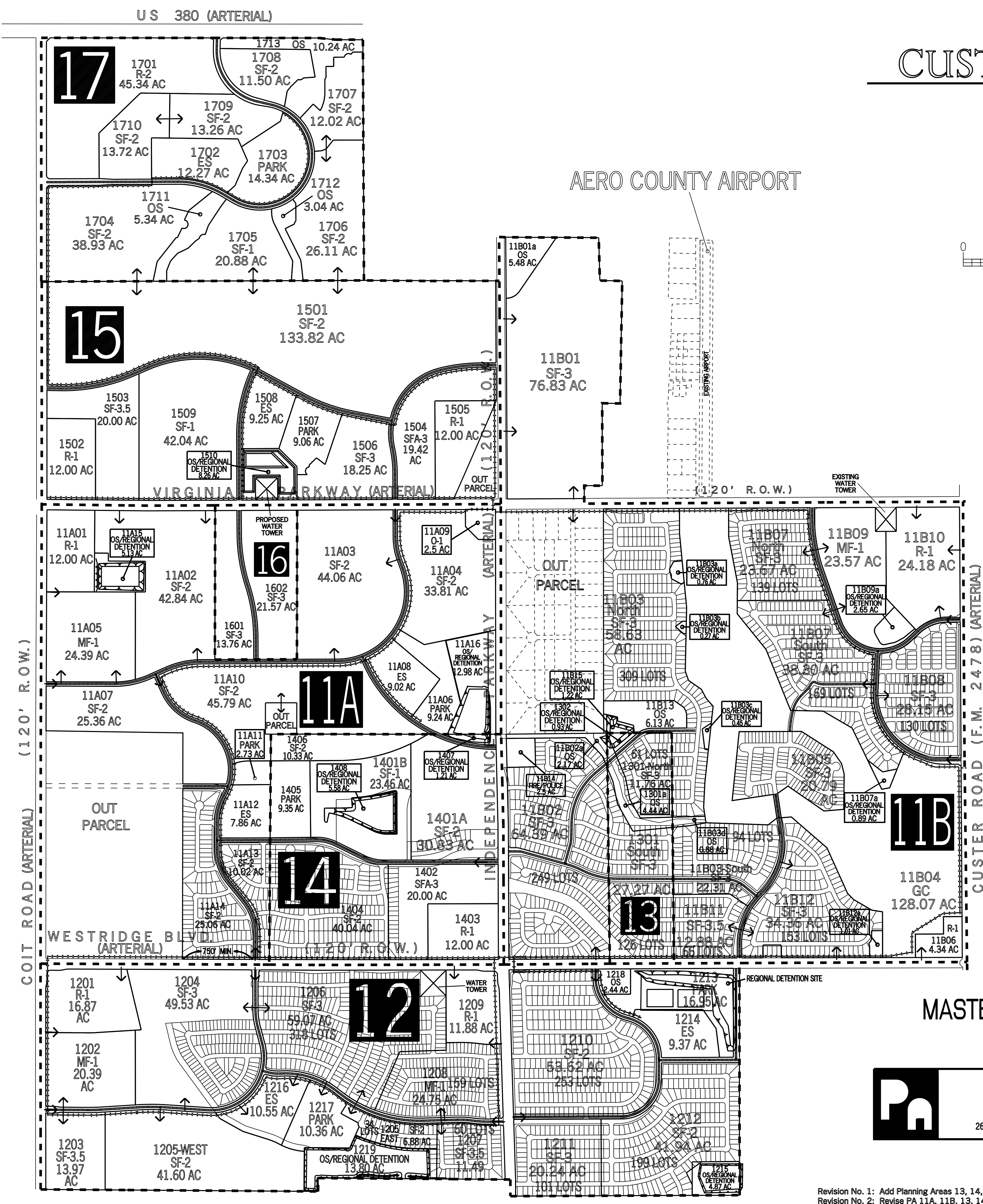

# CUSTER WEST

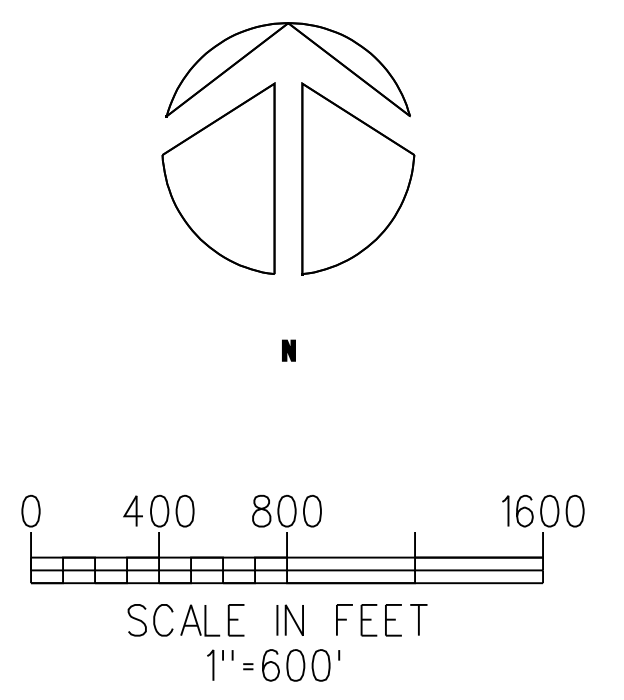

RECEIVED  
OCT 15 2010  
PLANNING

## EXHIBIT A-1

MASTER GENERAL DEVELOPMENT PLAN  
JUNE, 2000

**Pa** PETSCHÉ & ASSOCIATES, INC.  
Professional Engineers - Land Surveyors - Development Consultants  
Texas Registered Engineering Firm F-3252  
2600 Eldorado Pkwy., Suite 240, McKinney, Texas 75070 (972) 562-9606

- Revision No. 1: Add Planning Areas 13, 14, and 15
- Revision No. 2: Revise PA 11A, 11B, 13, 14, & 15 Per City Comments
- Revision No. 3: Add Open Spaces to Planning Areas 11B & 13
- Revision No. 4: Revise Tracts 1401 & 1509 and Collector Streets in PA 11B & 13
- Revision No. 5: Revise Hike & Bike Trail
- Revision No. 6: Revise Tracts 1210, 1211, 1212, 1213, 1214, 1215 & 1218
- Revision No. 7: Revise Tracts 11B03, 11B07 & 1301 to North and South Tracts
- Revision No. 8: Revise Multiple Tracts to show actual lots built and Revise Zoning on other Tracts
- Revision No. 9: Revised SF-2 Parameters, Added PA 16 - Annexation/Zoning
- Revision No. 10: Add Planning Area 17

EXHIBIT D

EXHIBIT A-1