

BLOCK M
STONELAKE ESTATES
PHASE I
(CAB. P. PG. 606)

F.M. NO. 2478 (CUSTER ROAD)

(VARIABLE WIDTH RIGHT-OF-WAY)
(VOL. 2875, PG. 347)

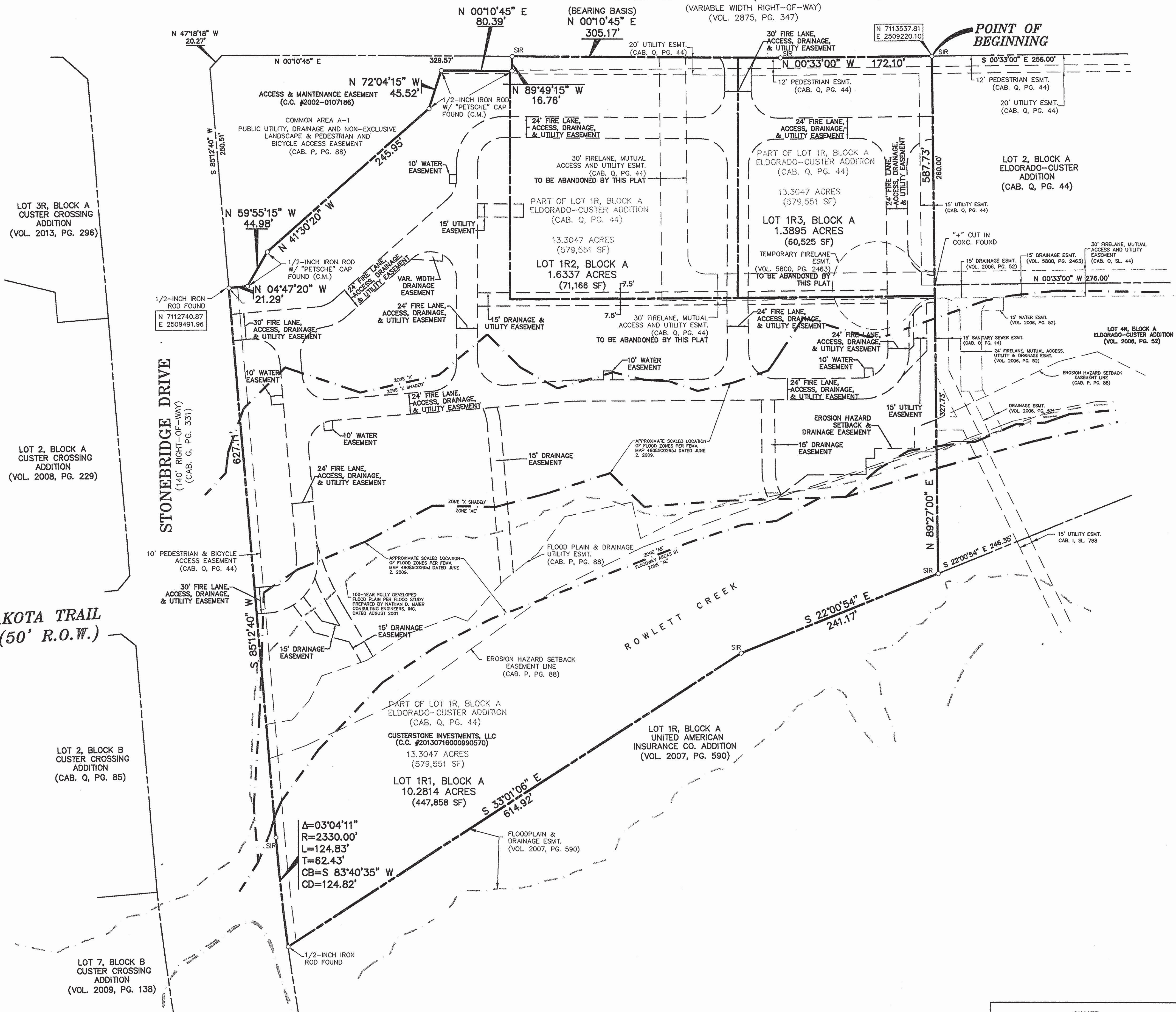
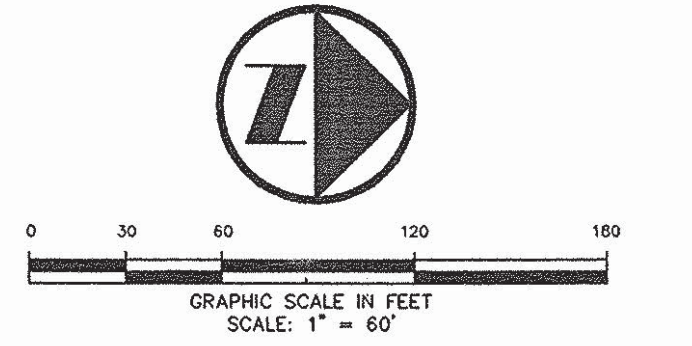
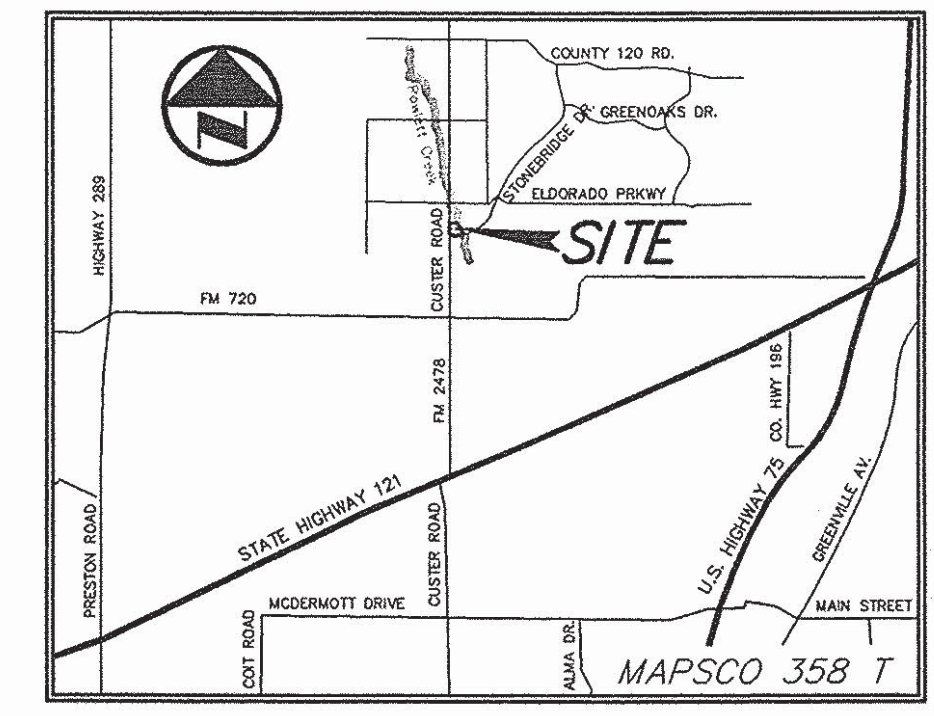

NOTES:

1. BEARING SYSTEM FOR THIS SURVEY IS BASED ON A BEARING OF NORTH 00 DEGREES, 10 MINUTES, 45 SECONDS EAST FOR AN EAST RIGHT-OF-WAY LINE OF CUSTER ROAD, A VARIABLE WIDTH RIGHT-OF-WAY, ACCORDING TO THE PLAT RECORDED IN VOLUME 2875, PAGE 347, OF THE PLAT RECORDS OF COLLIN COUNTY, TEXAS.
2. ALL PROPOSED LOTS SITUATED IN WHOLE OR IN PART WITHIN THE CITY'S CORPORATE LIMITS COMPLY WITH THE MINIMUM SIZE REQUIREMENTS OF THE GOVERNING ZONING DISTRICT.
3. (C.M.) - CONTROLLING MONUMENT

**MINOR REPLAT
ELDORADO-CUSTER ADDITION
LOTS 1R1, 1R2, AND 1R3, BLOCK A
BEING A REPLAT OF LOT 1R, BLOCK A
13.3047 ACRE TRACT**

(CABINET Q, PAGE 44, D.R.C.C.T.)
out of the
J.J. NAUGLE SURVEY, ABSTRACT No. 662
CITY OF MCKINNEY, COLLIN COUNTY, TEXAS

THE PURPOSE OF THIS MINOR REPLAT IS TO DIVIDE LOT 1R INTO THREE LOTS, AND TO DEDICATE EASEMENTS NECESSARY FOR DEVELOPMENT OF THE LOTS.

OWNER
Custerstone Investments, LLC
5068 W Plano Parkway, Suite 121
Plano, TX 75093

PREPARED FOR:
Mr. Lino Andreani
SHB Development, LLC
P.O. Box 175
Shreveport, LA 71161
(318) 423-6111 Phone

POGUE
ENGINEERING & DEVELOPMENT COMPANY, INC.
1512 BRAY CENTRAL DRIVE SUITE 100
MCKINNEY, TEXAS 75069
TX BOARD PROF. ENGINEERS, CERT. # 000481; TX BOARD PROF. LAND SURVEYING, CERT. 100421-00

(214) 544-8880 PHONE
(214) 544-8882 FAX
www.PogueEngineering.com

PREPARED	01-27-2014
SURVEYED	12-18-2014
SCALE:	1"=60'
PI NUMBER	1180-13-071
DRAWN BY:	RLG
CHECKED BY:	RND

MAPS/CAD: 02/07/2014 - 12:45PM
 N:\JOB\1180-13-071-MINOR REPLAT.DWG
 © POGUE ENGINEERING & DEVELOPMENT COMPANY, INC. 2012. ALL RIGHTS RESERVED. THE ENGINEERING DESIGN, DETAIL AND ENGINEERING DRAWINGS FOR THIS PROJECT AND/OR OVERALL PROJECT ARE THE LEGAL PROPERTY OF POGUE ENGINEERING & DEVELOPMENT COMPANY, INC. THEIR USE FOR REPRODUCTION, CONSTRUCTION, OR DISTRIBUTION IS PROHIBITED UNLESS AUTHORIZED IN WRITING BY POGUE ENGINEERING & DEVELOPMENT COMPANY, INC.

WHEREAS, CUSTERSTONE INVESTMENTS, LLC is the owner of a 13.3047 acre tract of land situated in the J.J. Naugle Survey, Abstract No. 662, Collin County, Texas; said tract being all of Lot 1R, Block A, Eldorado-Custer Addition, an addition to the City of McKinney, Texas according to the plat recorded in Cabinet Q, Page 44 of the Plat Records of Collin County, Texas; said 13.3047 acre tract being more particularly described as follows:

BEGINNING, at a 1/2-inch iron rod with "Pogue Eng & Dev" cap set at the northwest corner of said Lot 1R, Block A in the east right-of-way line of F.M. No. 2478 (Custer Road, a variable width right-of-way); said point also being the southwest corner of Lot 2, Block A of said Eldorado-Custer Addition;

THENCE, North 89 degrees, 27 minutes, 00 seconds East, departing the said east line of F.M. No. 2478 and along the common line between said Lot 1R, Block A and said Lot 2, Block A, at a distance of 260.00 feet passing a "4" cut in concrete found at southeast corner of said Lot 2, Block A and the most easterly southwest corner of Lot 4R, Block A, Eldorado-Custer Addition, an addition to the City of McKinney, Texas according to the plat recorded in Volume 2006, Page 52 of the said Plat Records, continuing along the common line between said Lot 1R, Block A and said Lot 4R, Block A, in all a total distance of 587.73 feet to a 1/2-inch iron rod with "Pogue Eng & Dev" cap set for corner; said point also being the most easterly southeast corner of said Lot 4R, Block A;

THENCE, departing the said common line between Lot 1R, Block A and Lot 4R, Block A and along the east line of said Lot 1R, Block A, the following two (2) calls:

South 22 degrees, 00 minutes, 54 seconds East, a distance of 241.17 feet to a 1/2-inch iron rod with "Pogue Eng & Dev" cap set at an angle point;

South 33 degrees, 01 minutes, 06 seconds East, a distance of 614.92 feet to a 1/2-inch iron rod found for corner in the north right-of-way line of Stonebridge Drive (a 140-foot wide right-of-way); said point being the beginning of a non-tangent curve to the right;

THENCE, departing the said east line of said Lot 1R, Block A and along the said north line of Stonebridge Drive and the south line of said Lot 1R, Block A, the following two (2) calls:

In a westerly direction, along said curve to the right, having a central angle of 03 degrees, 04 minutes, 11 seconds, a radius of 2330.00 feet, a chord bearing and distance of South 83 degrees, 40 minutes, 34 seconds West, 124.82 feet, an arc distance of 124.83 feet to a 1/2-inch iron rod with "Pogue Eng & Dev" cap set at the end of said curve;

South 85 degrees, 12 minutes, 40 seconds West, a distance of 627.11 feet to a 1/2-inch iron rod found for corner; said point also being the southeast corner of the Common Area A-1 as shown on the plat recorded in Cabinet P, Page 88 of the said Plat Records;

THENCE, departing the said north line of Stonebridge Drive and said south line of Lot 1R, Block A and along the common line between said Lot 1R, Block A and said Common Area A-1, the following six (6) calls:

North 04 degrees, 47 minutes, 20 seconds West, a distance of 21.29 feet to a 1/2-inch iron rod with "Petsche" cap found for corner;

North 59 degrees, 55 minutes, 15 seconds West, a distance of 44.98 feet to a 1/2-inch iron rod with "Petsche" cap found at an angle point;

North 41 degrees, 30 minutes, 20 seconds West, a distance of 245.95 feet to a 1/2-inch iron rod with "Petsche" cap found at an angle point;

North 72 degrees, 04 minutes, 15 seconds West, a distance of 45.52 feet to a 1/2-inch iron rod with "Petsche" cap found for corner;

North 00 degrees, 10 minutes, 45 seconds East, a distance of 80.39 feet to a 1/2-inch iron rod with "Petsche" cap found for corner;

North 89 degrees, 49 minutes, 15 seconds West, a distance of 16.76 feet to a 1/2-inch iron rod with "Pogue Eng & Dev" cap set for corner in the said east line of F.M. No. 2478; said point also being the northwest corner of said Common Area A-1;

THENCE, departing the said common line between Lot 1R, Block A and Common Area A-1 and along the said east line of F.M. No. 2478 and the west line of said Lot 1R, Block A, the following two (2) calls:

North 00 degrees, 10 minutes, 45 seconds East, a distance of 305.17 feet to a 1/2-inch iron rod with "Pogue Eng & Dev" cap set at an angle point;

North 00 degrees, 33 minutes, 00 seconds West, a distance of 172.10 feet to the POINT OF BEGINNING;

CONTAINING, 579,551 square feet or 13.3047 acres of land, more or less.

SURVEYOR'S CERTIFICATE

KNOW ALL MEN BY THESE PRESENTS:

That I, Roman L. Groysman, do hereby certify that I prepared this plat from an actual survey of the land and that the corner monuments shown hereon were properly placed under my personal supervision in accordance with the Platting Rules and Regulations of the City of McKinney, Collin County, Texas.

PRELIMINARY

RELEASED 01/27/14 FOR REVIEW PURPOSES ONLY. THIS DOCUMENT SHALL NOT BE RECORDED FOR ANY PURPOSE.

Roman L. Groysman,
Registered Professional Land Surveyor
No. 5864



STATE OF TEXAS ~

COUNTY OF COLLIN ~

BEFORE ME, the undersigned authority in and for the State of Texas, on this day personally appeared Roman L. Groysman, known to me to be the person whose name is subscribed to the foregoing instrument and acknowledged to me that he executed the same for the purposes and consideration therein expressed and in the capacity therein stated.

WITNESS MY HAND at Collin County, Texas, this _____ day of _____, 20____

Notary Public in and for the State of Texas.

NOTES:

- BEARING SYSTEM FOR THIS SURVEY IS BASED ON A BEARING OF NORTH 00 DEGREES, 10 MINUTES, 45 SECONDS EAST FOR AN EAST RIGHT-OF-WAY LINE OF CUSTER ROAD, A VARIABLE WIDTH RIGHT-OF-WAY, ACCORDING TO THE PLAT RECORDED IN VOLUME 2875, PAGE 347, OF THE PLAT RECORDS OF COLLIN COUNTY, TEXAS.
- ALL PROPOSED LOTS SITUATED IN WHOLE OR IN PART WITHIN THE CITY'S CORPORATE LIMITS COMPLY WITH THE MINIMUM SIZE REQUIREMENTS OF THE GOVERNING ZONING DISTRICT.
- (C.M.) - CONTROLLING MONUMENT

OWNERS DEDICATION

STATE OF TEXAS ~

COUNTY OF COLLIN ~

NOW, THEREFORE, KNOW ALL MEN BY THESE PRESENTS:

THAT, We, CUSTERSTONE INVESTMENTS, LLC., do hereby adopt this record plat designating the hereinabove described property as the ELDORADO-CUSTER ADDITION, LOTS 1R1, 1R2, AND 1R3, BLOCK A, an addition to the City of McKinney, Collin County, Texas, and do hereby dedicate to the public use forever, their streets, alleys and public use areas shown hereon, the easements, as shown, for mutual use and accommodation of the City of McKinney and all public utilities desiring to use or using same. All and any public utility and the City of McKinney shall have the right to remove and keep removed all or parts of any building, fences, shrubs, trees or other improvements or growths, which in anyway, endanger interfere with the construction, maintenance or efficiency of it's respective systems on said Easements, and the City of McKinney and all public utilities constructing, reconstructing, inspecting, patrolling, maintaining and adding to or removing all or parts of it's respective systems, without the necessity, at anytime, of procuring the permission of anyone.

This plat approved subject to all platting ordinance, rules, regulations and resolutions of the City of McKinney, Texas.

WITNESS MY HAND at MCKINNEY, Texas, this _____ day of _____, 2014.

By: RAVI PEMMASANI
PRESIDENT, CUSTERSTONE INVESTMENTS, LLC

Authorized Signature

STATE OF TEXAS ~

COUNTY OF _____ ~

BEFORE ME, the undersigned authority in and for the State of Texas, on this day personally appeared _____ of _____, authorized representative of _____, authorized to do business in the State of Texas.

GIVEN UNDER MY HAND AND SEAL OF OFFICE this _____ day of _____, 2014.

Notary Public in and for the State of Texas

"Approved and Accepted"

Chairman
Planning & Zoning Commission
City of McKinney, Texas

Date

THE PURPOSE OF THIS MINOR REPLAT IS TO DIVIDE LOT 1R INTO THREE LOTS, AND TO DEDICATE EASEMENTS NECESSARY FOR DEVELOPMENT OF THE LOTS.

OWNER
Custerstone Investments, LLC
5068 W Plano Parkway, Suite 121
Plano, TX 75093

PREPARED FOR:
Mr. Lino Andreani
SHB Development, LLC
P.O. Box 175
Shreveport, LA 71161
(318) 423-6111 Phone

MINOR REPLAT
ELDORADO-CUSTER ADDITION
LOTS 1R1, 1R2, AND 1R3, BLOCK A
BEING A REPLAT OF LOT 1R, BLOCK A
13.3047 ACRE TRACT
(CABINET Q, PAGE 44, D.R.C.C.T.)
out of the
J.J. NAUGLE SURVEY, ABSTRACT No. 662
CITY OF MCKINNEY, COLLIN COUNTY, TEXAS

POGUE
ENGINEERING & DEVELOPMENT COMPANY, INC.
1512 BRAY CENTRAL DRIVE SUITE 100 MCKINNEY, TEXAS 75069 TX BOARD PROF. ENGINEERS, CERT. # 000481; TX BOARD PROF. LAND SURVEYING, CERT. 10421-00
(214) 544-8880 PHONE (214) 544-8882 FAX www.PogueEngineering.com

PREPARED	01-27-2014
SURVEYED	12-18-2014
SCALE:	1"=60'
PI NUMBER	1180-13-071
DRAWN BY:	RLG
CHECKED BY:	RND