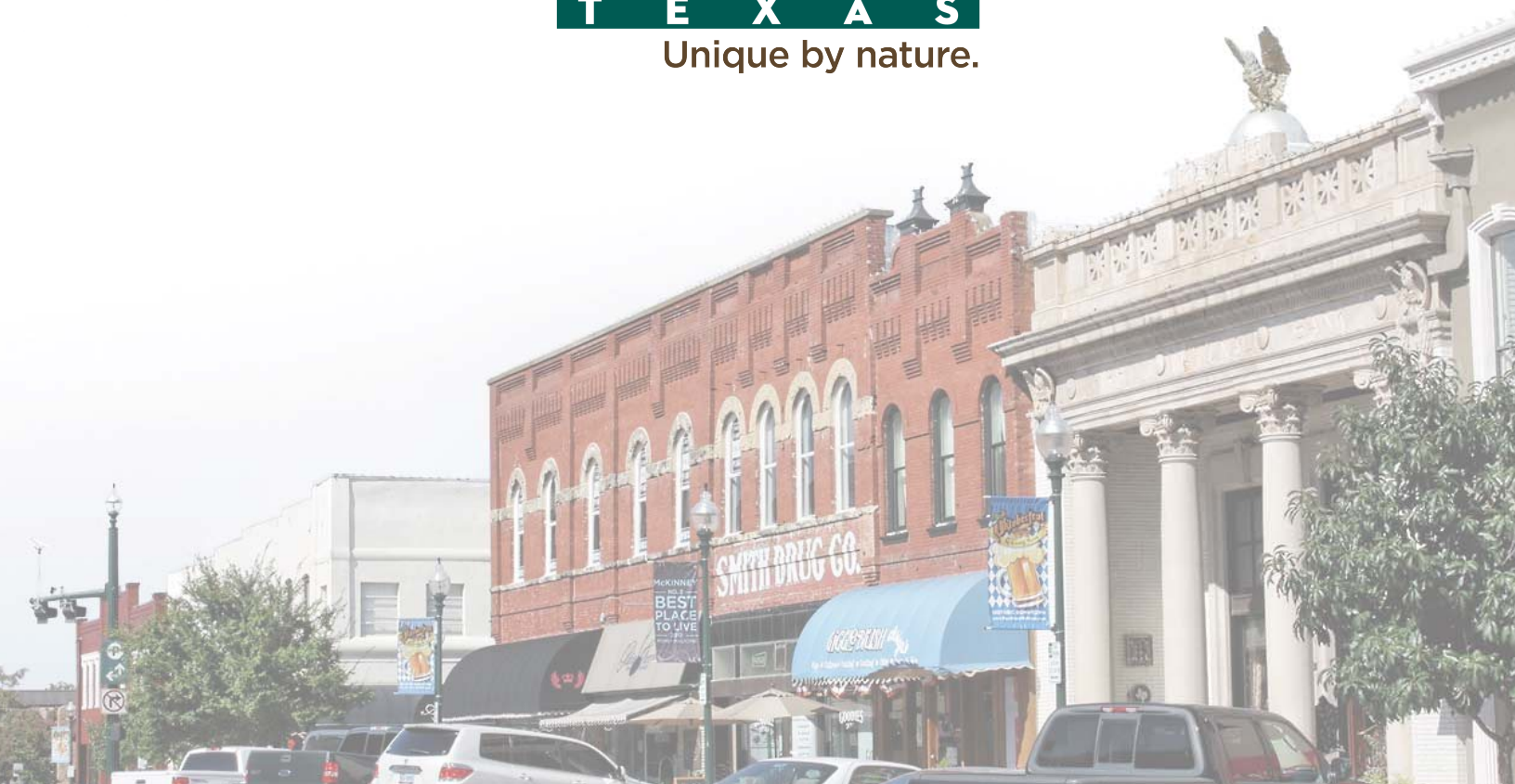




# Engineering Design Manual



City of McKinney Engineering Department  
[www.mckinneytexas.org](http://www.mckinneytexas.org)

Revision 6 Effective Date: November 5, 2024

**CITY COUNCIL**

George Fuller	Mayor
Dr. Geré Feltus	Mayor Pro-Tem – District 3
Justin Beller	Council Member – District 1
Patrick Cloutier	Council Member – District 2
Rick Franklin	Council Member – District 4
Charlie Philips	Council Member At Large 1
Michael Jones	Council Member At Large 2

**CITY MANAGER**

Paul Grimes	City Manager
Kim Flom	Assistant City Manager
Barry Shelton	Assistant City Manager
Steve Tilton	Assistant City Manager

**CITY STAFF**

Michael Quint	Executive Director of Development Services
Ryan Gillingham, P.E.	Director of Public Works
Paul Sparkman & Michael George	Assistant Directors of Public Works
Jennifer Arnold, AICP	Director of Planning
Gary Graham, P.E., PTOE	Director of Engineering
Matt Richardson, P.E.	Assistant Directors of Engineering
Blake Sills, P.E. & Katie McKenzie, P.E.	Engineering CIP Managers
Thuan Huynh, P.E.	Transportation Engineering Manager
Taylor Schauwecker, P.E.	Development Engineering Manager
Kyle Odom, CFM, R.S.	Environmental Manager

**RECORD OF REVISIONS**

The following are the effective date(s) of the City of McKinney Engineering Design Manual and all of its amendments:

Edition Number	Description	Recorded by City Secretary	Effective Date
1-1	Adoption of Engineering Design Manual	3/01/2018	4/04/2018
1-2	Revision 1	6/20/2018	7/20/2018
1-3	Revision 2	8/02/2019	9/01/2019
1-4	Revision 3	12/01/2020	1/01/2021
1-5	Revision 4	2/22/2022	3/24/2022
1-6	Interim Revision 5	7/11/2022	8/11/2022
1-7	Revision 5	10/14/2022	11/15/2022

Edition Number	Description	Adopted by City Council
2-1	Revision 6	11/05/2024

**SECTION 1 GENERAL DESIGN REQUIREMENTS**

1.1.	Title .....	1-1
1.2.	Purpose .....	1-1
1.3.	Interpretation .....	1-1
1.4.	Enforcement .....	1-2
1.5.	Amendment .....	1-3
1.6.	Variance Requests .....	1-3
1.7.	Applicability .....	1-4
1.8.	Accessibility Standards and Requirements .....	1-4
1.9.	Submittal Requirements for Construction Plans .....	1-4
1.10.	Easements .....	1-5
1.11.	Subsurface Utility Engineering .....	1-7
1.12.	Survey Requirements .....	1-7

**SECTION 2 STREET DESIGN REQUIREMENTS**

2.1.	General .....	2-1
2.2.	Street Design .....	2-1
2.3.	Intersections .....	2-17
2.4.	Median Openings .....	2-33
2.5.	Turn Lanes .....	2-35
2.6.	Access Management .....	2-37
2.7.	Driveways .....	2-41
2.8.	Alley Design .....	2-47
2.9.	Traffic Control .....	2-48
2.10.	Pedestrian Facilities .....	2-51
2.11.	Street and Roadway Lighting .....	2-54
2.12.	Conduit Systems .....	2-59
2.13.	Traffic Impact Analysis .....	2-60
2.14.	Gated Access Points .....	2-64

**SECTION 3 PAVEMENT AND SUBGRADE DESIGN REQUIREMENTS**

3.1.	General .....	3-1
3.2.	Existing Surface/Subsurface Investigation .....	3-2
3.3.	Subsurface Design .....	3-4
3.4.	Subgrade Design .....	3-4
3.5.	Pavement Design .....	3-5

**SECTION 4 STORMWATER DESIGN REQUIREMENTS**

4.1.	General .....	4-1
4.2.	Floodplain Development Criteria .....	4-7
4.3.	Design Rainfall .....	4-14
4.4.	Determination of Design Discharge .....	4-17
4.5.	Street Flow .....	4-23
4.6.	Inlet Design .....	4-27
4.7.	Storm Drain Design .....	4-36
4.8.	Open Channels .....	4-53

4.9.	Bridge and Culvert Hydraulic Design .....	4-59
4.10.	Detention Basin Design .....	4-62
4.11.	Site Erosion Control.....	4-72
4.12.	Dam and Impoundment Design .....	4-72

**SECTION 5 WATER AND WASTEWATER DESIGN REQUIREMENTS**

5.1.	General .....	5-1
5.2.	Water System Design Criteria .....	5-8
	A. General.....	5-8
	B. Water Services .....	5-8
	C. Water Demand and Supply .....	5-9
	D. Pressure Planes .....	5-10
	E. Sizing Water Distribution Mains .....	5-10
	F. Horizontal Alignment and Vertical Alignment .....	5-13
	G. Depth of Cover .....	5-14
	H. Pipe Material.....	5-14
	I. Fittings.....	5-17
	J. Pipe Embedment .....	5-17
	K. Dead-End Mains .....	5-17
	L. Fire Hydrants .....	5-17
	M. Valves.....	5-20
	N. Connections to Existing Water Mains.....	5-22
	O. Abandonment of Wastewater Mains .....	5-23
	P. Flushing and Disinfection.....	5-24
5.3.	Wastewater Design Criteria .....	5-27
	A. General.....	5-27
	B. Sewer Services.....	5-27
	C. Design Flow .....	5-28
	D. Sizing Wastewater Collection Mains .....	5-29
	E. Inflow and Infiltration.....	5-31
	F. Horizontal Alignment and Vertical Alignment .....	5-32
	G. Depth of Cover .....	5-34
	H. Manhole Locations and Manhole Sizes.....	5-34
	I. Pipe Material.....	5-37
	J. Pipe Embedment .....	5-39
	K. Cleanouts .....	5-39
	L. Connections to Existing Wastewater Mains .....	5-40
	M. Abandonment of Wastewater Lines .....	5-40
5.4.	Wastewater Lift Station Design Criteria .....	5-41
	A. General.....	5-41
	B. Site Selection and Requirements.....	5-41
	C. Wet Well and Valve Vault Design .....	5-43
	D. Pumps, Lift Station Piping, and Valves .....	5-46
	E. Force Main .....	5-48
	F. Electrical Requirements for New Lift Stations .....	5-50
	G. Emergency Provisions for Lift Stations.....	5-53
5.5.	Water and Wastewater Treatment Plant Design Criteria.....	5-53



**SECTION 6 STRUCTURAL DESIGN REQUIREMENTS**

6.1.	General .....	6-1
6.2.	Code Requirements.....	6-2
6.3.	Excavation Support .....	6-3
6.4.	Geotechnical Performance Specifications .....	6-3
6.5.	Bridge Design.....	6-5
6.6.	Retaining Wall Design .....	6-7
6.7.	Slope Stability Design Criteria .....	6-9
6.8.	Screening Wall Design Criteria.....	6-9
6.9.	Headwalls and Wingwalls.....	6-10
6.10.	Culverts.....	6-10
6.11.	Drop Structures .....	6-10
6.12.	Aerial Crossings .....	6-10
6.13.	Non-Bridge Construction Inspection and Certification.....	6-11
6.14.	Bridge Construction Inspection and Certification .....	6-11

**SECTION 7 LANDSCAPE AND IRRIGATION DESIGN REQUIREMENTS**

7.1.	General .....	7-1
7.2.	Landscape Requirements within Right-of-Way .....	7-2
7.3.	Irrigation Design Requirements within Right-of-Way.....	7-4
7.4.	Street Trees.....	7-4

**SECTION 8 ENVIRONMENTAL DESIGN REQUIREMENTS**

8.1.	General .....	8-1
8.2.	Texas Construction General Permit and City Requirements.....	8-2
8.3.	Stormwater Pollution Prevention Plan – Temporary Controls .....	8-3
8.4.	Post Construction Stormwater Quality Plan – Permanent Controls.....	8-6

**LIST OF TABLES**

<b>Table 2-1</b>	General Roadway Design Criteria.....	2-3
<b>Table 2-2</b>	Intersection Sight Distance .....	2-24
<b>Table 2-3</b>	Corner Clip Distance.....	2-26
<b>Table 2-4</b>	Inscribed Circle Diameter.....	2-29
<b>Table 2-5</b>	Minimum Turn Lane Design Requirements .....	2-35
<b>Table 2-6</b>	Minimum Driveway Throat Length for Number of Exit Lanes.....	2-43
<b>Table 2-7</b>	Commercial and Industrial Driveway Spacing .....	2-45
<b>Table 2-8</b>	Maximum Driveway Grade Change .....	2-46
<b>Table 2-9</b>	Vertical Curve Length for Driveways .....	2-46
<b>Table 2-10</b>	Photometric Design Criteria .....	2-57
<b>Table 2-11</b>	Mounting Height Restrictions .....	2-58
<b>Table 3-1</b>	Pavement and Subgrade Minimum Standards.....	3-1
<b>Table 3-2</b>	Pavement Design Input Values.....	3-6

<b>Table 4-1</b>	Collin County Rainfall Intensity Data .....	4-15
<b>Table 4-2</b>	24-Hour Rainfall Depths.....	4-16
<b>Table 4-3</b>	Design Frequency and Freeboard Requirements.....	4-17
<b>Table 4-4</b>	Frequency Factors.....	4-19
<b>Table 4-5</b>	Runoff Coefficients and Minimum Inlet Time Guidelines .....	4-20
<b>Table 4-6</b>	Sheet Flow Roughness Coefficients .....	4-22
<b>Table 4-7</b>	Water Spread Limits for Roadways.....	4-23
<b>Table 4-8</b>	Allowable Intersection Flows.....	4-25
<b>Table 4-9</b>	Grate Effective Area.....	4-32
<b>Table 4-10</b>	Storm Drain Roughness Coefficients .....	4-38
<b>Table 4-11</b>	Maximum Spacing of Manholes and Junction Boxes .....	4-38
<b>Table 4-12</b>	Maximum Storm Drain Flow Velocity .....	4-40
<b>Table 4-13</b>	Frequencies for Coincidental Occurrences .....	4-41
<b>Table 4-14</b>	Head Loss Coefficients .....	4-45
<b>Table 4-15</b>	Typical Values for $K_c$ - Sudden Pipe Contraction in Non-Pressure Flow.....	4-49
<b>Table 4-16</b>	Typical Values for $K_e$ - Gradual Pipe Enlargement in Non-Pressure Flow .....	4-49
<b>Table 4-17</b>	Typical Values for $K_e$ - Gradual Pipe Enlargement in Pressure Flow.....	4-50
<b>Table 4-18</b>	Typical Values for $K_c$ - Sudden Pipe Contractions in Pressure Flow .....	4-50
<b>Table 4-19</b>	Typical Values for $K_e$ - Sudden Pipe Enlargement in Pressure Flow .....	4-51
<b>Table 4-20</b>	Roughness Coefficients and Allowable Velocities for Channels .....	4-55
<b>Table 4-21</b>	Culvert Entrance Loss Coefficients .....	4-61
<b>Table 5-1</b>	Residential Water Demand by Land Use .....	5-11
<b>Table 5-2</b>	Non-Residential Water Demand by Land Use .....	5-11
<b>Table 5-3</b>	Standard Water Main Sizes .....	5-13
<b>Table 5-4</b>	Depth of Cover to Top of Pipe.....	5-14
<b>Table 5-5</b>	Pipe Materials for Mains .....	5-16
<b>Table 5-6</b>	Standard Wastewater Main Sizes .....	5-29
<b>Table 5-7</b>	Residential Wastewater Flows by Land Use .....	5-30
<b>Table 5-8</b>	Non-Residential Wastewater Flows by Land Use.....	5-31
<b>Table 5-9</b>	Grades for Wastewater Mains.....	5-33
<b>Table 5-10</b>	Manhole Diameter Requirements.....	5-36
<b>Table 5-11</b>	Pipe Materials for Gravity Mains .....	5-38
<b>Table 5-12</b>	Minimum Pump Cycle Time .....	5-45
<b>Table 5-13</b>	Materials for Force Mains .....	5-49
<b>Table 7-1</b>	Canopy Trees Approved Within Medians and Parkways.....	7-3
<b>Table 7-2</b>	Ornamental Trees Approved Within Medians and Parkways.....	7-3
<b>Table 7-3</b>	Median Landscaping Requirements.....	7-4
<b>Table 7-4</b>	Street Tree Separation Requirements.....	7-6
<b>Table 8-1</b>	Minimum Number of Permanent BMPs Required.....	8-6
<b>Table 8-2</b>	Structural Control Screening Matrix (iSWM Technical Manual-Site Development Controls, April 2010, Rev9/2014) .....	8-12

**LIST OF FIGURES**

<b>Figure 2-1A</b>	Major Arterial Roadway Typical Sections.....	2-4
<b>Figure 2-1B</b>	Minor Arterial Roadway Typical Sections.....	2-6
<b>Figure 2-1C</b>	Collector Roadway Typical Sections.....	2-8
<b>Figure 2-1D</b>	Residential Roadway Typical Sections .....	2-9
<b>Figure 2-2</b>	Horizontal Sight Distance Diagram.....	2-11
<b>Figure 2-3</b>	Cross-Over Design.....	2-14
<b>Figure 2-4</b>	Intersection Layouts .....	2-19
<b>Figure 2-5</b>	Offset Intersections .....	2-23
<b>Figure 2-6</b>	Horizontal Intersection Visibility Triangles .....	2-24
<b>Figure 2-7</b>	Vertical Intersection Visibility Easements .....	2-24
<b>Figure 2-8</b>	Corner Clips for an Intersection .....	2-26
<b>Figure 2-9</b>	Typical Roundabout .....	2-28
<b>Figure 2-10</b>	Vehicle Path Radii.....	2-31
<b>Figure 2-11</b>	One-Way Left Turn Lane Detail.....	2-34
<b>Figure 2-12</b>	Intersection Design Diagram .....	2-35
<b>Figure 2-13</b>	Insufficient Driveway Throat Length .....	2-43
<b>Figure 2-14</b>	Capacity Limited by Throat Length and Weaving Area .....	2-44
<b>Figure 2-15</b>	Driveway Spacing on Opposite Sides of an Undivided Street.....	2-45
<b>Figure 2-16</b>	Typical Alley Layout .....	2-48
<b>Figure 2-17</b>	Typical Residential Street Lighting System Layout .....	2-56
<b>Figure 4-1</b>	Natural Channels: Erosion Hazard Setback, Floodplain, and Drainage Easements	4-5
<b>Figure 4-2</b>	Floodplain Development Flow Chart.....	4-8
<b>Figure 4-3</b>	Maximum Water Spread Limits.....	4-24
<b>Figure 4-4</b>	Maximum Water Spread Limits for Alleys .....	4-26
<b>Figure 4-5</b>	Types of Inlets.....	4-29
<b>Figure 4-6</b>	Curb Inlet in a Sump Diagram .....	4-33
<b>Figure 4-7</b>	Gutter Cross Section Diagram.....	4-36
<b>Figure 4-8</b>	Junction Losses Without a Manhole or Junction Box.....	4-46
<b>Figure 4-9</b>	Junction Losses with a Manhole or Junction Box .....	4-47
<b>Figure 4-10</b>	Angle of Concentration for Pipe Diameter Changes .....	4-51
<b>Figure 4-11</b>	Inlet Losses.....	4-52
<b>Figure 4-12</b>	Alternate Depths on the Specific Energy Curve .....	4-56
<b>Figure 4-13</b>	Modified Rational Method Detention Pond Design Relationship of Inflow, Outflow, and Storage Requirements .....	4-69
<b>Figure 4-14</b>	Computation Sheet for Modified Rational Method Detention Pond Design ...	4-70
<b>Figure 4-15</b>	Example Computation Sheet for Modified Rational Method Detention Pond Design.....	4-71
<b>Figure 7-1</b>	Street Tree Typical Sections .....	7-5



**APPENDIX A – DEFINITIONS AND ABBREVIATIONS**

**APPENDIX B – CITY CHECKLISTS**

**CITY CHECKLIST**

Geotechnical Report for Roadways Checklist

Summary of Geotechnical Recommendations Form

Bridge Construction Inspection and Certification Checklist

Post Construction Stormwater Quality Plan Checklist

Land Acquisition Submittal Checklist

[Civil Engineering Plan Submittal Process](#)

[Civil Engineering Development Plan Review Checklist](#)

[Tree Permit Requirements Checklist](#)

[Engineering Development Final Acceptance Checklist](#)

## SECTION 1 GENERAL DESIGN REQUIREMENTS

### 1.1. Title

These standards are hereby adopted as the “Engineering Design Manual,” Sections 1 – 8 and Appendices, which shall be in full force and effect from and after the effective date of adoption of the Engineering Design Manual.

### 1.2. Purpose

The purpose of the Engineering Design Manual is to protect the health, safety, and welfare of the public by establishing standard engineering practices and minimum engineering criteria for the City of McKinney (City), Texas, and its extraterritorial jurisdiction (ETJ).

### 1.3. Interpretation

- 1.3.A. In the interpretation and application of the provisions of these regulations, it is the intention of the City that the principles, standards, and requirements provided for herein shall be minimum requirements for the design of both public and municipal capital projects in the City and its ETJ. The Engineer of Record (Engineer) is expected to meet all City, State, and Federal ordinances and regulations set by the right-of-way or easement owner. The Engineering Design Manual contains City-specific criteria. Where other City, State, Federal, or other jurisdiction regulations are more restrictive than the Engineering Design Manual, such other ordinances or regulations shall govern.
- 1.3.B. The City has adopted various ordinances, master plans, policies, and documents, which address requirements not explicitly included in the Engineering Design Manual, including, but not limited to, the following below. The Engineer is responsible for requesting additional City requirements, such as corridor-specific or Planned Development (PD) master plans, that may not be included in this list. The Engineer is responsible for understanding and complying with the [City's various ordinances and master plans](#).
1. [Comprehensive Plan](#)
  2. Construction Standards and Specifications Manual\* including: Technical Specifications, General Notes, Standard Details, and Approved Materials Lists.  
*\*Development in progress. Current construction standards, details, and specifications shall be used until the new manual is adopted.*
  3. [iSWM Technical Manuals](#)
  4. [NCTCOG Standards and Specifications for Public Works Construction](#)
  5. [Stream Bank Stabilization Manual](#)
  6. [Floodplain Management Study for Wilson Creek, Franklin Branch, Stover Creek and Honey Creek](#)

7. [TPDES Phase II Stormwater Management Program](#)
8. [Right-of-Way Construction and Permitting Procedures Manual](#)
9. [Neighborhood Traffic Management Program](#)
10. [Addressing Standards \(GIS\)](#)
11. [Roadway Capital Improvement Plan and Impact Fee Update](#)
12. [Water and Wastewater Capital Improvement Plan and Impact Fee Update](#)
13. Master Plans
  - a. Water Distribution System Master Plan (*Request from Engineering*)
  - b. Wastewater Collection System Master Plan (*Request from Engineering*)
  - c. [Master Thoroughfare Plan](#)
  - d. [McKinney Town Center Phase 1: Report and Illustrative Plan](#)
  - e. [Historic Downtown Parking and Wayfinding Studies](#)
  - f. [Northwest Sector Study Phase 1 Report](#)
  - g. [S.H. 5 Corridor Master Plan](#)
  - h. [Public Art Master Plan](#)
  - i. [Parks, Recreation, Open Space, Trails, and Streetscape Visioning Master Plan](#)
14. Code of Ordinances or as Amended
  - a. [Building Codes Ordinance \(Ch. 122 Art. II\)](#)
  - b. [Water and Wastewater Impact Fees Ordinance \(Ch. 130 Art. II Div. 1\)](#)
  - c. [Roadway Impact Fees Ordinance \(Ch. 130 Art. III Div. I\)](#)
15. [Unified Development Code or as Amended](#)
16. [International Fire Code as adopted by the City](#)

#### **1.4. Enforcement**

1.4.A. The City's Engineering Design Manual is issued by the Engineering Department. The Engineering Department is hereby authorized to enforce the provisions of the Engineering Design Manual. The standards and any updates will be available on the [City's website](#).

1.4.B. The Engineering Design Manual shall be in full force and effect immediately upon being filed with the City Secretary. Projects will be required to comply with all requirements. The Engineering Design Manual includes the various design criteria which are considered minimum requirements for the design of adequate public facilities within the City. The Engineer shall bear the sole responsibility for meeting the Engineering Standard of Care for all aspects of the design and providing a design that is required by the site-specific conditions and intended use of the facilities, while at a minimum meeting the City's design and construction requirements.

## **1.5. Amendment**

1.5.A. The City may amend the Engineering Design Manual at any time without advanced notice. In order to ensure that the Engineer has the City's latest design standards, he/she is directed to the City's website to acquire the City's most current Engineering Design Manual. The Engineering Design Manual will include a Record of Revisions to identify any revisions.

1.5.B. A formal request to modify current design criteria or add new design criteria may be submitted in writing to the Director of Engineering for consideration.

## **1.6. Variance Requests**

1.6.A. A formal request to vary from the Engineering Design Manual may be submitted in writing to the Director of Engineering for consideration. An Engineer who wishes to request a variance regarding the design of public facilities may do so as long as the request, if granted:

1. Is not detrimental to the public welfare;
2. Does not adversely impact the public facility in question;
3. Is supported by a signed and sealed engineering analysis performed by a Professional Engineer licensed in the State of Texas; and,
4. Is not based solely on financial interests.

1.6.B. All deviations from the requirements included in the Engineering Design Manual must be approved by the Director of Engineering prior to implementation. A grant of an alternative material, design, or method of construction shall not affect nor relieve the Engineer of the obligation and responsibility of such material, design, or method of construction for the intended purposes.

1.6.C. In the event that specific circumstances dictate requirements not already included in the Engineering Design Manual, it shall be the responsibility of the Engineer to provide the additional information in writing for review as deemed necessary by the Director of Engineering.

## **1.7. Applicability**

The Engineer shall be responsible for the applicability of the information contained in the Engineering Design Manual to the design of his/her project. The Engineer shall also be responsible for the applicability and accuracy of the information furnished in his/her design. Acceptance by the City of the study or plans for construction shall not be construed to relieve the Engineer of any responsibility.

## **1.8. Accessibility Standards and Requirements**

All plans and specifications for construction shall be in accordance with Texas Accessibility Standards (TAS), Americans with Disabilities Act (ADA), and Proposed Accessibility Guidelines for Pedestrian Facilities in the Public Right-of-Way (PROWAG) regulations. In the event that the accessibility standards conflict with each other, the more restrictive standards shall govern.

## **1.9. Submittal Requirements for Construction Plans**

- 1.9.A. All new construction, reconstruction, modifications, alterations, and improvements shall be designed in accordance with the City's Engineering Design Manual.
- 1.9.B. Section 212.009 of the Texas Local Government Code specifies that construction plans are approved by the City unless they are disapproved within 30 days after the plan is filed. All plans filed with the City of McKinney for review shall be sealed by the design engineer as they may be approved for construction as a result of inaction by the City of McKinney. The term "filed" shall be as defined by Section 142-9 of the City of McKinney Code of Ordinances.
- 1.9.C. Specific submittal requirements for construction plans can be found within the Civil Engineering Plan Review Development Checklist. It is the responsibility of the Engineer to ensure that all construction plans submitted for review adhere to the current version of the [Civil Engineering Plan Review Development Checklist](#). The City reserves the right to specify additional requirements as necessary to facilitate the review.
- 1.9.D. Plan-specific notes detailing standard construction requirements shall be included on construction plans as determined by the Director of Engineering.
- 1.9.E. Any projects requiring permits from agencies other than the City (including, but not limited to, TxDOT, NTTA, or Railroad Commissions) shall submit the required permit documents to the City for initial review. Authorization to submit permit requests to the agencies is contingent upon the City's approval of the initial review. The City may elect to lead coordination and/or submittal of permit requests to the agencies.
- 1.9.F. A listing of required fees for City review of construction plans is available on the [City's website](#).
- 1.9.G. If, as the result of a development submittal or action, the City is required to make a payment to another public or private agency, such payment shall be assigned to the



Applicant. Payment may be made directly by the Applicant to the other agency or may be made by the Applicant to the City and then passed through the City.

### **1.10. Easements**

1.10.A. General – Easements and ROW required for construction of a proposed project and dedicated to the public or to the City must be approved and accepted prior to the approval of final design drawings. All on-site easements required for the purposes of development must be dedicated by plat unless otherwise approved by the Director of Engineering.

1.10.B. Requirements for Easements and ROW dedicated to the City:

1. Easements and ROW shall be either a part of the dedication on the plat of a subdivision or dedicated by separate instrument.
2. Easements and ROW not dedicated on a plat shall be dedicated to the City on standard forms provided by the City for that purpose or on forms approved by the City Attorney. Approved document forms and instructions can be found on the [City's website](#).
3. Owner shall also furnish the City with a metes and bounds description and map, signed and sealed by a Texas Registered Professional Land Surveyor, showing the Easement or ROW, location and current ownership information.
4. All Easement and Deed documents must be approved by the City prior to procuring any signatures. Owner shall be responsible for procuring signatures and delivering the fully executed original document to the City for filing. Owner shall ensure that all documents have been properly signed and any required notarizations have occurred.
5. Owner shall be responsible for all filing fees required for the recordation of executed documents at the Collin County Deed Records office. Owner shall provide the City with a check made out to the Collin County Clerk for the amount of the calculated filing fees.
6. After recordation, a copy of the filed document will be forwarded to the Owner.

1.10.C. The process for acquiring an easement by separate instrument is as follows:

1. Submit a metes and bounds description, a drawing of the easement sealed, signed and dated by a licensed surveyor, and ownership information to the Engineering Department.
2. Prepare the easement documents based on the City's [template documents](#).
3. After fee is paid to City, the easement documents will be sent to the individual or entity requesting the easement to obtain all necessary signatures (other than City's).

4. The individual or entity requesting the easement shall pay any document preparation and filing fees required by the City.
  5. The individual or entity shall return all signed documents to the City for filing with the County.
  6. City will send a copy of the filed easement to the person requesting the easement and the easement grantor, if needed.
- 1.10.D. Abandonment of ROW and Easements – ROW abandonment requires City Council approval. Refer to the City's [Right-of-Way Vacation and Alley Abandonment Requirements & Checklists](#) for additional information.
- 1.10.E. License Agreements – The City may allow permitting of certain improvements within easements with the execution of an License Agreement, which is in addition to a building permit. The agreement states that the City is not responsible for the maintenance or reconstruction of any improvements located in the easement or ROW and that the Owner must remove the improvement at the request of the City. Forms and instructions are available from the Engineering Department.
- 1.10.F. License Agreements are processed by the Engineering Department. The following items shall require a License Agreement:
1. Driveways/flatwork;
  2. Brick or stone fences;
  3. Retaining walls (less than 15 inches in height that support a structure or greater than 15 inches, see **Section 6.1.C**);
  4. Private storm systems/area drains;
  5. Swimming pools decks;
  6. Wood decks, gazebos, and patios (covered/uncovered);
  7. Sidewalk areas leased for development use; and,
  8. Buildings and other permanent improvements.
- 1.10.G. No improvements shall be allowed within a public easement except for those specified by a filed plat or separate instrument easement. The Director of Engineering may approve simple paving, utility crossings, landscaping, and other improvements that do not unreasonably impede access to the easement via the approval of a Development Permit. The Director of Engineering may approve other more significant encroachments with the execution of a License Agreement.
- 1.10.H. Slopes in public easements shall not exceed 4:1 running slope and 6:1 cross slope for maintenance access, except as stated otherwise by this manual. Easements located within natural areas shall not be required to comply with this paragraph except that access routes shall be provided periodically in accordance with Section

4.8 "Open Channels". The Director of Engineering may determine the need for additional access routes and/or lesser slopes at locations of critical infrastructure.

### **1.11. Subsurface Utility Engineering**

- 1.11.A. Subsurface Utility Engineering (SUE) shall be required for all projects. All existing utilities shall be located and marked prior to initiation of survey for design.
- 1.11.B. SUE Provider Requirements – SUE shall be conducted by well-trained, experienced, and capable individuals using state-of-the-art designating equipment, vacuum excavation, or comparable nondestructive locating equipment as well as surveying, data recording equipment, and software systems, as necessary.
- 1.11.C. Quality Level Attributes – Utility Quality Level (QL) attributes are described in the current edition of *Standard Guidelines for Collection and Depiction of Existing Subsurface Utility Data, CI/ASCE 38-02* by American Society of Civil Engineers (ASCE). Accordingly, QL C and QL D shall be conducted for all projects. QL A and QL B shall be conducted in areas with congested utilities, areas where utility information is sparse, where a specific utility of high importance is being crossed (i.e., gas line), or as required by the Director of Engineering. QL A and B shall be conducted for all projects if borings will be taken or if an open cut is needed to install utilities. The requirements for the four SUE QLs are as follows:
1. Quality Level D – Information derived from existing records or oral recollections.
  2. Quality Level C – Information obtained by surveying and plotting visible above-ground utility features and by using professional judgment in correlating this information to Quality Level D.
  3. Quality Level B – Information obtained through the application of appropriate surface geophysical methods to determine the existence and approximate horizontal position of subsurface utilities. This work shall be performed to obtain horizontal location of subsurface utilities.
  4. Quality Level A – Precise horizontal and vertical location of utilities obtained by the actual exposure and subsequent measurement of subsurface utilities, usually at a specific point. This work shall be performed to obtain precise horizontal and vertical locations of subsurface utilities.
- 1.11.D. Additional SUE field work shall be required as conditions change from initial SUE field exploration.

### **1.12. Survey Requirements**

- 1.12.A. The principals, standards, and requirements provided herein shall be minimum standards for projects involving survey. All survey shall be tied to the [City of McKinney Control Monuments](#).

- 1.12.B. Markers – Markers consisting of minimum 3/8 inch diameter steel rods at least 24 inches long with caps identifying responsible surveying firm or RPLS number shall be placed at all:
1. Lot and block corners (wherever a lot line bearing changes);
  2. Intersection points of alley and block lines;
  3. Curve and tangent points along block, lot, and ROW lines within the subdivision; and,
  4. ROW dedications.
- 1.12.C. Monuments – Monuments shall be installed and three-dimensional coordinates noted on the Plat. Coordinates shall be established using the scale factor.
- 1.12.D. Subdivision Monumentation – At least two Markers shall be placed at property corners in addition to at least two Monuments at opposing ends of the property.
- 1.12.E. Capital Improvements Project Monuments – Found existing ROW monuments, survey markers, or property corners, and proposed monuments shall be shown on the construction drawings and located by station and offset, right or left from the control line, base line or center line, or by northing and easting.
- 1.12.F. If new construction will damage, destroy, or alter existing survey markers, monuments, or property corners, they must be re-set prior to final acceptance.
- 1.12.G. Electronic Submittal Requirements – The City requires the submittal of CAD files for all plats within the City of McKinney. The Engineer must provide Grid Coordinates (State Plane) or Surface Coordinates with the scale factor. The electronic files shall include the following:
1. Two Monuments (with three-dimensional coordinates);
  2. Markers at a minimum of two property corners (with three-dimensional coordinates);
  3. Parcel boundaries; and,
  4. ROW and easement dedications.
- 1.12.H. Plat Acceptance
1. Prior to Record Plat Acceptance, all required Monuments must be found and re-set if damaged during construction.
    - a. The surveyor shall provide two Monuments acceptable to the City and establish grid coordinates for the monuments in reference to the City of McKinney GPS Monuments.

- b. Elevations will be established on the two monuments on the vertical datum in reference to the City of McKinney GPS Monuments.
- c. The three-dimensional coordinates in grid coordinates established for these monuments will be clearly shown on the face of the plat. A note shall be added to the plat specifying the grid coordinates are not for design purposes.
- d. The plat shall hold grid bearings and shall not be from an assumed north.
- e. All distances shown on the plat will be surface distances.
- f. To ensure that all necessary easements are reflected on the Record Plat, a preliminary inspection should be completed after all construction work has been completed and before the Record Plat is submitted for approval.



## SECTION 2 STREET DESIGN REQUIREMENTS

### 2.1. General

This section presents the basic criteria to be used in the design of roadways in the City of McKinney. The design controls described in this section should be used in the design of all roadways and shall be in conformity with the City's Comprehensive Plan. Any variance required due to project specific constraints must be approved by the Director of Engineering. At a minimum, all thoroughfare designs shall meet the guidelines in AASHTO's current edition of *A Policy on Geometric Design of Highways and Streets*.

### 2.2. Street Design

#### 2.2.A. Functional Classification

1. The City recognizes the following basic classifications of public roadways that include highways, major thoroughfares, minor thoroughfares, collectors, and local streets as identified in the Comprehensive Plan. Each class provides a certain degree of continuity, capacity, and accessibility to adjacent land uses. While differentiated by function, there is also a variance in geometric design. **Table 2-1** summarizes the general design criteria of roadways within the City. The typical cross sections are depicted in **Figure 2-1**. Designer may vary from these requirements as part of the approval of Planned Developments. The roadway classifications and their respective roadway types are as follows:
  - a. Principal Arterial (P6D)
  - b. Major Arterial (M6D)
  - c. Greenway Arterial (G6D/G4D)
  - d. Minor Arterial (M4D/M4U/M3U/M3U-F)
  - e. Commercial/Residential Collectors (C2U)\*
  - f. Residential Streets (R2U)\*
  - g. Residential Alleys (RA)
  - h. Town Thoroughfare and Urban Streets – Transportation facilities which serve established communities and/or those which serve an urban mixed use development must take a context sensitive approach through the planning and design process. Context Sensitive Solutions is a philosophy where planners and designers initially determine what is important to the surrounding community and future use of the facility as well as what is important to preserve and enhance to complement the natural environment. That information is then utilized to design streets, sidewalks, trails, drainage facilities, streetscapes, parking, and other amenities to address the

transportation and mobility needs in a way that is in harmony with the surrounding development context.

\*Additional roadway classifications are provided in the Northwest Sector Study. Additional typical sections may be considered based on a context sensitive approach. Where Street Trees are proposed in accordance with **Section 7.4** of this manual, the typical roadway sections noted in that section shall be used.

2. Acronyms – P = Principal; M = Major/Minor; G = Greenway; C = Collector; R = Residential; A = Alley; D = Divided; U = Undivided; and, F = Frontage Roadway.

Table 2-1 – General Roadway Design Criteria

Criteria	Roadway Classification										
	Major Arterial				Minor Arterial				Collector	Residential	
	P6D	M6D	G6D	G4D	M4D	M4U	M3U	M3U-F	C2U	R2U	RA
ROW Width	130'	124'	140'	120'	100'	80'	68'	70'	50-60'	50'	17'-20'
Number of Lanes	6	6	6	4	4	4	3	3	2	2	1
Paving Width	2-36' f-f	2-36' f-f	2-33' f-f	2-22' f-f	2-22' f-f	44' f-f	36' f-f	40' f-f	26-36' f-f	26' f-f	12'-15'
Thru Lane Width	12'	12'	11'	11'	11'	11'	11'	12'	-	-	12'-15'
Left Turn Lane Width	11'	11'	11'	11'	11'	11'	11'	11'-	11'	-	-
Right Turn Lane Width	11'	11'	11'	11'	11'	11'	11'	11'	11'	-	-
Median Width	20' f-f	20' f-f	36' f-f	20' f-f****	20' f-f	-	-	-	-	-	-
Parkway Width	19'	16'	19'	20'	18'	18'	16'	15'	12'	12'	2.5'
Sidewalk Width***	8'	8'	8'	10'	8'	8'	6'	6'	5' / 6'	5'	-
Design Speed	45 mph	40 mph	40 mph	40 mph	40 mph	35 mph	35 mph	45 mph	30 mph	30 mph	15 mph
Minimum Horizontal Centerline Radius	1,100'	825'	825'	825'	800'	550'	550'	1,050'	350'	350'	250'
Minimum Tangent Between Curves	200'	200'	200'	200'	200'	200'	200'	200'	100'	100'	-
Maximum Grade	6.0%	6.0%	6.0%	6.0%	6.0%	6.0%	6.0%	6.0%	6.0%	6.0%	6.0%
Minimum Grade*	0.5%	0.5%	0.5%	0.5%	0.5%	0.5%	0.5%	0.5 %	0.5%	0.5%	0.5%
Minimum Vertical Crest Curve (K)	61	44	44	44	44	29	29	61	19	19	-
Minimum Vertical Sag Curve (K)	79	64	64	64	64	49	49	79	37	37	-
Design Vehicle	WB-67 Truck/Trailer								Fire Truck		
Parking	Prohibited	Prohibited	Prohibited	Prohibited	Prohibited	Prohibited	Prohibited	Prohibited	Allowed	Allowed	Allowed
Volume Range (VPD)	39,000-42,000	35,000-38,000	35,000-38,000	26,000-31,000	26,000-31,000	17,000-20,000	21,000-24,000	19,500-21,000	**	1,000-1,400	-

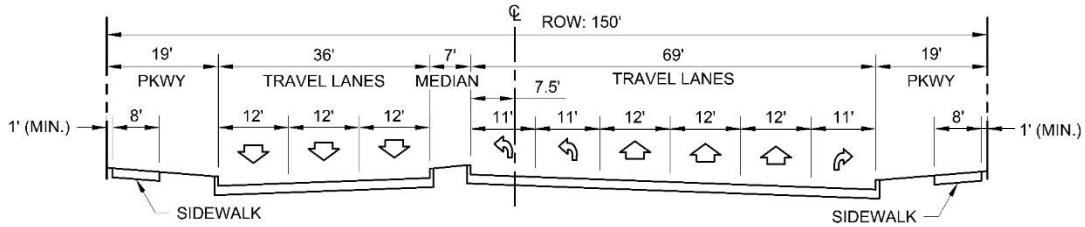
\*Minimum Grade at cul-de-sacs and knuckles shall be 0.8%.

\*\*C2U with residential frontage: 2,000 VPD. C2U without residential frontage: 10,000 VPD. C2U volume thresholds based on development context.

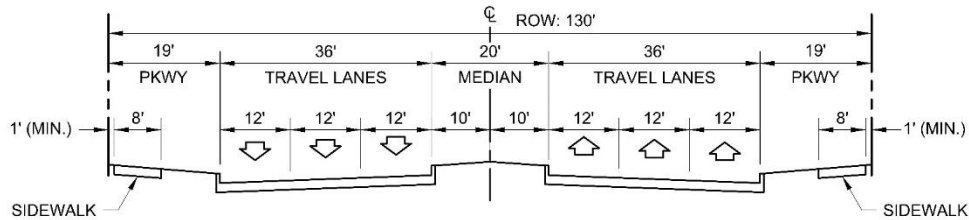
\*\*\*Refer to Figure 2-1 for additional information. Sidewalk widths shall vary if the corridor is identified as a Greenbelt Spine Trail (12 feet) or Arterial Trail (10-12 feet) in the Parks, Recreation, Open Space, Trails, and Streetscape Visioning Master Plan.

\*\*\*\*Landscaping and utility conduits shall be limited to within the ultimate median width of 20', and shall be excluded from the (2)-11' reserved medians regions.

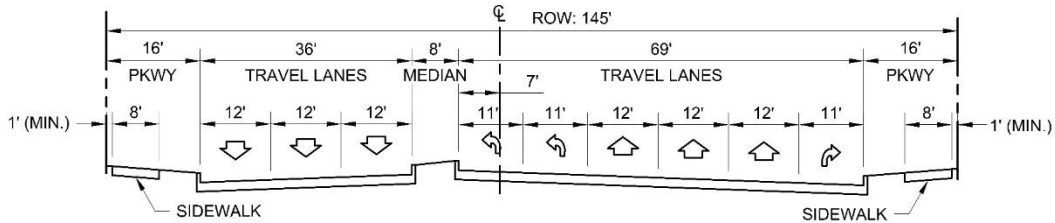
**P6D PRINCIPAL ARTERIAL (INTERSECTION)**



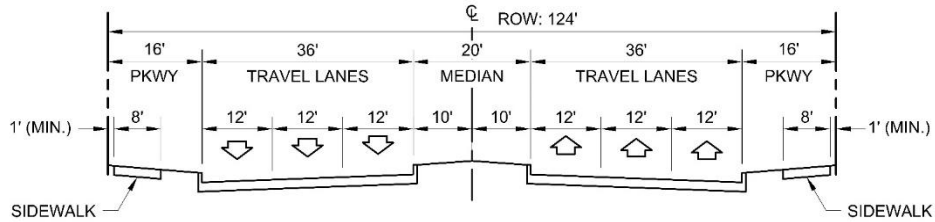
**P6D PRINCIPAL ARTERIAL (MIDBLOCK)**



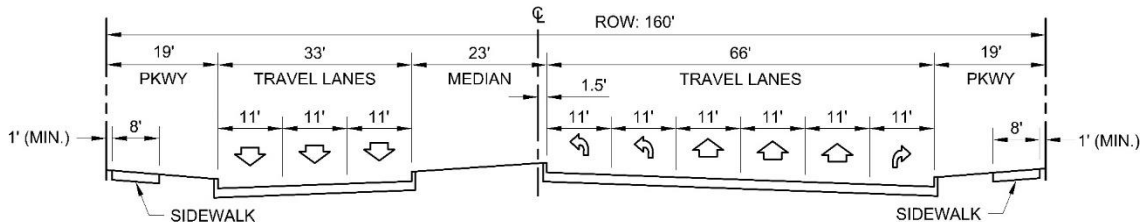
**M6D MAJOR ARTERIAL (INTERSECTION)**



**M6D MAJOR ARTERIAL (MIDBLOCK)**

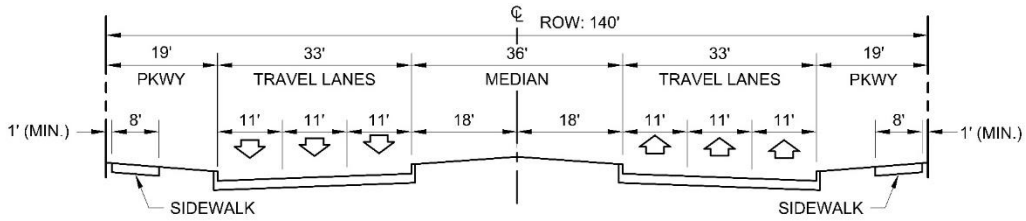


**G6D GREENWAY ARTERIAL (INTERSECTION)**

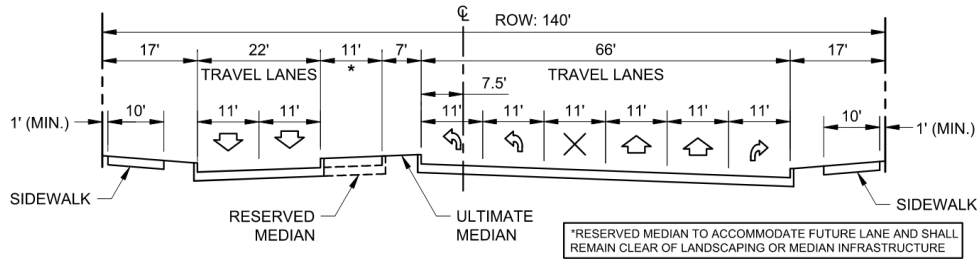


**Figure 2-1A – Major Arterial Roadway Typical Sections**

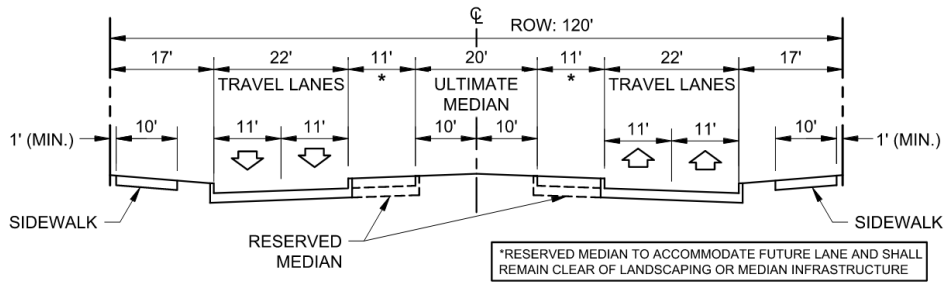
**G6D GREENWAY ARTERIAL (MIDBLOCK)**



**G4D GREENWAY ARTERIAL (INTERSECTION)**



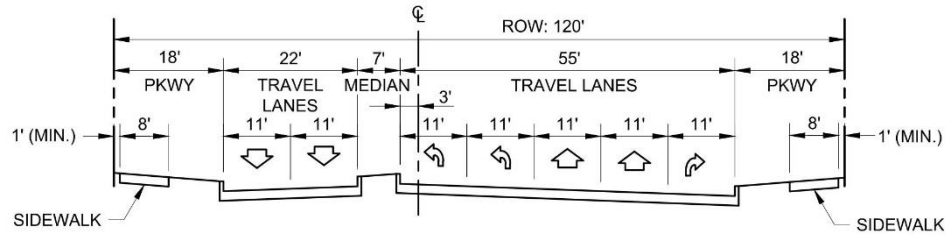
**G4D GREENWAY ARTERIAL (MIDBLOCK)**



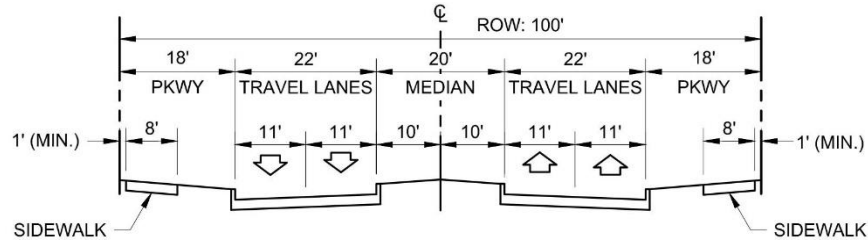
**Figure 2-1A – Major Arterial Roadway Typical Sections**



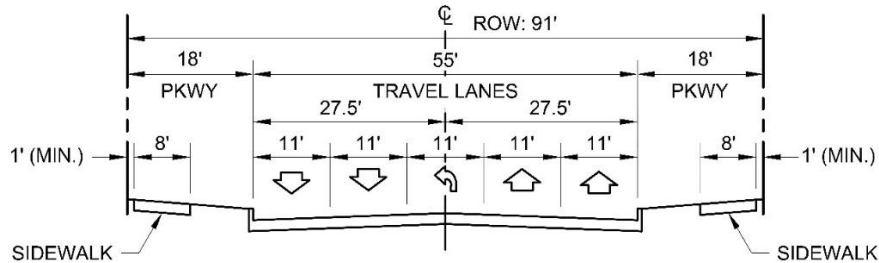
**M4D MINOR ARTERIAL (INTERSECTION)**



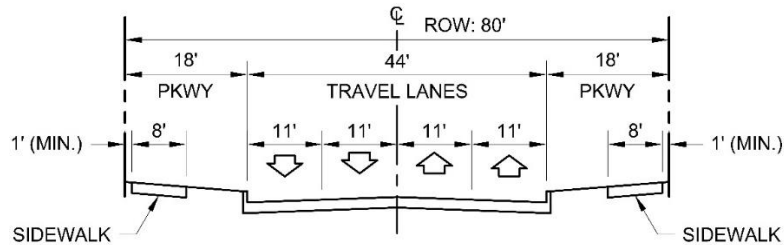
**M4D MINOR ARTERIAL (MIDBLOCK)**



**M4U MINOR ARTERIAL (INTERSECTION)**

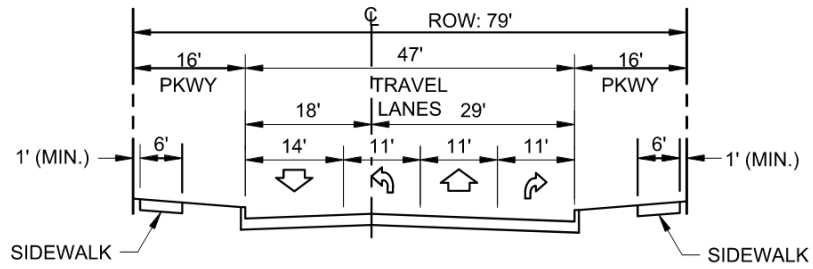


**M4U MINOR ARTERIAL (MIDBLOCK)**

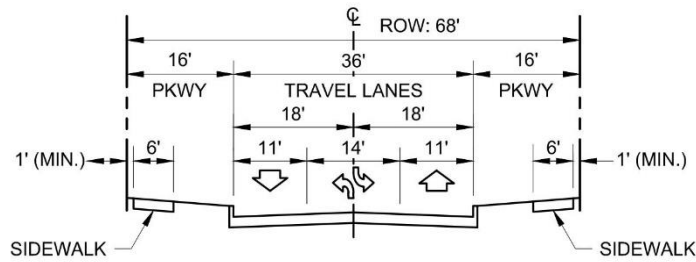


**Figure 2-1B – Minor Arterial Roadway Typical Sections**

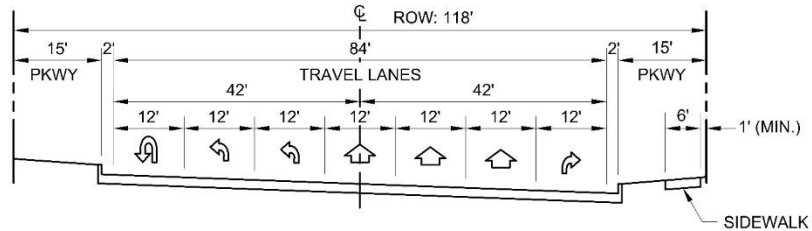
**M3U MINOR ARTERIAL (INTERSECTION)**



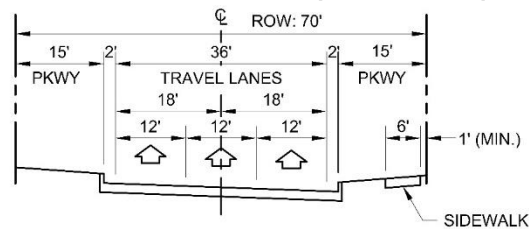
**M3U MINOR ARTERIAL (MIDBLOCK)**



**M3U-F MINOR ARTERIAL (INTERSECTION)**



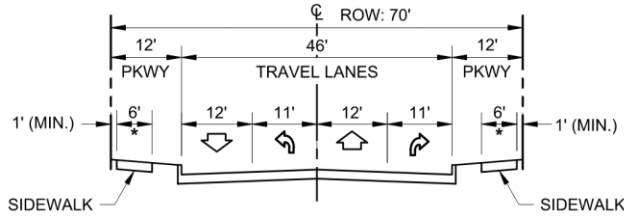
**M3U-F MINOR ARTERIAL (MIDBLOCK)**



**Figure 2-1B – Minor Arterial Roadway Typical Sections**

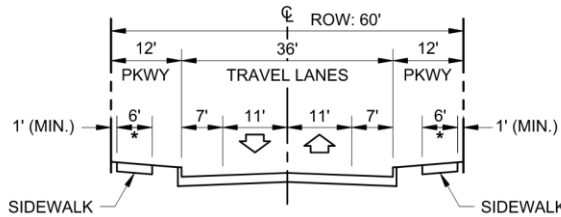
**C2U COLLECTOR (INTERSECTION)**

STREET PARKING PERMITTED



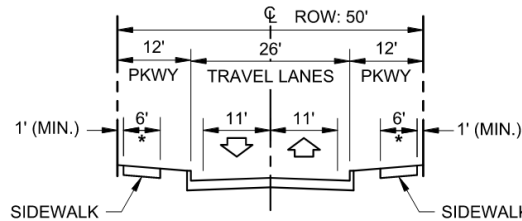
**C2U COLLECTOR (MIDBLOCK)**

STREET PARKING PERMITTED



**C2U COLLECTOR (INTERSECTION/MIDBLOCK)**

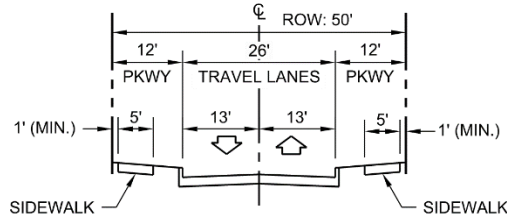
STREET PARKING PROHIBITED



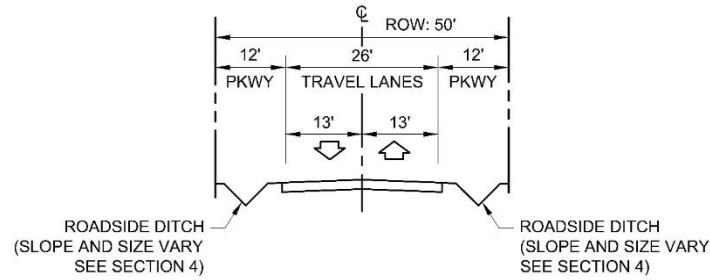
\*A SIDEWALK WIDTH REDUCTION TO 5' IS ALLOWED WHEN SINGLE FAMILY RESIDENTIAL DRIVEWAYS CONNECT TO A COLLECTOR ROAD. THIS REDUCTION IS TO DECREASE THE DRIVEWAY SLOPE FROM THE GUTTER LINE TO THE SIDEWALK.

Figure 2-1C – Collector Roadway Typical Sections

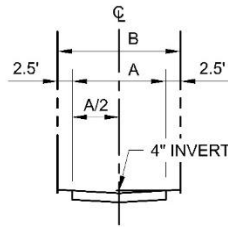
**R2U RESIDENTIAL STREET (INTERSECTION/MIDBLOCK)**



**R2U RURAL STREET (INTERSECTION/MIDBLOCK)**



**RA STANDARD ALLEY**



ALLEY WIDTH (A)	R.O.W. WIDTH (B)
12'	17'
15'	20'

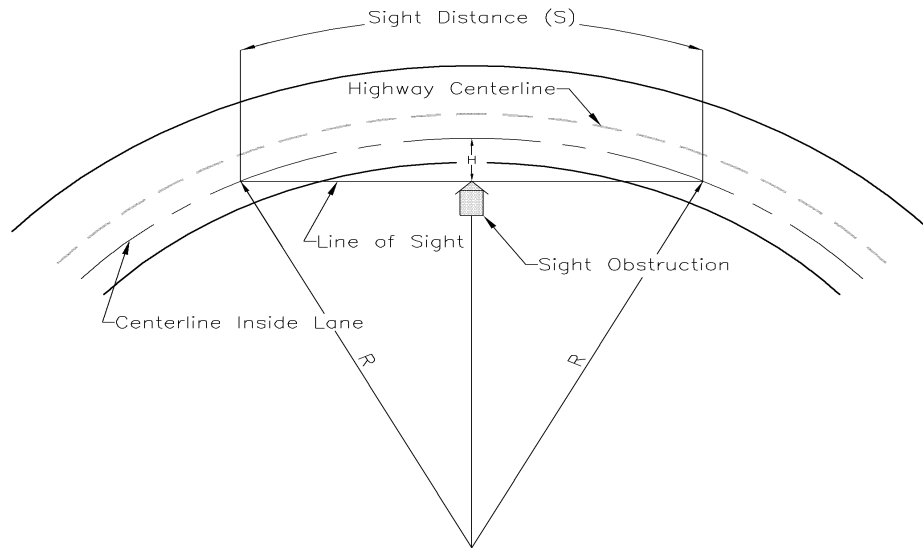
**Figure 2-1D– Residential Roadway Typical Sections**

### 2.2.B. Traffic Characteristics

1. Design Speed – The design speed is a primary factor in the horizontal and vertical alignment of roadways. Design features such as curvature, superelevation, turning movement radii, and sight distance affect roadway lane width, pavement width, pavement cross-slope, pavement crown, and clearances. Refer to **Table 2-1**.
2. Design Vehicle – Criteria for intersection and roadway design are based on varying sizes of vehicles and their corresponding operating characteristics. **Table 2-1** defines the design vehicle to be used for each roadway classification.

### 2.2.C. Horizontal Alignment

1. The recommended minimum horizontal centerline radius of curvature for vehicle design speed and pavement cross-slopes is shown on **Table 2-1**. Values shown in **Table 2-1** are in accordance with the guidelines in AASHTO's current edition of *A Policy on Geometric Design of Highways and Streets*. The minimum radii shown are based on a normal crown with no superelevation (–2%). Smaller radii may be used with the appropriate superelevation to maintain the design speed, with approval by the Director of Engineering.
2. To promote reduced speeds in residential neighborhoods, C2U roadways with residential frontage and all R2U roadways shall not exceed 600 feet in tangent length between curves, bends, and terminus points measured along the centerline of the roadway. For the purpose of determining tangent length under this paragraph, any curvature greater than the minimum horizontal radius based on the design speed of the roadway is considered tangent. For a single curve to satisfy this requirement it shall be designed with the minimum horizontal radius based on the design speed of the roadway and a minimum deflection angle of 30 degrees. For a reverse curve to satisfy this requirement it shall be designed with the minimum horizontal radius based on the design speed of the roadway, a minimum deflection angle of 15 degrees, and an offset equal to or greater than the pavement width plus 3 feet. A tangent is not required between reverse curves but may be provided if all other criteria are met. A roundabout designed to conform with all applicable requirements in **Section 2.3** may also satisfy this requirement by creating a roadway terminus point. Refer to **Section 2.3.I** for additional residential frontage requirements.
3. Reverse horizontal curves must be separated by a minimum 200-foot tangent section, and the centerline offset from the initial tangent to the final tangent must be a minimum of 30 feet.
4. Where retaining walls, traffic barriers, dense landscaping, or similar features are constructed on the inside of a horizontal curve, each obstruction should be evaluated for stopping sight distance, intersection sight distance, and horizontal offset requirements. **Figure 2-2** illustrates the affect that these features have on a driver's sight distance. To calculate horizontal offset requirements, follow the guidelines in AASHTO's current edition of *A Policy on Geometric Design of Highways and Streets*.



**Figure 2-2 – Horizontal Sight Distance Diagram**

#### 2.2.D. Vertical Alignment

1. The maximum allowable street grades for the City of McKinney are shown in **Table 2-1**. Grades that exceed the values in **Table 2-1** may be permitted on residential streets and where required by topographical and/or natural features, subject to approval by the Director of Engineering. Design of any roadway where sidewalks are required shall be in accordance with the Pedestrian Design Guidelines discussed in **Section 2.10**.
2. Vertical curves are utilized in roadway design to affect gradual change between tangent grades and will result in a design which is safe, comfortable in operation, pleasing in appearance, and adequate for drainage. Vertical curve alignment shall also provide stopping sight distance (SSD) in all cases. SSD is a function of design speed, perception-reaction time, and deceleration rate. To calculate SSD, follow the guidelines in AASHTO's current edition of *A Policy on Geometric Design of Highways and Streets*.
3. A vertical curve is required when two longitudinal street grades intersect at a point of vertical intersection (PVI) and the algebraic difference between those two grades is greater than 1%. Where the algebraic difference is less than or equal to 1.2% for residential streets (R2U) and alleys (RA) and less than or equal to 1% for all other roadway classifications, vertical curves are not required. To determine the minimum acceptable length of crest and sag curves follow the guidelines in AASHTO's current edition of *A Policy on Geometric Design of Highways and Streets*.
4. Minimum vertical curve values do not account for intersection sight distance for intersecting streets. Intersection sight distance for all intersecting streets shall be evaluated in accordance with **Section 2.3.C** and shall be considered when developing vertical curvature.

5. The minimum vertical clearance for all structures traversing over City of McKinney thoroughfares is 17.5 feet on State maintained roadways. Consideration shall be given to future roadway resurfacing which would decrease the clearance provided. A minimum of 10-foot vertical clearance shall be provided for all roadway crossings of hike and bike trails.
6. All divided arterials shall be profiled such that the ultimate median curb lines have a maximum elevation differential of 3 inches per 20 feet of median width. This is necessary to accommodate the installation of future median openings and turn lanes along arterials. Spot elevations and pavement cross-slope transitions for future lanes shall be included in the plans in order to verify median cross-slopes. In areas where there is no future need for a median opening, the Engineer may justify the use of a greater differential between median curb elevations. Any differential exceeding 3 inches per 20 feet of median width requires approval from the Director of Engineering.

#### 2.2.E. Cross-Sectional Elements

1. Pavement Cross-Slopes – All major and minor arterials shall have a cross-slope of 2%. The cross-slope can vary where there is a transition into or out of a maximum 2% superelevation. When superelevation is used as approved by the Director of Engineering, the maximum allowable rate of superelevation for roadways in the City of McKinney is 4%. Superelevation must be designed consistent with the guidelines in AASHTO's current edition of *A Policy on Geometric Design of Highways and Streets*.
2. Parking – Where parking lanes are required, a minimum width of 8 feet is required for such lanes.
3. Intersections – See **Section 2.3** for intersection design requirements, including intersection sight distance considerations.
4. Parkways – A parkway is the area between the edge of the roadway pavement and the ROW line that is reserved for public use. The parkway width varies for different roadway classifications, and is generally a minimum of 10 feet wide. Sidewalks and utilities are typically situated within the parkway of a thoroughfare. Refer to **Section 2.10** for additional information regarding sidewalks and other pedestrian facilities within the parkway. The cross-slope of all parkways shall be a maximum of 2%.
  - a. Fences, walls, screening devices, signs, and other structures shall conform to the Unified Development Code, and as amended.
  - b. Foliage of hedges, trees, and shrubs located in or encroaching into public ROW shall be maintained such that the minimum overhang above a sidewalk shall be 7 feet and the minimum overhang above an arterial or collector street shall be 14 feet.



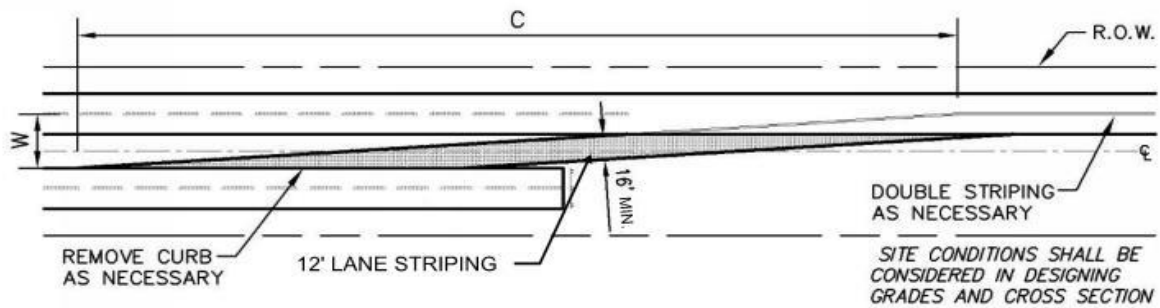
- c. Plants in the public ROW that will grow over 24 inches (when mature) above the adjacent street's curb shall conform to all the above requirements, where applicable. All landscape plans shall show all items required on the Plan Review Development Checklist in **Appendix B**, including the locations and types of such plants and the prescribed visibility triangles. Refer to **Section 7** for additional landscape requirements.
5. Side Slopes – In areas where the proposed improvements require grading outside of the street ROW in order to tie to existing ground, a maximum 4H:1V slope can be used for grading.
6. Clear Zone – A clear zone shall be provided for all streets. The clear zone is an unobstructed, relatively flat area provided beyond the edge of the traveled way for the recovery of errant vehicles. A minimum clear zone of 4 feet shall be provided from the face of the curb on tangent sections. A minimum clear zone of 6 feet shall be provided from the face of the curb on curved sections. Refer to the AASHTO's current edition of *Roadside Design Guide* and TxDOT's current edition of *Roadway Design Manual* for all other cases, including rural classifications.
7. Guardrails – Where clear zone requirements cannot be met, any combination of a sloping-faced curb that is 6 inches or shorter and a strong-post guardrail can be used where the curb is flush with the face of the guardrail up to an operating speed of 50 mph. Refer to the National Cooperative Highway Research Program (NCHRP) Report 537 for required clear zone widths and fixed object protection.

#### 2.2.F. Partial or Substandard Streets

1. Wherever a partial street has already been provided adjacent to an area to be subdivided, the other remaining portion of the street shall be platted with such subdivision. Where part of a street is being dedicated along a common property line where no roadway currently exists, the first dedication of ROW shall be of an adequate width so that the Developer shall be responsible for at least 24 feet of clear pavement width, or as considered necessary by the Director of Engineering. In cases where the ultimate typical section travel width is less than 26 feet (face of curb to face of curb), the Developer shall be responsible for the full width of clear pavement. Additional ROW and easements shall be dedicated as necessary to install signage and to perform grading activities.
2. All streets serving as the primary or secondary access point to a development shall meet current city standards.
3. Whereas the existing street is substandard in width, or a material other than concrete or asphalt, or a pavement surface not adequate for the proposed traffic, the existing street shall be improved to at least 24 feet of clear pavement width conforming with current design standards, or as required by the Master Thoroughfare Plan.

2.2.G. Tapers and Street Cross-Over Design

1. Street cross-overs are used on divided arterials to transition from divided to undivided sections of roadway. The minimum design speed to be provided for the transition shall be based on the roadway classification as summarized in **Table 2-1**. The transition should follow a straight-line taper for the cross-over. Street cross-over requirements can be found in **Figure 2-3**.



**Figure 2-3 – Cross-Over Design**

2. The required length of the transition is calculated using the following formulas:

$$L = \frac{WS^2}{60} \text{ (for } S \leq 40 \text{ mph)} \quad L = WS \text{ (for } S > 40 \text{ mph)}$$

$$C = L/2$$

Where:

L = Length of merging taper transition (feet) measured along the roadway centerline

W = Width of the offset (feet)

S = Speed (mph)

C = Length of cross-over (shifting taper) transition

3. For a shifting taper where the number of lanes will not be reduced, the length of the cross-over transition (C) shall be ½ of L. For a merging taper, the length of transition shall be equal to L. If both a lane reduction and cross over is required, the lane reduction by merging taper shall be completed prior to beginning the crossover (shifting taper).
4. Reverse curves and other alternative cross-over designs shall be reviewed on a case-by-case basis and approved by the Director of Engineering.

### 2.2.H. Dead-End Streets/Cul-de-Sacs/Stub Streets

1. All dead-end streets shall have a turn-around unless otherwise allowed below. Turn-arounds at the end of dead-end streets (cul-de-sacs) shall have the following circular driving surface and a street ROW.
  - a. Residential (R2U), surface diameter: 80 feet, ROW diameter: 100 feet
  - b. Commercial (C2U), surface diameter: 100 feet, ROW diameter: 120 feet
2. The maximum length of a dead-end street with a turn-around (cul-de-sac) shall be 600 feet, measured from the ROW line of the intersecting street to the center point of the turn-around.
3. If any residential lot fronts onto the dead-end portion of a street that will be extended in the future, a temporary turn-around that meets the standards described above shall be constructed at the end of the dead-end street within a temporary street easement. The following note shall be placed on the plat: "Cross-hatched area is temporary street easement for turn-around until street is extended (give direction) with future development of abutting property".
4. A stub street is an undivided dead-end street that will be extended in the future that does not have a turn-around. No residential lots shall front onto a stub street. Non-residential lots adjacent to a stub street shall have access to another street. If the length of a residential stub street exceeds the depth of the adjacent residential lots, it shall be temporarily blocked at the rear edge of the lots (or alley) with barrel-mounted barricade. If a non-residential stub street extends more than 100 feet beyond the last driveway on the street, it shall be temporarily blocked at the last driveway with barrel-mounted barricade.
5. Type 4 object markers shall be installed at the terminus of a residential stub street (maximum 5-foot spacing). A residential stub street shall also have a 24"x30" sign prominently posted at its terminus with black letters on a white background that states, "NOTICE – This street will be extended as part of a future development." Permanent Type III barricades shall be installed at the terminus of an arterial stub street. The installation and cost of these markers, barricades, and/or signs shall be the responsibility of the Developer.
6. To minimize risk created by infrastructure maintenance, dead-end streets with a turn-around (cul-de-sac) shall not cross bridges, multiple barrel/box culverts, culverts deeper than 10 feet to flowline, high pressure gas lines, high voltage electric lines, and other infrastructure that may require full street closures for maintenance as determined by the Director of Engineering.

### 2.2.I. Residential Frontage

1. Residential lots shall not front onto an arterial unless parallel access roads are provided. The minimum distance between adjacent curbs of the thoroughfare and the access road shall be 60 feet. Access road ROW shall be in addition to the thoroughfare ROW and access roads shall not connect to the adjacent thoroughfare.
2. Residential lots shall not front onto a collector within 100 feet of the ROW line of the nearest arterial.
3. Medians installed on undivided streets at entrances to subdivisions for aesthetic or any other purpose shall be a minimum of 8 feet wide and 100 feet long. Roadway pavement in each direction adjacent to the median shall be a minimum of 24 feet (face of curb to face of curb). No driveways for adjacent houses shall be permitted on these street segments within 150 feet of the curb line of the cross street. The median shall terminate at the ROW line of the intersecting thoroughfare.
4. Residential lots shall not front onto a roundabout, nor should the houses face the roundabout. Residential lot driveways shall not intersect with the roundabout or along any section of street within the splitter island.

### 2.2.J. Block Requirements

1. Street Block Length – Blocks shall not exceed 1,200 feet in length, measured along each ROW line from intersection street ROW line to intersection street ROW line. Blocks backing to an arterial shall not exceed 1,600 feet in length. In the case of non-rectangular blocks, each side of the block with lots fronting it shall not exceed 1,200 feet, measured between the vertices formed by the extension of ROW lines at each corner of the block. Blocks shall be further restricted so that they shall contain no more than 20 lots on one side. Blocks with a continuous series of lots longer than 1,200 feet, measured along one or more sides, may be required to be bisected by a pedestrian easement and a sidewalk. Blocks exceeding these dimensions shall be bisected by a minimum 25 foot wide common area and pedestrian access easement with a minimum 5 foot side sidewalk.
2. Street Block Width – Blocks shall be wide enough to allow two tiers of lots and shall have a block width no less than 200 feet, except when only one tier of lots is possible due to the size of the property or the need to back up to an arterial.

## 2.3. Intersections

### 2.3.A. Intersection Design

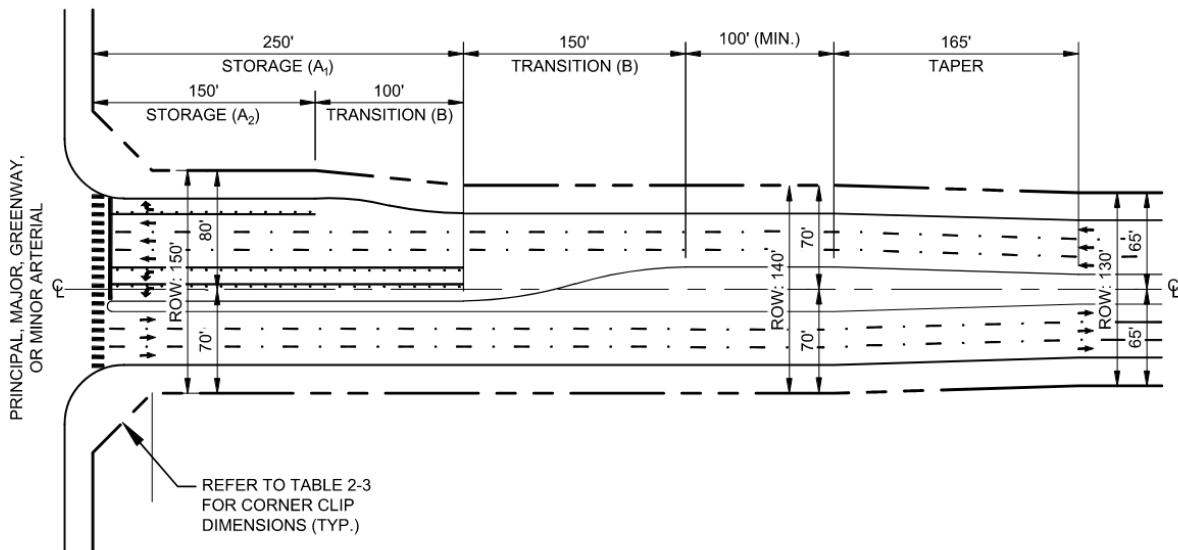
1. The main objectives in the design of an intersection are to facilitate the safety, convenience, and efficiency of the motor vehicles, bicycles, and pedestrians traveling through it. The following sections include design criteria and requirements for intersection and median opening design in the City of McKinney. Design of intersections shall consider the following:
2. Feasibility of a roundabout intersection (refer to **Section 2.3.E**) or other non-standard intersection versus a traditional signalized or stop-controlled intersection by performing a high-level intersection control evaluation during the preliminary planning of a proposed intersection. Intersection options and strategies considered should reduce the severity of potential conflicts and strategically optimize function for all intersection users including vehicles, pedestrians, and bicyclists.
3. Residential streets shall only intersect other residential streets or collector streets. Only arterial streets and collector streets shall intersect arterial streets.
4. Thru lanes shall line up across intersections with no offset.
5. The design shall fit the natural transitional paths and operating characteristics of drivers and vehicles.
6. Smooth transitions shall be provided for changes in direction.
7. Grades shall be relatively flat.
8. All types of sight distance shall be sufficient to enable drivers to prepare for and avoid potential conflicts.
9. On arterial and collector streets, intersections shall be evenly spaced to the greatest extent possible. Such an arrangement enhances the synchronization of signals, increases driver comfort, improves traffic operation, and reduces fuel consumption.

### 2.3.B. Intersection Geometry

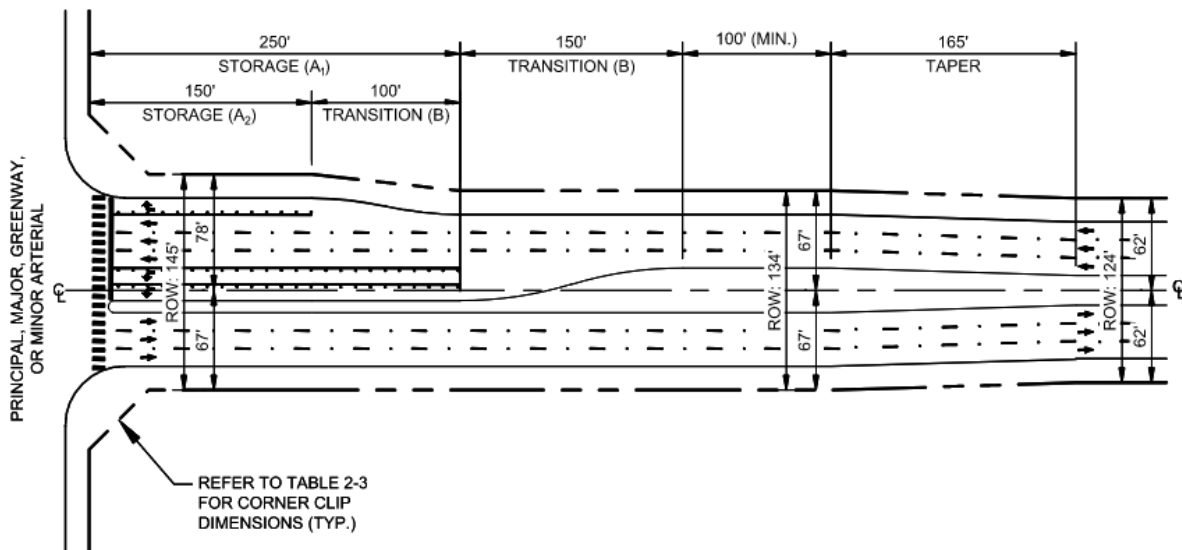
1. Intersection shall accommodate all existing and future pedestrian movements through intersection geometry
2. All arterial intersections shall intersect within 5 degrees of 90 degrees. All other intersections shall intersect within 10 degrees of 90 degrees.
3. Roadway alignment shall remain tangent upstream and downstream of an intersection for a minimum distance equal to the corresponding turn lane length (including taper) or 250 feet, whichever is larger.

4. The curb radius shall be 40 feet at the intersection of two arterials, and shall be 35 feet at the intersection of an arterial street with a collector. At all other intersecting residential streets, the curb radius shall be 25 feet.
5. Curb return profiles shall not exceed 2% in the vicinity of barrier free ramps. Profiles or spot elevations shall be submitted for each curb return at intersections involving collector and arterial roadways. Residential, collector, and arterial street profiles shall be limited to a maximum of 2% at the approach to collector street intersections.
6. Grading contours within and approaching major intersections shall not be less than 0.5% nor greater than 2.0%. When grading through an intersection, the minor roadway profile shall tie into the major roadway cross-slope while at the same time transition to match cross-slope with the major roadway profile grade. Intersection pavement details with spot elevations and pavement cross-slope transitions shall be called out for all intersections involving collector and arterial roadways. Gutter slope shall be a minimum of 0.5%.
7. Crosswalks shall pass through intersection prior to median nose.
8. Pedestrian accommodations within intersections shall conform with all applicable requirements in **Section 1.8** and **Section 2.10**.
9. Drainage inlets shall be installed to capture stormwater prior to entering arterial intersections with arterial or collector roadways. Intersection drainage shall conform to **Section 4**.
10. ROW widths for major intersections are larger than the standard mid-block ROW. This additional width allows for construction of added turn lanes to accommodate either current or future traffic conditions. Refer to **Figure 2-4** for intersection ROW widths for the corresponding roadway classification.

**P6D PRINCIPAL ARTERIAL (INTERSECTION)**



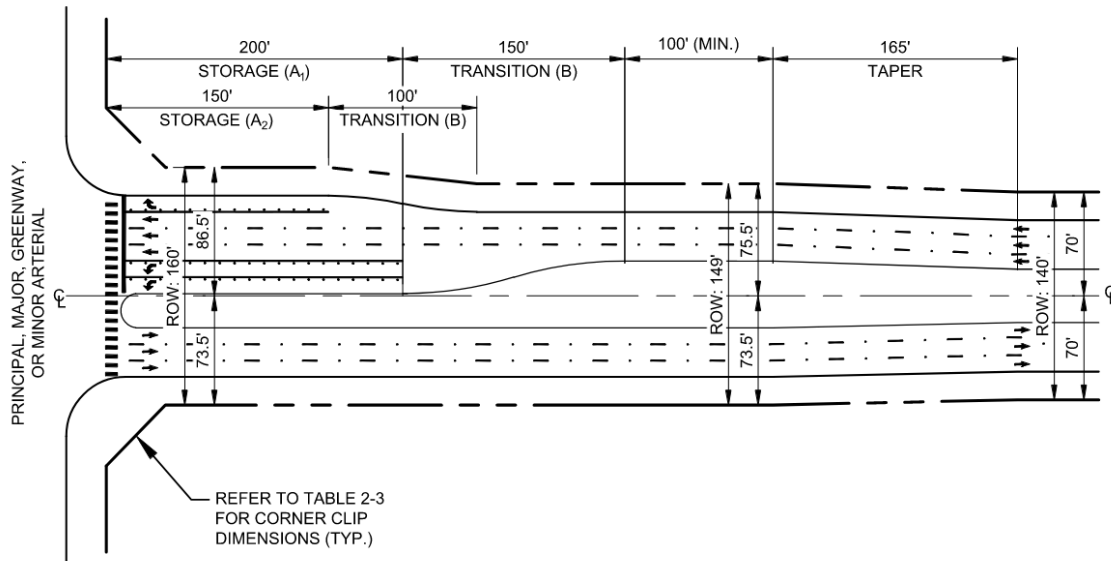
**M6D MAJOR ARTERIAL (INTERSECTION)**



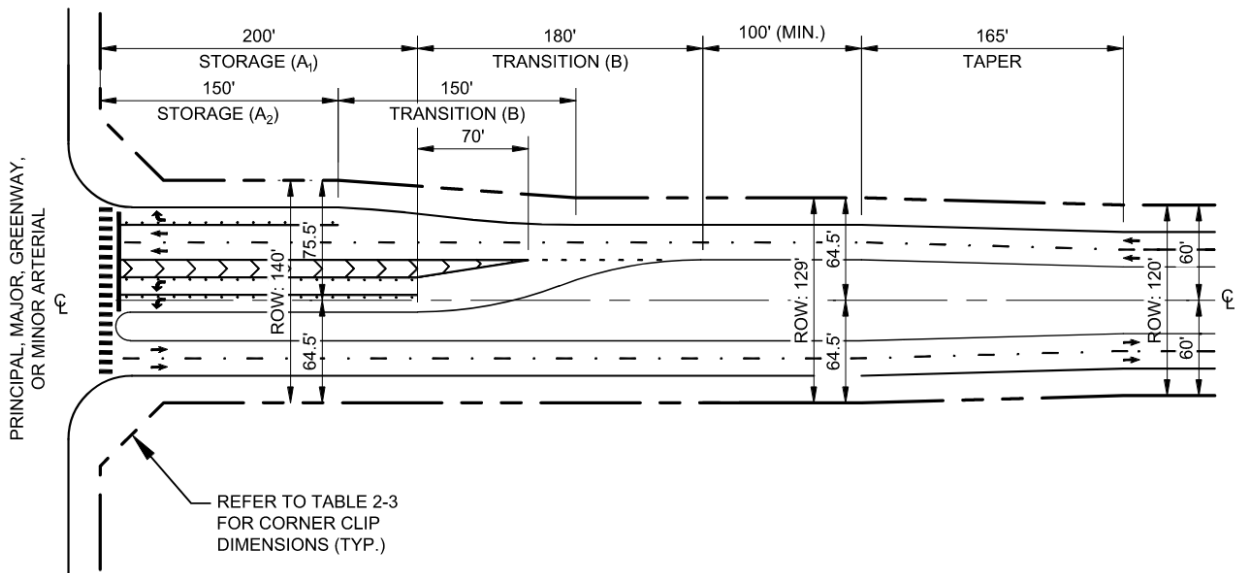
**Figure 2-4 – Intersection Layouts**



**G6D GREENWAY ARTERIAL (INTERSECTION)**



**G4D GREENWAY ARTERIAL (INTERSECTION)**



**Figure 2-4 – Intersection Layouts**

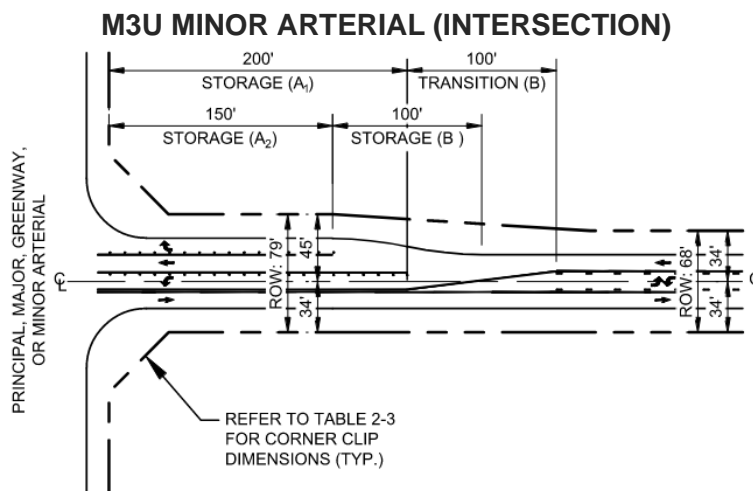
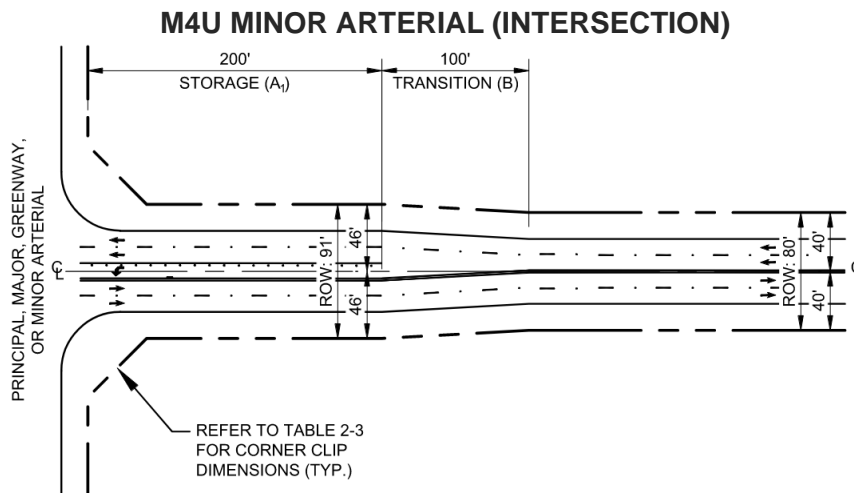
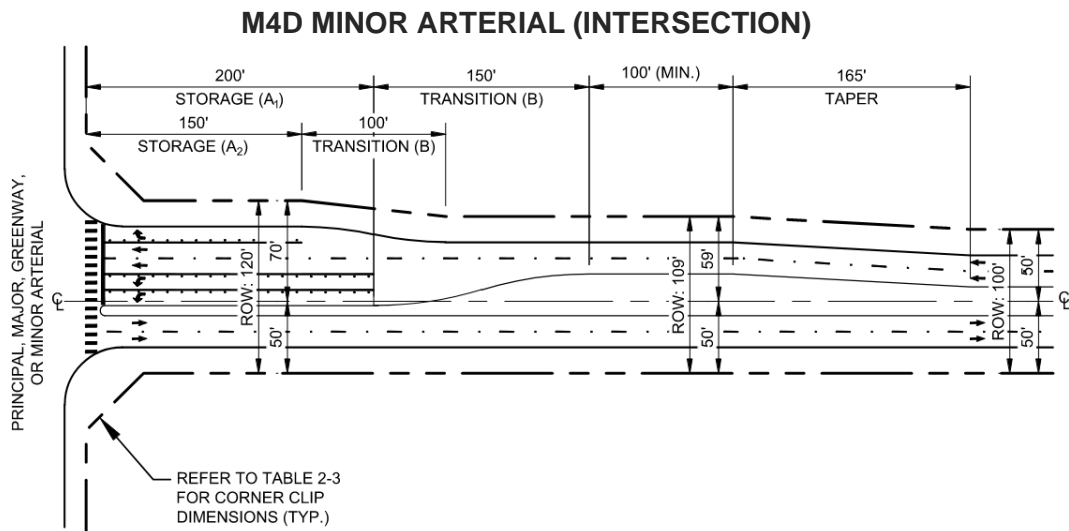
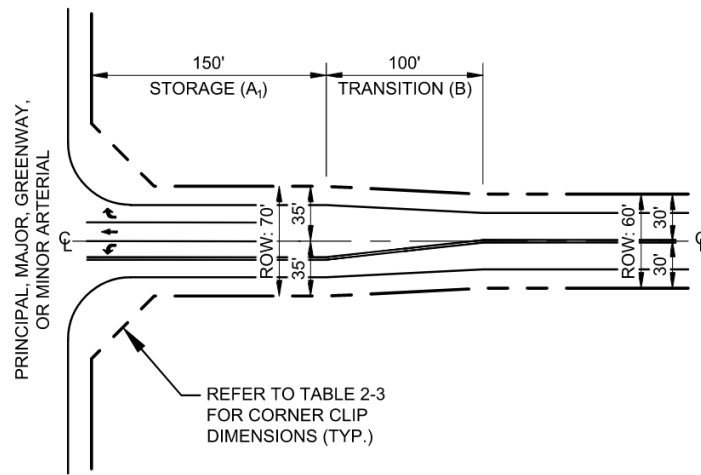
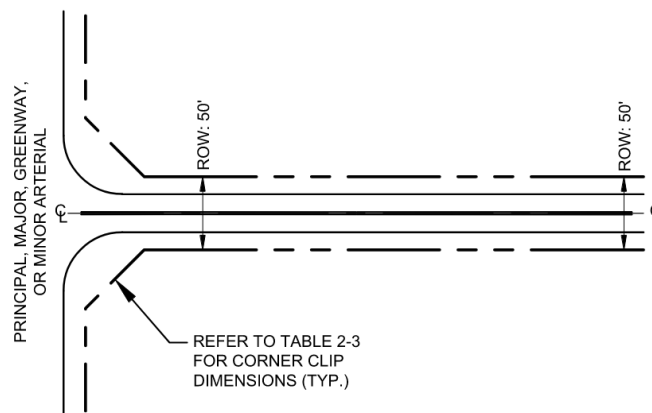


Figure 2-4 – Intersection Layouts

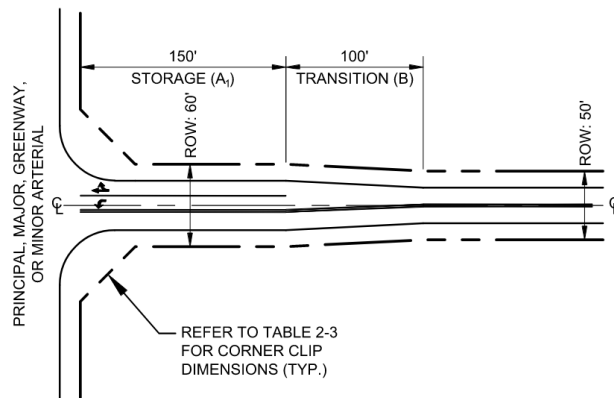
**C2U COLLECTOR (INTERSECTION)  
 STREET PARKING PERMITTED**



**C2U COLLECTOR (INTERSECTION, NON-MEDIAN OPENING)  
 STREET PARKING PROHIBITED**

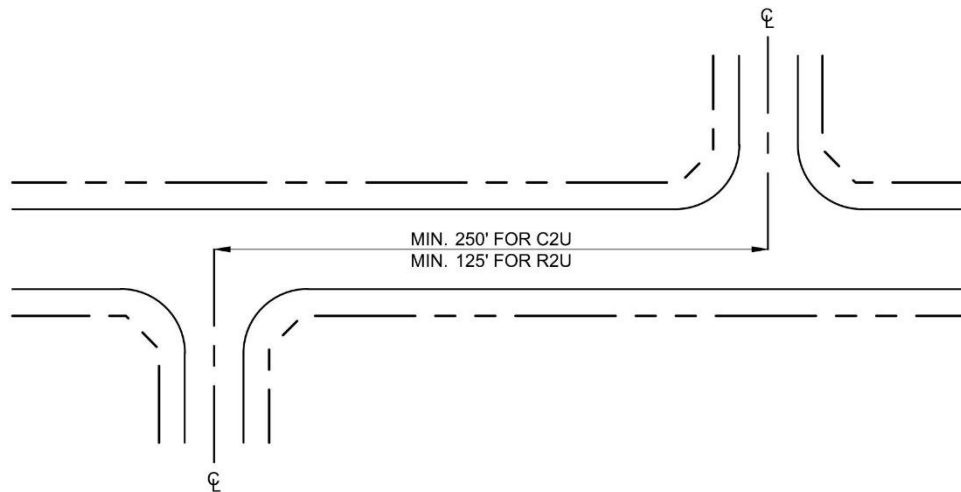


**C2U COLLECTOR (INTERSECTION, MEDIAN OPENING)**



**Figure 2-4 – Intersection Layouts**

11. Residential roadways that have offset intersections must have a minimum of 125 feet distance from centerline to centerline. Collector roadways that have offset intersections must have a minimum of 250 feet distance from centerline to centerline. Offset intersections shall be avoided on undivided arterial roadways. For offset intersections, pedestrian crossings shall not be located within the minimum distance street length. See **Figure 2-5**.



**Figure 2-5 – Offset Intersections**

### 2.3.C. Sight Distance and Visibility

1. Motorists should have an unobstructed view of roadways they are crossing. The minimum sight distance is related directly to design speed and to the distance traversed during braking, perception, and reaction times. The intersection sight distance can be calculated for different street or thoroughfare widths and for various grades.
2. Intersections contain multiple areas where potential conflicts can occur. The number of areas can be reduced by providing adequate sight distance, defined by the sight visibility line, in all directions of approaching traffic. Required intersection sight distances are shown in **Table 2-2**. **Figure 2-6** and **Figure 2-7** show the method for measuring vertical and horizontal intersection sight distance. The driver is assumed to be 14.5 feet behind the curb line of the intersection street. Sight visibility easements may be required during the platting process in order to achieve the values presented in **Table 2-2**. All intersection visibility requirements shall meet the guidelines for sight triangles in AASHTO's current edition of *A Policy on Geometric Design of Highways and Streets*.

Table 2-2 – Intersection Sight Distance

Design Speed (mph)	Sight Distance by Number of Lanes in Cross Section Near and Far Side (feet)*									
	2		3		4		5		6	
	Near	Far	Near	Far	Near	Far	Near	Far	Near	Far
30	290	335	-	-	-	-	-	-	-	-
35	-	-	335	415	335	415	335	440	-	-
40	-	-	-	-	385	530	-	-	385	560
45	-	-	430	530	-	-	-	-	430	630

\*Note: Intersection sight distances shown are for a stopped passenger car at grades 3% or less and based on the City’s typical roadway sections (including median). For other conditions, see AASHTO’s current edition of *A Policy on Geometric Design of Highways and Streets*.

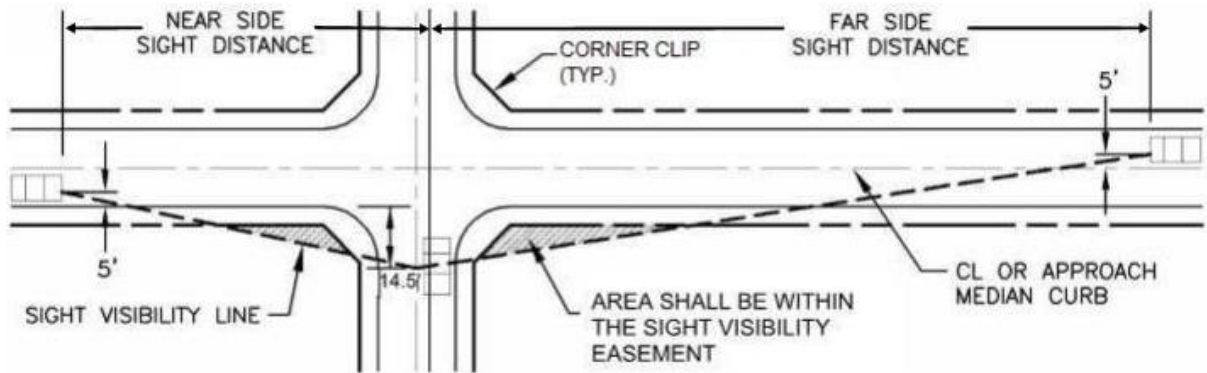


Figure 2-6 – Horizontal Intersection Visibility Triangles

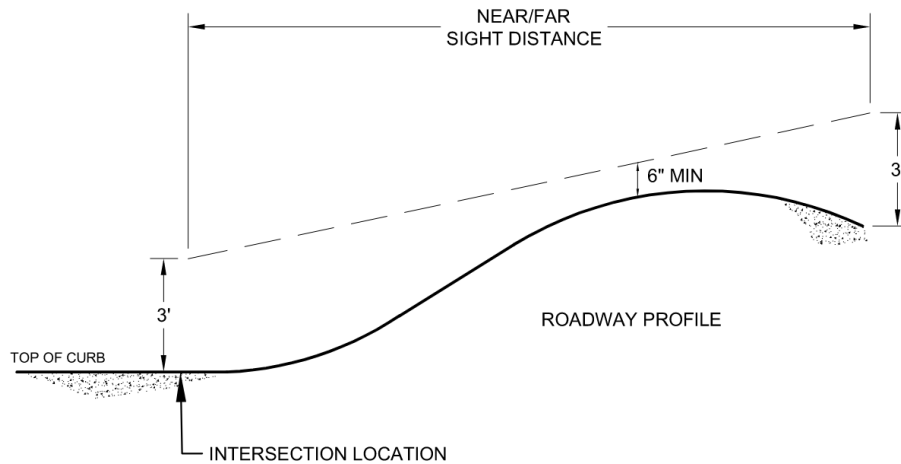


Figure 2-7 – Vertical Intersection Visibility Easements

- a. Sight visibility lines shall be provided on all corners of an intersection between two thoroughfares or an intersection between an alley and a thoroughfare.
- b. Sight visibility lines shall be provided where a driveway, an alley, or a stop-controlled thoroughfare intersects an uncontrolled thoroughfare and on any signalized intersection approach where right turn on red operation is permitted.
- c. No fence, wall, screen, sign, structure, foliage, hedge, tree, bush, shrub, berm, driveway, parking space, or any other item, either man-made or natural, shall be erected, planted, or maintained in a position that will obstruct or interfere with a driver's clear line of sight within a sight visibility easement.
- d. The City has the right to prune or remove any vegetation within public ROW, including within the sight visibility easement to abate a safety hazard and/or a nuisance.
- e. Vision at all intersections of thoroughfares shall be clear at elevations between 2 feet and 7 feet above the average gutter elevation within the sight visibility easement and meet AASHTO's current minimum requirements.
- f. In the case where the thoroughfare contains existing horizontal curvature, the intersection sight distance must be measured along the horizontal curve.
- g. Minimum vertical curve values do not account for intersection sight distance for intersecting streets. Intersection sight distance for all intersecting streets shall be evaluated in accordance with this section and shall be considered when developing vertical curvature.

#### 2.3.D. Corner Clips

1. Corner clips are a ROW dedication that shall be provided on all corners of an intersection between two thoroughfares or an intersection between an alley and a thoroughfare. This corner clip aids in street intersection visibility as well as provides sufficient room for sidewalks, barrier free ramps, and other street facilities. If the corner clip is within the sight visibility line, all sight distance requirements must be maintained.
2. All intersections shall have a ROW dedication\* as shown in **Table 2-3** and **Figure 2-8**.

Table 2-3 – Corner Clip Distance

Roadway Type	Intersection Type**	Distance (X) in feet***
P6D, M6D, G6D, G4D, M4D, M4U, M3U, M3U-F, C2U	Signalized	40
P6D, M6D, G6D, G4D, M4D, M4U, M3U, M3U-F, C2U	Not Signalized	25
R2U	Not Signalized	10
RA	Not Signalized	5
Unimproved Roadway	Not Signalized	30

\*Note the ROW dedication for the corner clip does not necessarily include the sight visibility easement as shown in **Figure 2-8**.

\*\*The Director of Engineering may determine corner clip requirements based on the ultimate intersection type.

\*\*\*The corner clip shall have the same dimension on all corners of the intersection, based on the largest classification roadway at the intersection.

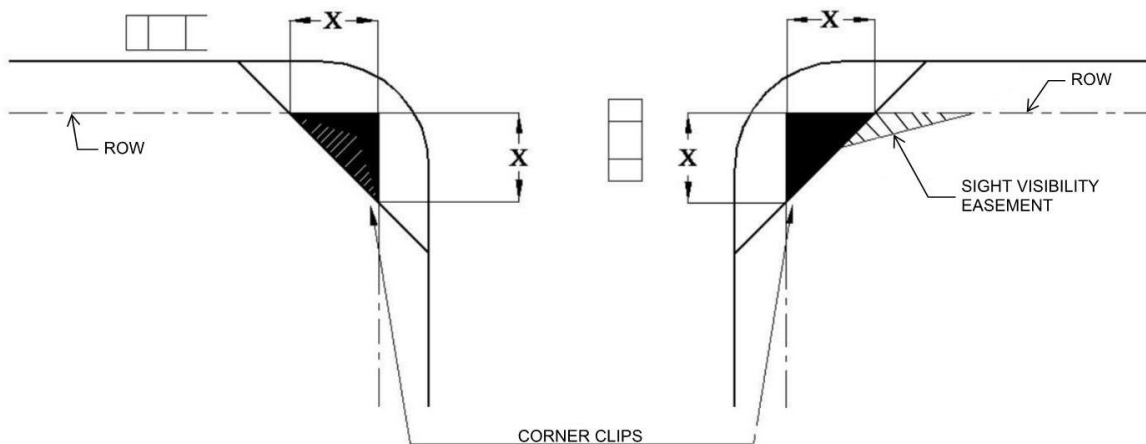
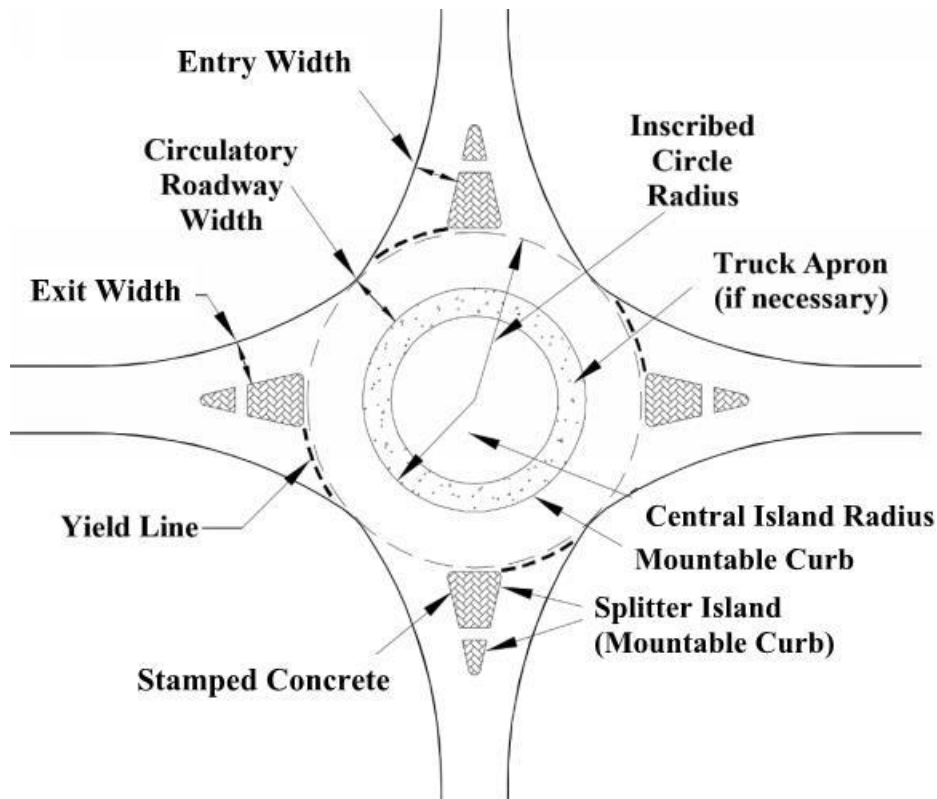


Figure 2-8 – Corner Clips for an Intersection



### 2.3.E. Roundabouts

1. Roundabouts are a form of circular intersections in which traffic travels counterclockwise around a central island. Features include yield control of all entering traffic, channelized approaches, and geometric features to induce desirable vehicle speed. The design of a roundabout is an iterative process and requires high level discussion between all parties involved. The City recognizes the following documents below as resources for modern roundabout design. Criteria provided in this section is intended to enhance guidance contained within the following documents.
  - a. Current edition of NCHRP Research Report 1043, *Guide for Roundabouts*; and,
  - b. Current edition of *Texas Manual of Uniform Traffic Control Devices (TMUTCD)*.
2. Operational Analysis of a roundabout allows a transportation analyst to assess the operational performance of a facility, given information about the usage of the facility and its geometric design elements. Refer to Chapter 8 of the current edition of NCHRP Research Report 1043 for further information pertaining to Operational Analysis techniques. An operational analysis shall be provided for all proposed roundabouts, including the construction year, interim year (construction year + 10 years) and design year (construction year + 20 years). Projected traffic volume at a given intersection shall align with the latest version of the City's Thoroughfare Plan and any available forecasted ADTs on the connecting corridors. The recommended roundabout lane configuration shall be determined within the operational analysis. The operational analysis results for the proposed lane configuration of the roundabout shall include the following:
  - a. Average Control Delay (s/veh) per approach and overall;
  - b. Level of Service (LOS) per approach and overall, and
  - c. Volume-to-Capacity Ratio. Any entry design presented with a volume-to-capacity ratio greater than 0.85 will require written authorization from the Director of Engineering.
3. Geometric Design
  - a. The geometric design of a roundabout requires a balance of many design objectives: safety, operational performance, and accommodation of a design vehicle. To achieve this, roundabout geometry shall include the typical features shown in **Figure 2-9**.



**Figure 2-9 – Typical Roundabout**

- b. All roundabouts shall be designed to accommodate the design vehicle making all possible entry and exit movements within the roundabout limits. The design vehicle shall be accommodated by utilization of both the circulating lanes and truck apron (if provided).
- c. Inscribed Circle Diameter is the distance across the roundabout defined by the outer curb of the circulatory lanes. This feature accommodates design vehicle, traffic volume, and speed control. The following dimensions from **Table 2-4** shall be used for inscribed circle diameter. Any deviation from these values will require written authorization from the Director of Engineering.

**Table 2-4 – Inscribed Circle Diameter**

Type of Roundabout	Design Vehicle	
	Fire Truck*	WB-67 Truck/Trailer**
Mini-Roundabout	80'-100'	80'-100'
Compact Single-Lane	100'-115'	100'-115'
Single-Lane	120'-145'	120'-145'
Multilane (2 or 3 lanes)	150'-180'	

\*Contact the Engineering Department for current fire vehicle standards.

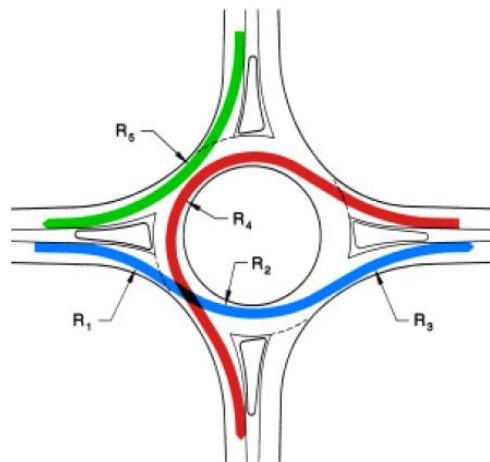
\*\*WB-62 shall be the design vehicle for G4D, M4D or narrower corridors unless required otherwise by the City.

- d. The roundabout shall be designed to maintain the fire truck wheel paths on-pavement without having to use the truck apron, splitter islands or perimeter curbing with the exception of a mini-roundabout.
- e. Approaches
  - i. Approaches, entry and exit, are defined as areas where the roadway section becomes atypical in an effort to control vehicle speed. The approach width is measured from the point where the entrance line intersects the left edge of the circulating lanes to the right curb line. Refer to the City of McKinney Construction Standard Details for additional information.
  - ii. Driveways, alley connections, and on-street parking shall not be permitted within the limits of a roundabout approach when a splitter island is also present within those limits.
- f. Circulating Lanes
  - i. Lane widths shall remain consistent throughout the roundabout. Excess lane width shall be avoided. Parking shall be prohibited within limits of the circulating lanes. Refer to the City of McKinney Construction Standard Details for additional information.
  - ii. Circulating lanes shall maintain a typical 1.5% cross-slope and drain to exterior curb, where feasible. The cross-slope can vary where there is a transition into or out of the circulating lanes. Cross slope transitions must be designed consistent with the guidelines in AASHTO's current edition of *A Policy on Geometric Design of Highways and Streets*. As a rule-of-thumb, the cross-slope should not change more than 0.5% over a circulating distance of 25 feet as measured from the center of the circulating lane/width.

- g. Truck Apron/Central Island
  - i. Truck apron shall be provided to allow for an additional traversable area around the central island for the largest anticipated design vehicle. When sizing the truck apron, a minimum of a 1-foot offset distance from the design vehicle wheel path to interior central island curb shall be provided. The pavement design for the truck apron shall assume loading conditions similar to the circulating lanes. Refer to the City of McKinney Construction Standard Details for additional information.
  - ii. The central island mound is meant to enhance driver recognition of the roundabout upon approach. The central island can also be enhanced aesthetically using landscaping. Refer to Chapter 14.4 of the current edition of NCHRP Research Report 1043 for further information.
  - iii. Like the circulating lanes, the truck apron shall maintain a 1.0% slope downward towards outside curbs. The first 6 feet of the central island shall maintain a 12:1 slope downward towards outside curbs.
- h. Splitter Islands
  - i. Raised splitter islands shall be provided on all single-lane and multilane roundabouts. They are meant to provide refuge for pedestrians and guide the traffic safely into the roundabout. Refer to the City of McKinney Construction Standard Details for additional information.
- i. Crosswalks
  - i. Crosswalks shall meet all applicable pedestrian accommodation requirements. Refer to **Section 1.8** and **Section 2.10**. Refer to the City of McKinney Construction Standard Details for additional information.
  - ii. Raised crosswalks will be considered by the City on a case-by-case basis.
  - iii. Enhanced pedestrian devices at crosswalks shall be provided for roundabouts within 1,500 feet of an elementary school or a middle school, a park, a senior center, or where the City deems necessary to provide for the enhanced safety of pedestrians at a crosswalk.
- j. Pavement Markings
  - i. Pavement markings at mini-, single-, and multilane roundabouts shall comply with the current City of McKinney Construction Standard Details.
- k. Signage
  - i. Signage at mini-, single-, and multilane roundabouts shall comply with the current City of McKinney Construction Standard Details .

4. Performance Checks

- a. Performance checks are important in determining if the design meets the intent of the roundabout objectives. The engineer shall prepare performance checks for fastest path, design vehicle and sight distance and visibility when designing a roundabout.
- b. Fastest path calculations shall adhere to Chapter 9.4.1 of the current edition of NCHRP Research Report 1043. Values calculated for the vehicle paths, R1, R2, R3, R4, and R5, as shown in **Figure 2-10**, shall meet a maximum of 23 mph for a single-lane roundabout and a maximum of 28 mph for a multilane roundabout. The relative speed between vehicle paths shall be minimized such that maximum differential between paths (R1/V1 vs R2/V2 and R2/V2 vs R3/V3) shall be no more than 10 mph.



**Figure 2-10 – Vehicle Path Radii**

- c. Design vehicle calculations shall be verified using AutoTURN, AutoTrack, or similar truck-turning template software that utilizes AASHTO 2018 vehicle turn templates. Turning movements for each approach (left turn, thru movement, and right turn) shall be verified with the wheel paths, and vehicle body envelopes depicted within the design file(s). U-turns may also be required by the City on a case-by-case basis.
- d. Sight distance and visibility calculations shall adhere to Chapter 9.5 of the current edition of NCHRP Research Report 1043. Within a roundabout, sight distance lines shall be provided at the entry approach (both stopping and intersection sight distance), along the circulatory lanes, and to the crosswalk at the exit approach. For additional guidance, refer to **Section 2.3.C** for sight distance and visibility at an intersection.
- e. For skewed intersection designs, multilane roundabouts, and right turn yielding bypass lanes, the view angles shall adhere to Chapter 9.5.4 of the current edition of NCHRP Research Report 1043.

- f. For multilane roundabout entries and exits the path overlap scenario shall adhere to Chapter 9.6 of the current edition of NCHRP Research Report 1043.
5. Construction Considerations
    - a. Mini-Roundabout - The highest point of the traversable central island of a mini-roundabout shall not exceed an 8-inch maximum rise relative to the lowest elevation of the circulatory roadway pavement along the perimeter of the traversable center island. This 8-inch height includes the vertical height of any rollover/mountable curb along the perimeter of the traversable center island. The high point elevation shall exceed a minimum of a 6-inch rise relative to the lowest elevation of the circulatory roadway pavement along the perimeter of the traversable center island. In no way shall the slope of the traversable center island exceed 4.0% in any direction.
    - b. Single-Lane Roundabout - The longitudinal joints shall be radial within circulating lanes and truck apron and shall not exceed maximum joint spacing as specified in the City of McKinney Construction Standard Details. Circular joints shall be utilized at centers or edges of lanes within circulating lanes. Transverse joints within circulating and truck apron shall not exceed maximum joint spacing, or fall below minimum joint spacing, as specified in this manual. Construction joint shall be utilized to separate all approaches from circulating lane and circulating lanes from truck apron. The interface between the interior mountable curb and the truck apron/central island pavement shall provide a keyway construction joint with radial reinforcement extended from the circulating lane pavement two feet into the truck apron/central island pavement.
    - c. Multilane Roundabout - The joints shall be radial within the interior circulating lane and truck apron and shall not exceed maximum joint spacing as specified in this manual. At exits, the jointing pattern shall complement the pavement markings where the longitudinal joints direct two exit lanes from the circulatory to the exit, known as a pinwheel jointing pattern. Construction joints shall be utilized to separate all approaches from circulating lanes and circulating lanes from the truck apron.
    - d. Within circulating lanes and truck apron, all steel reinforcement shall be placed radially and longitudinally to circulating traffic. Refer to **Section 3.1** for roundabout jointing plan requirements.
    - e. Drop slabs/sleeper slabs shall be provided beneath all mountable splitter island locations. No doweled connection shall exist between splitter island and the travel lanes. Refer to City of McKinney Technical Specifications and Construction Standard Details for drop slab dimensions and splitter island connection.
  6. Roundabout lighting shall be in accordance with **Section 2.11.D**.

## **2.4. Median Openings**

### **2.4.A. General**

1. Median openings play a critical role in the operation and safety of divided roadways. They also provide important points of access to adjoining property. Each median opening should be evaluated based on roadway flow and capacity.
2. Median openings on divided thoroughfares shall be provided at dedicated street intersections and at private drives only where they conform to the City's spacing requirements. All median openings shall be accompanied by a left-turn lane for the driveway or street. The design of median openings and left-turn lanes shall accommodate potential future left-turn lanes that might serve undeveloped land.
3. Median openings and left-turn lanes (including median pavers and traffic control devices) constructed to serve private drives and new roadways shall be paved to City standards, inspected by City inspectors, and paid for by property owners served by the median opening. Median noses shall be constructed monolithic with the street per the City of McKinney Construction Standard Details. Where the median width is 6 feet or less in width the full median shall be paved with stamped concrete.
4. All median openings on State highways are subject to review and approval by TxDOT and shall be designed in accordance with the TxDOT Roadway Design Manual at a minimum.

### **2.4.B. Median Spacing Requirements**

1. Minimum median opening spacing requirements is 525 feet (nose to nose). Median openings shall be a minimum of 20 feet wider than the width of the driveway which they are serving with a minimum median opening width of 60 feet. Median openings shall accommodate all turning paths and crosswalks. They may be greater than 60 feet where necessary to accommodate turning paths and crosswalks subject to approval by the Director of Engineering. All median openings shall be centered on the driveway. Median openings occurring at the boundary of municipalities shall seek joint concurrence for median opening spacing requirements.

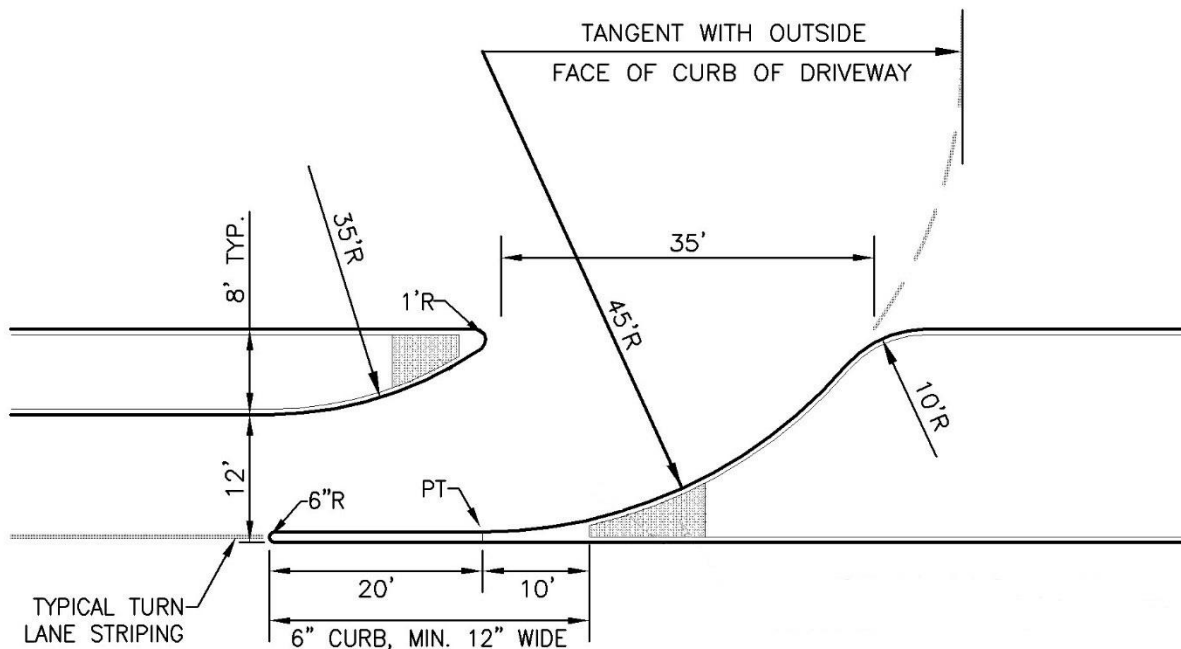
### **2.4.C. Cross-Slope/Grade Breaks**

1. The maximum longitudinal grade break (algebraic difference) for unsignalized non-city street median openings is 4%. During design of divided thoroughfares, spot elevations shall be provided along the median at 100 foot intervals in order to ensure that the addition of future travel lanes, left turn lanes, and median openings can be constructed without exceeding the 4% maximum grade break.



2.4.D. Directional Median Openings

1. In locations where full median openings are not permitted, the use of a one-way left turn lane may be appropriate. This would permit vehicles to turn left from the major thoroughfare into the driveway but would not permit vehicles exiting the driveway to pass through the opening. Such an opening would only be permitted where the opening plus required storage and transition can be provided without affecting any other opening or intersection. The design of the one-way opening shall be as shown in **Figure 2-11** and subject to approval by the Director of Engineering. A minimum spacing of 10 feet shall be required between adjacent and opposite one-way left turn lanes.



1. ALL DIMENSIONS ARE TO FACE OF CURB.
2. ADDITIONAL CONSIDERATIONS SHALL BE MADE FOR WIDER MEDIANS AND OVER-SIZED DRIVES.
3. STANDARD TURN LANE STORAGE AND TRANSITION LENGTHS SHALL BE MEASURED FROM THE PT.
4. APPROPRIATE SIGNAGE BASED ON MUTCD STANDARDS AND SITE LOCATION TO BE DETERMINED AT DESIGN STAGE.

**Figure 2-11 – One-Way Left Turn Lane Detail**

2.5. Turn Lanes

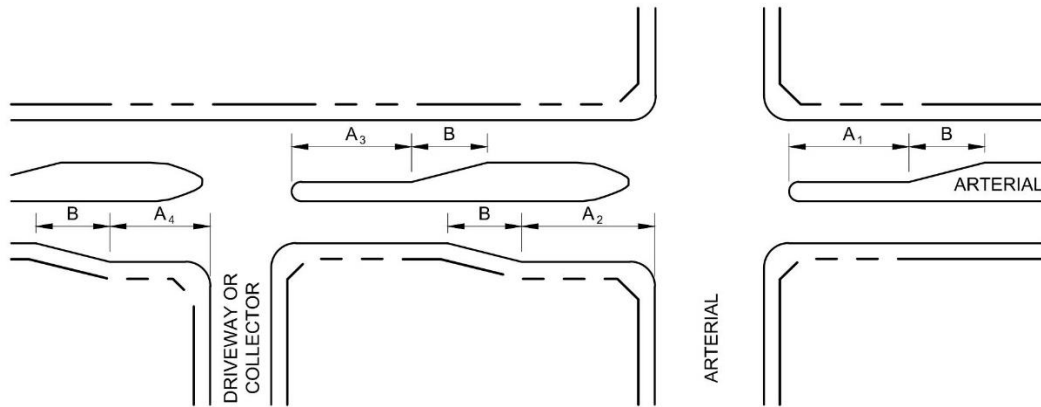


Figure 2-12 – Intersection Design Diagram

Table 2-5 – Minimum Turn Lane Design Requirements

Roadway Type	Turn Lane A <sub>1</sub> (feet)	Turn Lane A <sub>2,3</sub> (feet)	Turn Lane A <sub>4</sub> (feet)	Turn Lane Single / Dual B (feet)
P6D	250	150	100	100 / 150
M6D	250	150	100	100 / 150
G6D	200	150	100	100 / 150
G4D	200	150	100	100 / 180
M4D	200	150	100	100 / 150
M4U	200	150	100	100
M3U	200	150	100	100
M3U-F	See TxDOT current edition of <i>Roadway Design Guide</i> and Specifications			
C2U	150	150	100	100
R2U	N/A	150	100	100

2.5.A. Left Turn Lanes

1. Left turn lanes shall be provided for all median openings and intersections on divided roadways, and undivided roadway with future median openings (e.g. SH 5, FM 1461, etc.). Left turn lanes shall also be provided on undivided minor arterial and collector roadways at their intersection with arterial roadways. Left turn lanes shall be provided for all existing driveways, including private driveways.

2. All left turn lanes shall be 11 feet in width. Larger width may be required to accommodate larger vehicles as determined by the Director of Engineering. Left turn storage lengths are sized to store the number of vehicles expected to queue in the lane during an average peak period. Required left turn storage and transition lengths are provided in **Table 2-5**. On TxDOT roadways refer to Chapter 3 of the current edition of TxDOT *Roadway Design Manual* for left turn lane requirements. Dual left turn lanes are required for all arterial/arterial intersections and are also required when peak hour turning volumes exceed 250 vehicles.
3. All left turn lane storage lengths are minimum requirements. Additional length may be required based on traffic volumes or TIA storage requirements.
4. All dual left turn lane storage and transition lengths shall follow the dimensions shown in **Table 2-5** for the respective roadway classifications.
5. On an interim 2-lane undivided arterial roadway, interim left turn lanes shall be provided at all planned median opening locations as determined by the Director of Engineering. Streets or driveways without left turn lanes shall be signed as such both on the arterial and on the street or driveway. Construction of an interim left turn lane does not relieve the responsibility for constructing a permanent median opening and left turn lane. Interim left turn lanes are not required at residential driveways.

#### 2.5.B. Right Turn Lanes

1. Right turn lanes shall be provided on arterial roadways at all intersecting streets and driveways. All right turn lanes shall be 11 feet in width. Additional ROW shall be required adjacent to right turn lanes such that parkway width is maintained. Right turn storage lengths shall be sized to store the number of vehicles expected to queue in the lane during an average peak period. Minimum required right turn storage and transition lengths are found in **Table 2-5**. On TxDOT roadways refer to Chapter 3 of the current edition TxDOT *Roadway Design Manual* for right turn lane requirements.
2. A minimum tangent section of 30 feet shall be provided between the preceding driveway or cross street curb return and the taper of a right turn lane.
3. Right turn lane storage lengths are minimum requirements. Additional length may be required based on traffic volumes or TIA storage requirements.
4. All right turn lanes adjacent to bike lanes shall have a 175-foot transition. See **Figure 2-4**.

## **2.6. Access Management**

2.6.A. Roadways within the City of McKinney are required to provide some level of access to abutting properties. Before designing a roadway, it is important to establish the extent and needs of all its anticipated users. Once those needs are established, steps should be taken to protect the ability of the roadway to serve the users at the desired level of service from future changes along the corridor. The location, density, and type of future development, median openings, and cross access needs along a roadway should be anticipated regardless of its current physical setting.

2.6.B. Access management is the systematic control of the location, spacing design, and operation of intersections, driveways, median openings, and street connection. By managing roadway access, the life of roadways can be extended, and safety increased resulting in a reduction in delay and congestion. The goals of access management are accomplished by applying the following principles:

1. Provide a functional roadway system;
2. Limit direct access to major roadways;
3. Promote intersection hierarchy;
4. Locate traffic signals to favor through movements;
5. Preserve the functional area of intersections;
6. Limit the number of conflict points;
7. Separate traffic conflicts;
8. Remove turning vehicles from through traffic lanes;
9. Use non-traversable medians to manage left turn movements; and,
10. Provide a supporting street and circulation system.

2.6.C. Roadway designs shall ensure the following access management and connectivity goals are met:

1. Create a well-connected series of collector roadways within the one-mile arterial grid;
2. Establish a roadway network that moves vehicular traffic with a high-quality level of service while offering safe mobility for all modes of transportation;
3. Create an internal network of streets, rather than a series of seemingly disconnected roadways; and,
4. Integrate connections and linkages between streets, alleys, and trails within the transportation network.

To achieve these goals, the following priorities and outcomes shall guide the development of collector and residential streets:

1. Collector and residential streets should serve principally to provide neighborhood connections within and between subdivisions.
  2. Neighborhoods shall aim to be connected to one another through a woven street system that offers multiple external access points.
  3. The street network created by collector and residential streets should encourage a mix of premium lot types, including cul-de-sac lots, lots fronting to neighborhood amenities, or lots backing to open space. Cul-de-sacs, in particular, should be limited and used when the presence of physical barriers exist that limit the ability to complete a connection.
  4. Walking and cycling should be a convenient option for movement within the network in terms of safety and efficiency.
  5. Residential streets should provide access to residential property.
  6. Collector streets should provide access to small commercial areas and community amenities, such as schools, parks, and churches.
  7. Collector streets should provide access from residential streets to arterials and to commercial areas.
  8. Place-focused streets should incorporate frequent intersections and short block lengths to make travel routes more efficient and improve walkability.
  9. The street network created by collector and residential streets should balance efficient travel with appropriate speeds.
  10. Connections should be assigned within a network in conjunction with an overall connectivity strategy, rather than just to link ad-hoc elements of subdivisions.
  11. Bicycle accommodations should be provided in accordance with the City's Parks, Recreation, Open Space, Trails, and Streetscape Visioning Master Plan.
  12. Streets should follow natural features, such as creek beds and topography, as appropriate.
  13. Streets should preserve or create view sheds to natural features, amenities, landmark buildings, or other important features.
- 2.6.D. Mutual Access Easement – Properties along arterials and frontage roads are required to provide a minimum 24-foot mutual access easement across the property to adjacent properties with appropriate intersection flares. Mutual access easement may be required for other roadway sections and developments based on area and site circulation patterns. Larger tracts of land shall be divided along TxDOT frontage in a manner to provide access to all tracts by means of a dedicated ROW or mutual

access easement in order to not landlock any property that would meet TxDOT driveway spacing requirements.

- 2.6.E. Minimum Access Points – A minimum of two planned points of public ingress and egress are required to facilitate emergency vehicle access and to distribute traffic through the development as determined by the Fire Marshal and the Director of Engineering.
- 2.6.F. Grade Separations – When a grade-separation intersection is shown in the Thoroughfare Master Plan, and its construction will be at an uncertain time in the future, all property which is needed in excess of that required for constructing the intersection at grade shall be reserved.
- 2.6.G. High Volume Drive Thru Requirements – The Director of Engineering may increase the amount of stacking spaces required on site based on the proposed development use. Proposed retail uses and drive thrus with historically high traffic volumes may have additional requirements to prevent congestion and backing up on the adjacent thoroughfare
- 2.6.H. School Access Criteria and Locational Criteria

The location of a school facility (daycare, Montessori school, private school, charter school, or public school) has a huge impact on adjacent land uses and mobility, and as potential sites are evaluated for future facilities, multiple factors should be considered. Early designation of school sites helps to ensure adequate access and traffic circulation as well as minimizing development costs. The following criteria are intended to assist City officials, staff, and developers in the provision of proper site locations for these facilities during the development process. Developers are encouraged to discuss with the school district where a proposed project is to be located, prior to submittal, to determine district need of a potential facility as well as best placement within the development.

If requested, a traffic circulation study shall be provided. This study shall include the estimated maximum peak hour trip generation of the facility, the planned circulation of inbound and outbound traffic during drop-off and pick-up operations, and the estimated length of the queue of cars waiting to pick up students.

Right turn lanes will be required at all driveways. Based on the site design, storage lengths greater than the minimum values shown in **Table 2-5** may be required.

1. Elementary Schools:

- a. Elementary school sites shall not be located adjacent to major thoroughfares;
- b. Each school site shall have a minimum of two points of public access;
- c. Sites should be located at the intersection of two collector streets to enhance both pedestrian and vehicular traffic circulation;

- d. The design of the site and the circulation/parking plan shall ensure that school traffic does not back up onto any public street;
  - e. Sites shall not be located next to alleys that would back to the sides of the school site. This discourages student foot traffic in alleyways;
  - f. Sites should be located in close proximity to storm drainage, water, and sanitary sewer connections; and,
  - g. Sites should have topography that maximizes land utilization and safety, and minimizes development costs.
2. Middle Schools:
- a. Middle school sites should be located at arterial and collector intersections with the exception of principal arterials;
  - b. Each school site shall have a minimum of two points of public access and separate bus access;
  - c. Sites should be designed to encourage and enhance both pedestrian and vehicular traffic circulation;
  - d. The design of the site and the circulation/parking plan shall ensure that school traffic does not back up onto any public street;
  - e. Sites shall not be located next to alleys that would back to the sides of the school site. This discourages student foot traffic in alleyways;
  - f. Sites should be located in close proximity to storm drainage, water, and sanitary sewer connections; and,
  - g. Sites should have topography that maximizes land utilization and safety, and minimizes development costs.
3. High Schools:
- a. High school sites should be located adjacent to an arterial intersection with a collector/arterial with the exception of principal arterials;
  - b. Each school site shall have a minimum of two points of public access and separate bus access;
  - c. Sites should be designed to encourage and enhance both pedestrian and vehicular traffic circulation;
  - d. The design of the site and the circulation/parking plan shall ensure that school traffic does not back up onto any public street;
  - e. Sites shall not be located next to alleys that would back to the sides of the school site. This discourages student foot traffic in alleyways;

- f. Sites should be located in close proximity to storm drainage, water, and sanitary sewer connections; and,
- g. Sites should have topography that maximizes land utilization and safety, and minimizes development costs.

## **2.7. Driveways**

### **2.7.A. Driveway Types**

1. A residential driveway provides access to a single-family residence, duplex, or multi-family building containing three or fewer dwelling units. For lots 50 feet or greater in width, residential driveways shall access only residential streets or alleys. For lots less than 50 feet in width, residential driveways shall access only alleys. Residential driveways shall not access collectors or arterials. Residential driveways shall have a minimum length of 20 feet measured from the street/alley right-of-way line or pedestrian easement, whichever is closer, to the face of building.
2. A commercial driveway provides access to office, retail, institution, or a multi-family building having more than three dwelling units. Industrial plant driveways which serve administrative or employee parking lots shall be considered commercial driveways. Commercial drives shall access arterial or collector streets only.
3. An industrial driveway serves truck movements to and from loading areas of the industrial, warehouse, or truck terminals. A community of regional shopping center may have one or more driveway specially designed and located to provide access for trucks. Industrial drives shall access arterial or collector streets only.

### **2.7.B. Driveway Widths – The width of a driveway refers to the width of pavement at the ends of the interior curb returns. The full drive width and access pavement to the property built for the development shall be constructed with the initial project.**

1. All residential drives shall have a minimum width of 11 feet and a maximum width of 20 feet for drives onto streets and 30 feet for drives onto alleys. Joint access residential drives shall have no less than 9 feet on each property.
2. Commercial drives shall have a minimum width of 24 feet and a maximum width of 40 feet.
3. Industrial drives shall have a minimum width of 36 feet and a maximum width of 40 feet.
4. Commercial and industrial drives located at existing or future median openings shall have a minimum width of 36 feet to allow for separate exit lanes for left and right turns. Additional lanes may be required by the Director of Engineering based on existing or planned signalization of a driveway or based on the findings of a Traffic Impact Analysis.

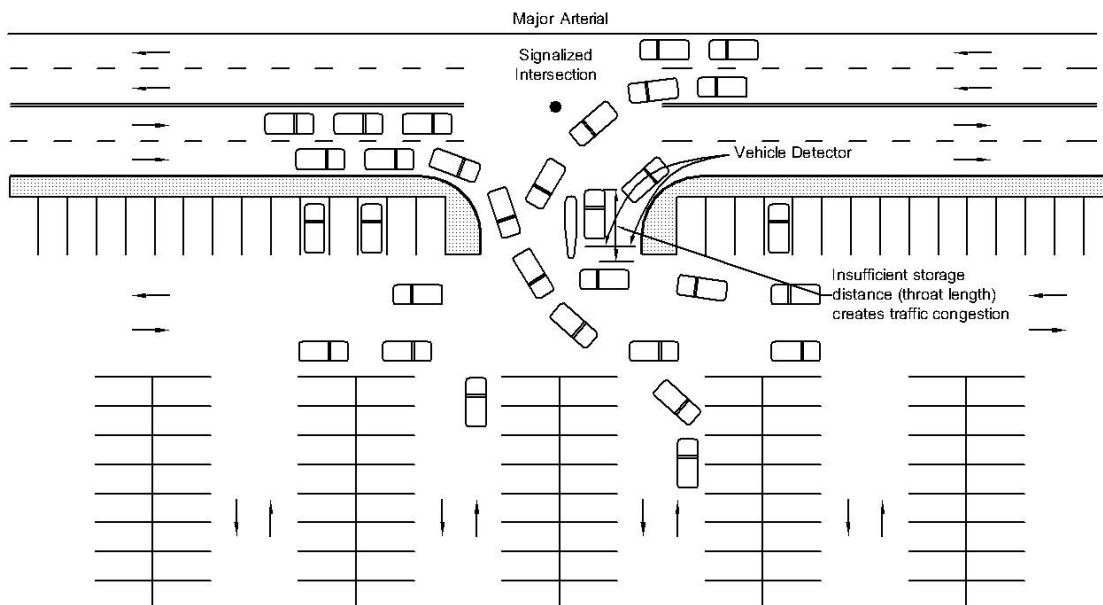


5. Commercial and industrial drives with one-way operation shall have a width of 24 feet for both ingress and egress lanes. The egress lane width may be reduced to 20 feet at right-in, right-out locations. The ingress lane width may be reduced to 20' if no callbox or equivalent access control device is present. The separation median width shall be a minimum of 4 feet and a maximum of 10 feet.
  6. All driveways intersecting dedicated streets shall be built with a circular curb radius connecting the 6-inch raised curb of the roadway to the design width pavement of the driveway. Driveway radii shall begin at the street curb, end as a projection of the property line, and fall entirely within the subject property.
    - a. The curb radii for a residential drive shall be 5 feet.
    - b. The curb radii for a commercial drive shall be 30 feet.
    - c. The curb radii for an industrial drive shall be 30 feet.
    - d. In order to maintain the location of the edge of the pavement for the roadway, driveway radii shall be designed to become tangent to the street curb line. Drainage inlets shall maintain a minimum 10-foot clearance on upstream side and 5-foot clearance on downstream side from all drive radii.
    - e. Encroachment of commercial or industrial drives shall not occur on an adjacent property without a mutual access easement being executed between both property owners. Driveway vertical grade requirements shall be as shown in **Tables 2-8** and **2-9**.
- 2.7.C. Throat Length – length of driveway as measured from the street curb line to the curb line of the first on-site intersection, driveway, or parking stall.
1. Driveway throat length is important for safe and efficient traffic operation on the site and the adjacent roadway. The driveway throat needs to be sufficient length so that the vehicles may enter, exit, and circulate on the site without interference with each other or with through traffic on the adjacent roadway.
  2. Inadequate throat length creates a complex pattern of closely spaced and confusing vehicle conflicts as illustrated in **Figures 2-13** and **2-14**. Where parking maneuvers block the driveway and prevent vehicles from entering or exiting the site, the propensity of accidents significantly increases and traffic flow diminishes.
  3. Throat length and driveway length are interrelated. A wider driveway cross section requires a longer throat length due to weaving maneuvers. In addition, the need to achieve high exit flow rates becomes more important as the exit drive's volume increases. Exiting conditions control the throat length for large traffic generators due to vehicle queuing and the need to find adequate gap in traffic on the adjacent roadway. Conversely, entry conditions control throat length of smaller traffic generators due to slower vehicle speeds created by fewer on site circulation and parking opportunities.

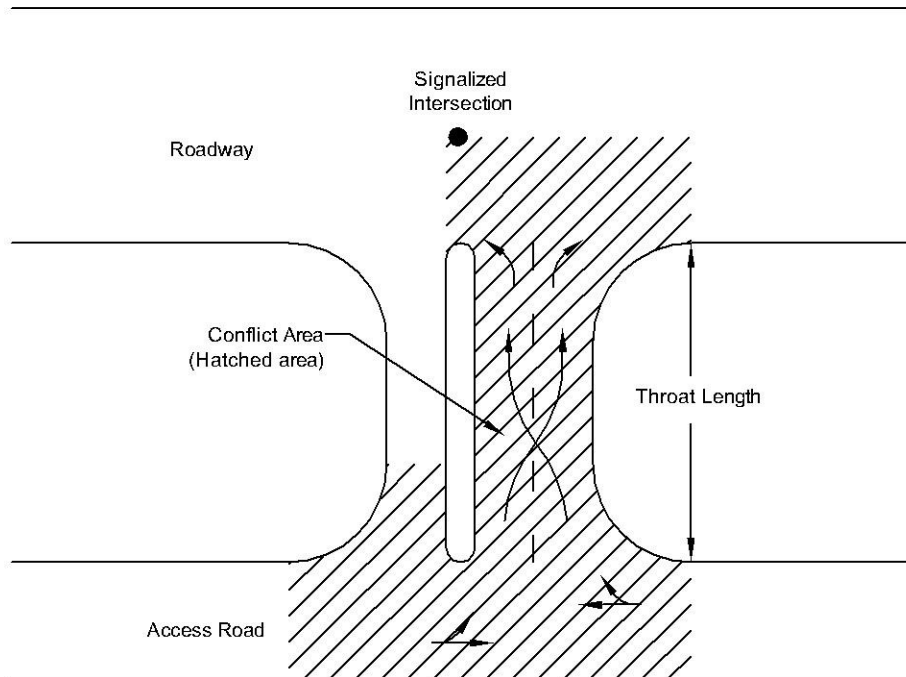
4. In order to determine the necessary throat length for all development driveways (minimum total storage) the sum of all driveway throat length shall equal the number of vehicles expected to accumulate in the driveways during an average peak period. Traffic volumes should be assigned to the applicable driveways and the highest lane volume should be accommodated. In the absence of adequate traffic volume and trip generation data, the minimum throat length from **Table 2-6** shall be used. **Table 2-6** was derived from the 2015 edition of the Transportation Research Board's Access Management Manual.

**Table 2-6 – Minimum Driveway Throat Length for Number of Exit Lanes**

Number of Exit Lanes	Minimum Throat Length (feet)
1	60
2	75
3	200
4	300



**Figure 2-13 – Insufficient Driveway Throat Length**



**Figure 2-14 – Capacity Limited by Throat Length and Weaving Area**

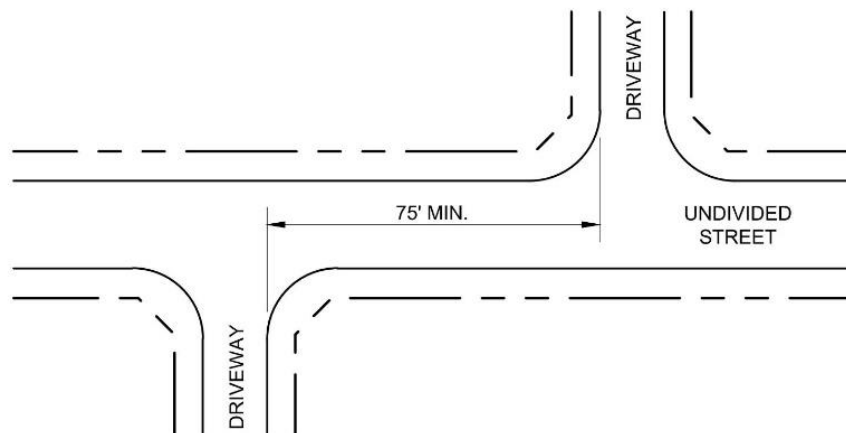
2.7.D. Driveway Spacing and Location in Relation to Other Streets and Drives

1. Unsignalized driveways introduce conflicts and friction into the traffic stream. As an area develops and traffic volumes on the adjacent roadways grow, the gaps between vehicles are shorter. Vehicles turning from a through lane cause through vehicles to slow, causing “shock waves” to the vehicles on the roadway network. In order to maintain the capacity of the roadway network, driveway access should be limited.
  - a. Residential – Driveway approaches on a tract of land devoted to one use shall not occupy more than 70% of the frontage abutting the roadway. No more than two driveway approaches shall be permitted on any parcel of property on each street. These standards may be waived for cul-de-sac lots. Residential driveways on rural roads with roadside ditches shall not be spaced closer than 100 feet apart to accommodate driveway culverts. Where this cannot be accommodated, a shared access driveway shall be dedicated on an approved plat.
  - b. Commercial and Industrial – Spacing and location of driveways shall be related to existing driveways and those shown on approved development plans. The spacing between driveways shall depend upon the Thoroughfare Master Plan designation of the roadway per **Table 2-7**. Driveways shall not be permitted in the transition area of any right turn lane. A maximum of three driveways shall be permitted for each 1,000 feet of roadway frontage.

**Table 2-7 – Commercial and Industrial Driveway Spacing**

Thoroughfare Type	Minimum Drive Spacing (feet)
P6D	300
M6D, G6D, G4D, M4D	240
M4U, M3U	220
M3U-F	See current edition of TxDOT <i>Access Management Manual</i>
C2U, R2U	180

- c. Spacing between driveways shall be measured along property line from the closest edge of pavement from one driveway to the closest edge of pavement of the next driveway.
2. Driveway Offset Spacing in Relation to a Cross Street
    - a. Offset spacing between a driveway and the adjacent cross street intersection shall be measured along the ROW line from the cross street projected curb line to the projected curb line or edge of pavement of the driveway. The minimum offset difference shall be equal to the minimum spacing requirement as shown in **Table 2-7**. Residential driveway spacing from cross streets shall not be closer than 30 feet.
    - b. Non-residential and multi-family driveways on opposite sides of an undivided street shall align with each other or be spaced a minimum of 75 feet apart, measured edge to edge, to ensure that conflicting movements do not overlap. This spacing shall also apply to a driveway that is on the opposite side of an undivided street from an intersecting street. See **Figure 2-15**.



**Figure 2-15 – Driveway Spacing on Opposite Sides of an Undivided Street**

3. Driveway Spacing on Frontage Roads – Driveway spacing on all frontage roads shall be governed by TxDOT and shall meet minimum standards in accordance with the current edition of TxDOT Access Management Manual. Driveways located near entrance and exit ramps are strongly discouraged and shall be reviewed on a case-by-case basis. When allowed, design must meet minimum TxDOT standards.

#### 2.7.E. Driveway Grades

1. The change in grade between the roadway cross-slope and the slope of the driveway apron is important to ensure a smooth, low speed turning maneuver. The maximum algebraic change in grade is shown in **Table 2-8**. An abrupt change in grade will cause the front bumper to drag on surface of the street and driveway.

**Table 2-8 – Maximum Driveway Grade Change**

Thoroughfare Type	Algebraic Change (%)
P6D, M6D, G6D, G4D	5
M4D, M3U	6
M3U-F	See TxDOT current edition of <i>Roadway Design Guide</i>
M4U	7
C2U	10
R2U	12

2. The recommended lengths of vertical curve for the corresponding change in grade for driveway profiles are shown in **Table 2-9**.

**Table 2-9 – Vertical Curve Length for Driveways**

Change in Grade (%)	Length (feet)	
	Crest Curve	Sag Curve
< 6	5	6
6 to < 8	5	7
8 to <12	6	8

3. All driveway profiles should be designed to accommodate a sidewalk crossing at a maximum allowable cross-slope of 2% in order to meet ADA requirements.

## 2.8. Alley Design

Alleys are typically provided at the rear of residential lots for vehicular access to garages or other parking areas.

- 2.8.A. Alley Intersections – Alleys shall only intersect with a residential street. Alley intersection cannot be within 100 feet of an arterial roadway intersection. Alleys which run parallel to a major thoroughfare shall turn away from the major street not less than one subdivision lot width or a minimum of 50 feet (whichever is greater) from the cross street intersection. Where this occurs, a 5-foot common area shall be provided adjacent to the ROW. Four-way alley intersections are not permitted.
- 2.8.B. Alley Radius – Alley radii at street intersections shall conform to City Construction Details and not be less than 10 feet.
- 2.8.C. Alley Width – The minimum width of the alley ROW shall be 17 feet, and the minimum pavement width shall be 12 feet.
- 2.8.D. Turnouts – Alley turnouts shall be paved to the property line and shall be flared per the City of McKinney Standard Detail. Paving radii where alleys intersect streets shall be 17 feet and shall be 12 feet at intersections with all other streets.
- 2.8.E. Intersections – Alley intersections and sudden changes in alignment shall be avoided. Lot corners shall be cut off at least 10 feet on each tangent to permit sight distance and safe vehicular movement.
- 2.8.F. Dead-End Alleys – Dead-end alleys shall not be allowed.
- 2.8.G. Obstructions – All alley ROW shall be kept free and clear of obstructions.
- 2.8.H. Outlet – Maximum alley length of 600 feet without an outlet.
- 2.8.I. Alleys shall be designed in accordance with **Figure 2-16, Table 2-1**, and the City of McKinney Construction Standard Details.

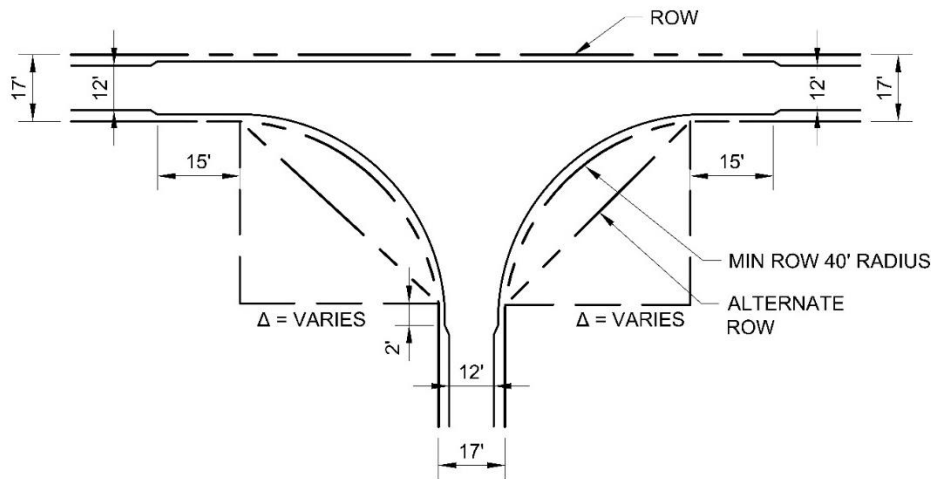


Figure 2-16 – Typical Alley Layout

## 2.9. Traffic Control

2.9.A. Permanent Traffic Control – Permanent Traffic Control devices such as street signs, pavement markings, barricades, and traffic signals are used to manage traffic flow and maintain safe and efficient streets throughout the City. General requirements for traffic control devices in the City of McKinney are described in the following sections. Refer to the current edition of the *TMUTCD* for additional information and guidance. Refer to the Approved Materials List in the City of McKinney Construction Standard Details.

1. Street Signs – Signs should be used only where justified by engineering judgment and demonstrated in a Traffic Engineering Study that indicates the location of necessary signs. All signing plans shall be reviewed and approved by the Director of Engineering, and be designed in accordance with the principles described in the current edition of the *TMUTCD*.
2. Pavement Markings – Pavement Markings provide guidance and information to roadway users and include items such as: striping, colored pavement, delineators, islands, and channelizing devices. The following markings are required per street classification.
  - a. Arterials
    - i. Centerline stripe for undivided sections;
    - ii. Lane lines;
    - iii. Turn lanes;
    - iv. Delineators for roadside obstructions;
    - v. Raised Pavement Markers; and,

- vi. Edge lines (for non-curbed streets and bridges where width is 20 feet or more).
  - b. Collectors
    - i. Centerline stripe (where width is greater than 20 feet or more and ADT more than 4,000 vpd); and,
    - ii. Lane lines and edge lines (for non-curbed streets where width is 20 feet or more and ADT more than 3,000 vpd).
  - c. All pavement markings shall be thermoplastic and shall meet the requirements of the TMUTCD. Refer to the City of McKinney Construction Standard Details for specific guidance on roadway marking standards and approved manufacturers.
3. Traffic Signal Spacing – Signals shall only be installed at warranted and justified locations as approved by the Director of Engineering. The minimum distance between signalized intersections of arterial and/or collector streets shall be 1,200 feet.



### 2.9.B. Temporary Traffic Control

1. When the normal function of the roadway is suspended through closure of any portion of the ROW, temporary construction work zone traffic control devices shall be installed to effectively guide the motoring public through the area. Consideration for roadway user safety, worker safety, and the efficiency of roadway user flow is an integral element of every traffic control zone.
2. Traffic control plans shall be site-specific and included within all roadway construction plans as determined by the Director of Engineering. Within City and County jurisdictions, all traffic control plans shall be prepared and submitted in accordance with the standards identified in Part VI: Highway Traffic Signals of the current edition of the *TMUTCD*. Within TxDOT jurisdiction, all traffic control plans shall be prepared and submitted in accordance with TxDOT standards. Lane closures will not occur on arterial roadways without an approved traffic control plan. Temporary traffic control shall be in accordance with the current TxDOT BC, WZ, and TCP standards, or as approved by the Director of Engineering.
3. All traffic control plans must be prepared by an individual that is certified in their preparation. This certification can be achieved through approved organizations such as the International Municipal Signal Association (IMSA), the American Traffic Safety Services Association (ATSSA), or by a Professional Engineer licensed in the State of Texas. All traffic control plans and copies of work zone certification must be submitted for review and approval a minimum of seven working days prior to the anticipated lane closure.
4. Lane closures require approval from the Director of Engineering. Any such requests shall indicate anticipated duration of lane closure. Approval of plans may require additional SUE investigations to identify conflicts and minimize lane closures times, as determined by the Director of Engineering. Additional conditions may be determined by the Director of Engineering depending on factors including, but not limited to, closure duration, traffic volume, proximity to major traffic generators, and availability of alternate routes.

### 2.9.C. Neighborhood Traffic Management

1. The intent is to produce a roadway network within which traffic is dispersed and slowed naturally. The result is potentially narrower street cross sections and shorter access trips to the regional roadway network, leaving drivers less inclined to speed.
2. Traffic calming measures shall be incorporated into the design of residential developments unless a Traffic Engineering Study concludes that traffic calming measures are not necessary. Traffic calming measures may alter standard City lane widths and cross sections as approved by the Director of Engineering. A Traffic Engineering Study may be waived with the approval of the Director of Engineering. All traffic calming devices must be approved by the Director of Engineering and the Fire Marshal.

## 2.10. Pedestrian Facilities

2.10.A. All pedestrian facilities must conform to the following current requirements and shall be in accordance with the City's Parks, Recreation, Open Space, Trails, and Streetscape Visioning Master Plan.

2.10.B. Pedestrian Design Guidelines include the current edition of the following:

1. Texas Accessibility Standards (TAS);
2. Americans with Disabilities Act (ADA) Standards;
3. Public Right-of-Way Accessibility Guidelines (PROWAG); and,
4. Texas Manual on Uniform Traffic Control Devices (TMUTCD).

2.10.C. Hike and Bike Routes – To create a network of trails and sidewalks, the Hike and Bike Master Plan specifies a network of enhanced sidewalks and spine trails throughout the City. Refer to the Hike and Bike Master Plan for the location of these improvements. The placement and location of these enhanced sidewalks shall be determined by the Director of Engineering. Additional ROW and easements may be needed to accommodate these improvements. Consideration shall also be given to North Central Texas Council of Government (NCTCOG) Regional Paths (Trails) and Bikeways master plans.

### 2.10.D. Sidewalks

1. The purpose of the public sidewalk is to provide a safe area for pedestrians. City of McKinney policy provides that sidewalks are to be constructed with the paving of streets or building construction unless deferred by the Director of Engineering. Sidewalks constructed as part of a new development or re-development are considered public facilities and shall be constructed according to the requirements outlined in this section.
2. A sidewalk is the paved area in a street ROW between the curb lines or the edge of pavement of the roadway and the adjacent property lines for the use of pedestrians. The City of McKinney considers a sidewalk to be an "accessible route" as specified in Section 4.3 of the Texas Accessibility Standards (TAS) and considers a public sidewalk a "facility" under the TAS and the U.S. Department of Justice Americans with Disabilities Act (ADA) regulations at 28 C.F.R. Part 35. Sidewalks are subject to the requirements of Chapter 469 of the Texas Government Code as a City-funded public ROW project for Texas Department of Licensing and Registration (TDLR) inspection purposes (per 16 Texas Administrative Code, Chapter 68) unless exempted by the Director or Engineering.
3. Concrete sidewalks designed and located according to City standards shall be constructed along both sides of all streets, per the City of McKinney Unified Development Code.

4. All new sidewalks in the City of McKinney shall be placed 1 foot inside the ROW line.
5. Meandering sidewalks shall have a minimum 200 foot radius. Meandering sidewalks shall be within a minimum 5 feet and a maximum 40 feet behind back of curb.
6. The maximum running grade (longitudinal slope) of the sidewalk shall not exceed 5%. The maximum cross-fall (cross-slope) of the sidewalk shall not exceed 2%.
7. Sidewalk widths vary depending on the roadway classification. The sidewalk width shall be equal to the requirement as shown in **Table 2-1**. The sidewalks shall be located within the street ROW unless pre-existing physical encroachments (e.g., utility infrastructure or trees) dictate otherwise. Sidewalks may be allowed in landscape areas and pedestrian access easements with the approval of the Director of Engineering. Sidewalks and parkways (curb to ROW) shall be graded at 2% above the top of the street curb.
  - a. Areas with Screening Walls – In areas where a screening wall is provided, a sidewalk shall be provided and shall not encroach closer than 18 inches to the wall.
  - b. Sidewalks on Bridges – All street bridges shall have a sidewalk constructed on each side of the bridge. The sidewalk shall be a minimum of 6 feet wide with a parapet wall providing a minimum of 2 feet behind the curb of the roadway. A standard pedestrian bridge rail protecting the sidewalk shall be provided on the outside edge of the bridge. Refer to **Section 6.5.E** for additional railing requirements on bridges.
  - c. Sidewalks Under Bridges – When new bridges are built as a part of the construction of a divided arterial roadway or the reconstruction of a divided arterial roadway and a pedestrian crossing for a hike and bike trail is needed, a 12-foot sidewalk will be built as a part of the embankment design underneath the bridge structure. The bridge structure should provide a minimum clearance of 10 feet above the sidewalk for pedestrian access.
  - d. Sidewalks on Culverts – All culvert crossings shall have a sidewalk constructed across and on each side of the culvert. The sidewalk shall be designed with a pedestrian handrail, designed and constructed in accordance with the Pedestrian Design Guidelines outlined above. In some situations, combination rails or parapet walls may be required.
  - e. Construction of Sidewalks – Non-residential and multi-family sidewalks, ramps, and landing areas shall be built at the time of lot development. Sidewalks, ramps, and landing areas in residential areas shall be installed along all roadways and common areas prior to final acceptance. Existing public sidewalks not compliant with current ADA standards shall be reconstructed with new development or the re-development of an existing lot.

- f. Temporary Sidewalks
  - i. Pedestrians are required to be accommodated during time of construction. If the construction zone affects the movement of pedestrians, adequate pedestrian access and walkways meeting ADA requirements shall be provided. All Pedestrian Accommodation Plans shall be reviewed and approved by the Director of Engineering, and be in accordance with the principles described in the Pedestrian Design Guidelines outlined above.
  - ii. Temporary Sidewalks may be constructed with materials other than concrete. The material shall be approved by the Director of Engineering and be an all-weather material of a color and texture distinctly different from the sidewalk and specified on the site plan. Where developments occur within 0.5 miles of a school site, temporary sidewalks must be constructed connecting the development to the school site. The route shall be approved by the Director of Engineering.
- g. Access to Cul-de-Sacs from Adjacent Streets – When a cul-de-sac ROW abuts the ROW of another thoroughfare, a minimum 5-foot wide sidewalk shall be provided between the cul-de-sac and adjacent street. All screening and/or fencing requirements shall be met in addition to this requirement.

#### 2.10.E. Barrier Free Ramps

- 1. Accessible ramps for sidewalk crossings at intersections of all streets and thoroughfares and at all driveways shall conform to the Pedestrian Design Guidelines and shall be constructed in a manner to be easily and safely negotiated by the physically disabled. Accessible ramp details shall be subject to approval by the Director of Engineering.

#### 2.10.F. Pedestrian Handrails

- 1. Pedestrian handrail of a height not less than 42 inches shall be required when any of the following conditions are located within 5 feet of an existing or planned public sidewalk, or as directed by the Director of Engineering:
  - a. A permanent or intermittent body of water;
  - b. Top of slope steeper than 6H:1V with drop-off ending at a body of water;
  - c. Top of slope steeper than 3H:1V with drop-off greater than 2.5 feet; or,
  - d. Vertical surface with drop-off greater than 2.5 feet.
- 2. Pedestrian handrails are a long-term maintenance liability and may be considered a roadside hazard and/or a general aesthetic nuisance. To minimize these impacts, the conditions that invoke the requirement for a pedestrian handrail shall first be reviewed for alteration to remove the hazard. If no alteration is feasible, then a pedestrian handrail shall be constructed.

3. Exemptions to this requirement may be considered by the Director of Engineering when:
  - a. The depth of a body of water is less than 1 foot;
  - b. The sidewalk provides recreational access to a body of water;
  - c. The handrail would irreversibly spoil the natural landscape; or,
  - d. Alternative means of protection are approved.
4. Pedestrian handrails located on public sidewalks shall be TxDOT Type C or E rails, constructed in accordance with the current PRD standard (the grip rail may be eliminated unless required by the Pedestrian Design Guidelines), or as approved by the Director of Engineering. Any required concrete foundation shall be in addition to the minimum sidewalk width. All rail surfaces shall be painted with industrial-grade exterior paint, with the color approved by the Director of Engineering.

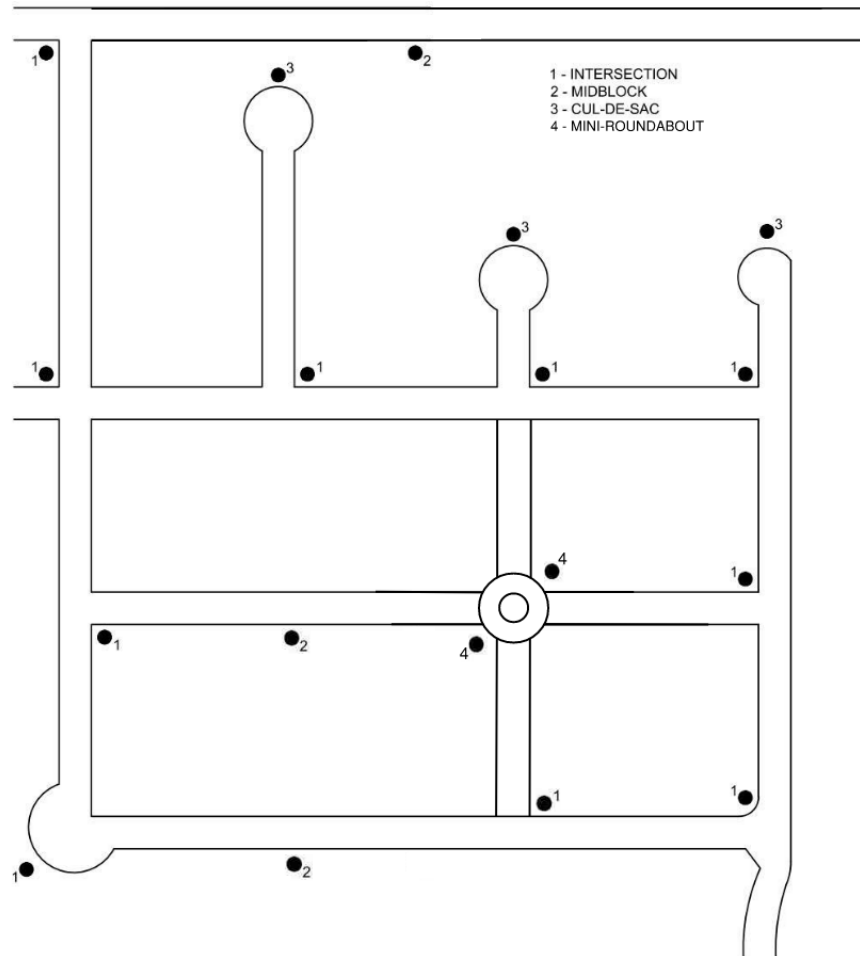
## **2.11. Street and Roadway Lighting**

### **2.11.A. General**

1. Street lighting refers to lighting systems installed within residential subdivisions and along collector roadways. These lighting systems are designed to provide safety lighting at intersections, roadside hazards, geometric changes, and other areas.
2. Roadway lighting refers to lighting systems installed continuously along highways, frontage roads, and arterials.
3. Site lighting of private businesses, residential properties, etc. is not included in the requirements of this section.
4. Illumination of highways, tollways, and other facilities outside of City of McKinney ROW is subject to the design requirements of the applicable agency, and is not included in the requirements of this section.
5. All street lighting and roadway lighting systems within the City of McKinney shall utilize only full-cutoff luminaires.
6. All street lighting and roadway lighting systems shall be designed in accordance with Chapter 425 of the Texas Health and Safety Code regardless of the source of funds utilized for construction and/or maintenance of said lighting system.
7. Use the illuminance method for performing photometric calculations. A maintenance factor of 0.80 shall be utilized.

### 2.11.B. Residential and Collector Street Lighting

1. All street lighting assemblies shall be placed within the ROW.
2. No street lights shall be installed in alleys or for alley intersections with residential roadways.
3. All residential and collector street lighting systems within the City of McKinney are owned and operated by the utility provider serving the development. Luminaire and pole combinations are subject to the requirements of the applicable utility provider.
4. No signage or ornamental attachments shall be installed on street lighting assemblies. Ornamental poles, luminaires, and appurtenances may be permitted with approval by the Director of Engineering.
5. Street lighting assemblies shall be placed to avoid blocking visibility of traffic control devices. In all cases, street lighting assemblies should be placed on the downstream end of the radius, just beyond the limit of the theoretical crosswalk. Street lighting assemblies should be located on the opposite side of the intersection from the name blades. Refer to the City of McKinney Construction Standard Details for additional information.
6. Typical residential street lighting system layout should be as shown in **Figure 2-17**. Exceptions to the typical layout are permissible where site conditions dictate alternate placement of street lighting assemblies, subject to approval by the Director of Engineering. Examples of these conditions include but are not limited to retaining walls, officially protected trees, wide medians, and non-correctable sight distance obstructions.



**Figure 2-17 – Typical Residential Street Lighting System Layout**

7. Typical street lighting system layout along collector roadways shall adhere to the minimum and maximum pole spacing values provided in this section. Luminaires shall be placed at all intersections, crosswalks, and trail crossings.

8. Street light spacing along collectors and residential roadways shall be as follows:

Residential:	Minimum spacing:	450 feet
	Maximum spacing:	900 feet
Collector:	Minimum spacing:	300 feet
	Maximum spacing:	600 feet

9. Where lighting assemblies are placed at intersections, spacing distances between lighting assemblies shall be measured from the center of the intersections, not the physical distance from pole to pole.

10. Private or other lighting outside the ROW shall not be considered a substitute for lighting under this section.

2.11.C. Continuous Arterial Roadway Lighting

1. Design values for continuous arterial roadway lighting shall be as shown in **Table 2-10**.

**Table 2-10 – Photometric Design Criteria**

Roadway Type	Average Maintained Illuminance (HFC)	Uniformity Ratios	
		Maximum : Minimum	Average : Minimum
Arterial – Principal	1.1	10:1	3:1
Arterial – Major	1.1	10:1	3:1
Arterial – Greenway	0.9	10:1	4:1
Arterial – Minor	0.8	10:1	4:1

2. Mounting height for street lighting fixtures is the vertical distance from the roadway surface at the edge of the travel lane to the light source, regardless of lateral placement of the pole.
3. Pole setback is the horizontal distance from the edge of the travel lane to the pole.
4. Existing continuous arterial lighting within the City of McKinney may be owned and maintained by either the City of McKinney or a utility provider, depending on the location. Contact the City of McKinney Traffic Engineering Department to determine which design standards are applicable based on ownership and maintenance responsibilities. Utility provider design standards and requirements shall be considered during the design process, when applicable.
5. Typical pole spacing for arterial lighting shall be developed by the Engineer in accordance with the above photometric criteria. Photometric calculations for each project shall be submitted to the Engineering Department for approval.
6. Pole spacing near signalized intersections shall take into account the presence or lack of luminaires on the traffic signal poles.
7. Street light poles located in the median should maintain a minimum spacing of 30 feet from the center of the median nose.
8. Light contribution from lighting systems outside the ROW shall not be considered in the photometric design of continuous arterial lighting systems.
9. Refer to City of McKinney Construction Standard Details for arterial lighting electrical service standards.



2.11.D. Roundabout Lighting

1. Lighting assemblies shall be placed along the outside of the roundabout. No street light poles shall be installed in the central island. Architectural or landscape lighting may be installed in the central island with the approval of the Director of Engineering.
2. Lighting of roundabouts shall be designed to emphasize the splitter islands to the greatest extent practicable.
3. No less than one light pole per roundabout approach shall be installed.
4. The requirements included in this section for roundabouts do not apply to mini-roundabouts. Refer to residential street lighting requirements for layout of street lights at mini-roundabouts.

2.11.E. Luminaires and Light Sources

1. The following light sources are permitted for street and roadway lighting purposes:
  - a. LED (4K preferred for arterial roadways, 3K preferred for residential and collector roadways)
2. Maximum single fixture wattage shall be 400W or equivalent.
3. Maximum luminaire mounting height shall be 45 feet.
4. Minimum luminaire mounting heights shall comply with **Table 2-11**.

**Table 2-11 – Mounting Height Restrictions**

Light Source	Wattage*	Minimum Mounting Height (feet)
LED 3K-4K	100	18
	150	20
	250	30
	400	40

\*Equivalent wattage for LED fixtures.

5. Luminaires and light sources should be selected to achieve photometric needs with an emphasis on energy efficiency.
6. Refer to the applicable utility provider’s standards and requirements for lighting systems to be owned and operated by utility companies.

7. Use of non-standard luminaires within utility-owned and operated systems is additionally subject to the approval of the applicable utility owner.

#### 2.11.F. Pole Requirements

1. All roadway and street lighting poles shall be of a breakaway design in accordance with AASHTO's current edition of *Standard Specifications for Structural Supports for Highway Signs, Luminaires, and Traffic Signals*, unless otherwise approved by the Director of Engineering.
2. All new roadway lightings that are City-owned and maintained along arterial streets shall follow the pole standards as depicted in the City of McKinney Construction Standard Detail 7004M or approved equivalent. All new lightings along arterial streets that are owned and maintained by a utility provider shall follow the details provided by the responsible utility provider.
3. Decorative, painted, or other special light poles shall be permitted subject to special provisions and requirements as prescribed by the Director of Engineering.
4. Maintenance of non-standard light poles within a City-owned and operated system shall be funded through a cost-sharing agreement to be developed for each specific project and/or development. Use of non-standard lighting assemblies for utility-owned and operated systems is additionally subject to the approval of the applicable utility owner.
5. Refer to the applicable utility provider's standards and requirements for lighting systems to be owned and operated by utility companies.

#### 2.12. Conduit Systems

- 2.12.A. Conduit systems shall be installed for future irrigation, traffic signals, communications, and arterial roadway lighting. Refer to the City of McKinney Construction Standard Details for additional information.
- 2.12.B. Traffic signal conduit and ground boxes for future traffic signals shall be installed at all arterial-arterial and arterial-major collector intersections, the traffic signal conduit systems shall consist of one – 4-inch schedule 40 PVC pipe in accordance with the City of McKinney Construction Standard Details prior to pavement construction.
- 2.12.C. All divided arterial roadways constructed in the City of McKinney shall be built with a conduit system in the median. The conduit system shall be used for traffic signal communications and street lighting. The traffic signal communications conduit systems will consist of two each – 3-inch schedule 40 PVC pipes in accordance with the City of McKinney Construction Standard Details.
- 2.12.D. Roadway lighting conduit systems will consist of one – 2-inch schedule 40 PVC pipes in accordance with the City of McKinney Construction Standard Details. Conduit system design requirements may vary based on the electric provider.

Engineer should consult with the Engineering Department prior to performing design of these systems.

2.12.E. Median conduit system locations shall be in accordance with the City of McKinney Construction Standard Details. Conduit systems shall be located away from median centerline in areas planned for trees or landscaping. All conduit plans shall be reviewed and approved by the Director of Engineering.

2.12.F. Conduit systems for residential street lighting systems are typically designed and installed by the electric provider and are not described in this manual.

2.12.G. Maximum conduit length between any two ground boxes shall be 500 feet.

### 2.13. Traffic Impact Analysis

2.13.A. The purpose of a Traffic Impact Analysis (TIA) is to assess the effects of specific development activity on the existing and planned roadway system. It is the intent of this section to make traffic access planning an integral part of the development process.

2.13.B. For the purposes of analysis and design, the thoroughfare network for the City of McKinney is based on operational values of Level of Service D or better as a criterion for design purpose. Level of Service D is the industry standard and balances vehicle movement, impact on neighborhoods, and costs.

2.13.C. When a Traffic Impact Analysis is required:

1. A TIA will be required at the time of platting land for developments that are expected to meet a threshold level of change as described below. The City reserves the right to require a TIA for land developments that do not meet the threshold requirements, but may impact a sensitive area with traffic issues or may be a known public concern.
  - a. More than 100 Peak Hour Trip (PHT) generation
  - b. More than 5,000 vehicle trips per day generation
  - c. More than 100 acres of property is involved
2. Any changes or alterations to the Thoroughfare Master Plan
3. A TIA shall be required when there is a request to amend the Thoroughfare Master Plan.
4. A TIA will be required for all developments that are adjacent to and take access from TxDOT roadways.
5. A TIA that is required of the applicant by the Engineering Department is part of the development review and approval process.

6. The TIA must be signed and sealed by a Professional Engineer licensed in the State of Texas with experience in Transportation Engineering sufficient to assess traffic impacts.
  7. The City of McKinney's Engineering Department must review and approve all TIAs before final acceptance. After acceptance of the TIA, the construction plan review process will determine further actions.
- 2.13.D. Traffic Impact Analysis Requirements – At a minimum, the TIA shall include the following items:
1. Traffic Analysis Map including:
    - a. Land Use, Site, and Study Area Boundaries, as defined.
    - b. Existing and Proposed Site Uses.
    - c. For TIAs where land use is the basis for estimating projected traffic volumes, Existing and Proposed Land Uses on both sides of boundary streets for all parcels within the study area.
    - d. All major driveways and intersecting streets adjacent to the property will be illustrated in sufficient detail to serve the purposes of illustrating traffic function. This may include showing lane widths, traffic islands, curbs, traffic control devices (traffic signs, signals, and pavement markings), and a general description of the existing pavement condition.
  2. Trip Generation and Design Hour Volumes Summary Tables
    - a. A trip generation summary table listing each type of land use, the building size assumed, average trip generation rates used (total daily traffic and A.M./P.M. peaks), and total trips generated shall be provided. For retail developments, weekend peak hour trip generation and analysis may be required.
    - b. Vehicular trip generation may be discounted in recognition of other reasonable and applicable modes, e.g., transit pedestrian, bicycles. When appropriate, pass-by trips can be modeled consistent with the current edition of ITE's *Trip Generation*. All such estimates shall be subject to the approval of the Director of Engineering.
    - c. Proposed trip generation calculations for single story commercial properties shall be based on a Floor-to-Area (building size to parcel size) ratio of 0.25 or more.
  3. Trip Distribution – The estimates for percentage distribution of trips by movements to/from the proposed development and through external intersections being analyzed. Figures shall be provided by Site Exits/Entrances.

4. Trip Assignment – The direction of approach of site-attracted traffic via the area’s street system.
5. Existing, Projected Build-Out, and Horizon Year Traffic Volumes – Figures shall be provided for each item. Existing traffic volumes are the numbers of vehicles on the streets of interest during the time periods listed below, immediately prior to the beginning of construction of the land development project. Existing traffic volumes shall be determined while schools are in session. Projected traffic volumes are the numbers of vehicles, including the build-out year.
  - a. Existing A.M. Peak Hour site traffic (including turning movements) if significant impact.
  - b. Existing P.M. Peak Hour site traffic (including turning movements).
  - c. Existing Weekend Peak Hour site traffic (including turning movements).
  - d. A.M. Peak hour total traffic including site-generated traffic and Projected Traffic (including turning movements).
  - e. P.M. Peak Hour total traffic including site-generated traffic and Projected Traffic (including turning movements).
  - f. For retail developments, Weekend Peak Hour total traffic including site-generated traffic and Projected Traffic (including turning movements).
  - g. For special situations where peak traffic typically occurs at non-traditional times, e.g., major sporting venues, entertainment venues, large specialty Christmas stores, etc., any other Peak Hour necessary for complete analysis (including turning movements).
  - h. Total daily existing traffic for street system in study area.
  - i. Total daily existing traffic for street system in study area and new site traffic and projected traffic from build-out of study area land uses.
6. Capacity Analysis
  - a. A capacity analysis shall be conducted for all public streets, intersections and junctions of major driveways with public streets, which are significantly impacted (as designated by the Director of Engineering), by the proposed development within the study area.
  - b. Engineer shall contact the City to request existing signal timings.
  - c. Capacity analysis shall follow the principles established in the current edition of the Transportation Research Board’s *Highway Capacity Manual*. Capacity will be reported in quantitative terms as expressed in the *Highway Capacity Manual* and in terms of traffic Level of Service.

- d. Capacity analysis shall include traffic queuing estimated for all critical applications where the length of queues is a design parameter, i.e. turn lanes and at traffic gates.

7. Conclusions and Requirements

- a. Engineer shall review the traffic layout and include recommendations related to traffic calming, connectivity to adjacent sites, pedestrian connectivity via sidewalks, sight distance at driveways and intersections, and capacities of the roadways in the network. Engineer shall identify potential overloading of roadways within the network.
- b. Roadways and intersections within the study area, that are expected to operate at Level of Service D, E, or F, under traffic conditions including projected traffic plus site-generated traffic must be identified. Viable recommendations must be made for raising the traffic conditions to Level of Service A, B, C, or D.
- c. Level of Service D is the design objective for all movements. Less than Level of Service D may be deemed acceptable for site and non-site traffic including existing traffic at build-out of the study area. The Director of Engineering must approve a Level of Service less than D.
- d. For phased construction projects, implementation of traffic improvements must be accomplished prior to the completion of the project phase for which the capacity analyses show that they are required. Plats for project phases subsequent to a phase for which traffic improvement is required may be approved only if the traffic improvements are completed or bonded.
- e. Voluntary efforts, beyond those herein required, to mitigate traffic impacts are encouraged as a means of providing enhanced traffic handling capabilities to users of the land development site as well as others.
- f. Traffic mitigation tools include, but are not limited to, pavement widening, turn lanes, median islands, access controls, curbs, sidewalks, traffic signalization, traffic signing, and pavement markings.
- g. The Director of Engineering may require items to be included in the TIA in addition to those listed above.

## **2.14. Gated Access Points**

- 2.14.A. Gated access points shall comply with this section, including those for private street subdivisions and for secure areas of multi-family, commercial, and industrial developments. Gated access points shall comply with the requirements of the International Fire Code, as amended by the City of McKinney, and separate permits shall be issued by the Fire Department prior to installation of any gated access point. No gate shall be permitted across or within a public right-of-way. All requirements of this section shall be included as a separate exhibit included with the plat for private street subdivisions or shall be shown on the site plan for multi-family, commercial, and industrial developments.
- 2.14.B. Gates shall not be located less than 150' from a public right-of-way unless a queuing analysis has been performed and approved by the Director of Engineering. A queuing analysis may be required for gates located more than 150' from a public right-of-way if very high traffic volumes or heavy truck traffic are anticipated, as determined by the Director of Engineering. The queuing analysis shall take into account the largest vehicle generally expected to use the gated access; passenger vehicles are generally acceptable for residential and commercial developments, but AASHTO WB-62 trucks shall be the minimum requirement for industrial developments. The queuing analysis shall take into account the location of any call boxes and/or card readers.
- 2.14.C. In no case shall a gate be located less than 60' from a public right-of-way for residential and commercial developments or less than 100' from a public right-of-way for industrial developments. In no case shall any call boxes and/or card readers be located less than 40' from a public right-of-way for residential and commercial developments or less than 80' from a public right-of-way for industrial developments.
- 2.14.D. Gated access points shall allow for u-turn movements when access is denied. For residential and commercial developments, the design vehicle shall be an AASHTO SU truck; for industrial developments, the design vehicle shall be a AASHTO WB-62 truck. Industrial developments shall consider stacking and idling of AASHTO WB-62 trucks waiting for access, unless stacking and idling are prohibited by required signage as stated on a site plan approved by the City of McKinney.
- 2.14.E. Gated access points shall provide a dedicated route for pedestrian access. Pedestrian access is not required for secure areas of commercial and industrial developments where access is provided to eligible employees and vendors through a public entrance to the building.

## SECTION 3 PAVEMENT AND SUBGRADE DESIGN REQUIREMENTS

### 3.1. General

3.1.A. The following specifies minimum standards required for the pavement and subgrade design for roadways and alleys within the City. These minimum standards are not intended to replace the professional judgment of the Geotechnical Engineer for any specific project. The standards may need to be expanded or modified on a case by case basis as determined necessary and appropriate by the Geotechnical Engineer, and as approved by the Director of Engineering in writing.

3.1.B. Pavement design life shall be 30 years.

3.1.C. **Table 3-1** lists the City's minimum pavement and subgrade thicknesses and dimensions. In no case shall the pavement and subgrade be less than the minimums.

**Table 3-1 – Pavement and Subgrade Minimum Standards**

Criteria	Thoroughfare Classification										
	P6D	M6D	G6D	G4D	M4D	M4U	M3U	M3U-F	C2U	R2U	RA
Concrete Thickness	9"	9"	9"	9"	8"	8"	8"	8"	*	6"	**
Lime Thickness	8"	8"	8"	8"	8"	8"	8"	8"	8"	6"	6"
Min. Lime Application Rate	8%	8%	8%	8%	8%	8%	8%	8%	6%	6%	6%
MC Depth											
<i>Avg. Swell &lt; 2%</i>	0-48"	0-48"	0-48"	0-48"	0-48"	0-48"	0-48"	0-48"	0-48"	0-48"	0-48"
<i>2% ≤ Avg. Swell &lt; 6%</i>	60"	60"	60"	60"	60"	60"	60"	60"	60"	60"	60"
<i>6% ≤ Avg. Swell &lt; 8%</i>	72"	72"	72"	72"	72"	72"	72"	72"	72"	72"	72"
<i>8% ≤ Avg. Swell &lt; 10%</i>	84"	84"	84"	84"	84"	84"	84"	84"	84"	84"	84"
<i>Avg. Swell ≥ 10%</i>	96"	96"	96"	96"	96"	96"	96"	96"	96"	96"	96"
SG Behind BOC	1-ft	1-ft	1-ft	1-ft	1-ft	1-ft	1-ft	1-ft	1-ft	1-ft	1-ft
MB Behind SG	2-ft	2-ft	2-ft	2-ft	2-ft	2-ft	2-ft	2-ft	2-ft	2-ft	2-ft

*MC = Moisture Conditioning*

*Avg. Swell = Average swell to 10 feet or top of rock, whichever is less.*

*SG = Subgrade*

*BOC = Back of Curb*

*MB = Moisture Barrier*

*\* Collectors (C2U) shall be paved with concrete having a minimum 8" thickness in commercial areas and 6" thickness in residential areas.*

*\*\* Alleys (RA) shall be paved with concrete having a minimum 8" thickness in commercial areas and 6" thickness in residential areas.*



- 3.1.D. All roadways and alleys shall have a geotechnical investigation and pavement and subgrade design performed. Results of the geotechnical investigations, engineering analyses, and recommendations shall be presented in a Geotechnical Report for Roadways (“Report”). The Report and any subsequent re-evaluations and/or supplemental reports shall be signed and sealed by a Licensed Professional Engineer in the State of Texas trained and qualified to provide geotechnical engineering analysis and pavement and subgrade design recommendations.
- 3.1.E. The Report shall address all items listed in the Geotechnical Report for Roadways Checklist (“Checklist”) in **Appendix B**. The Checklist shall be filled out completely and submitted with the Report. Any “N/A” response on the Checklist shall include a written explanation and adequate justification as deemed necessary by the Director of Engineering. Additionally, the Summary of Geotechnical Recommendations Form (“Form”) in **Appendix B** shall be filled out completely and submitted with the Report.
- 3.1.F. City review of the Report will be conducted as a means to verify if the pavement and subgrade design has been performed in general conformance to the City’s requirements, and shall not be considered a detailed technical review of the pavement and subgrade design for adequacy, accuracy, or completeness. The Geotechnical Engineer performing the pavement and subgrade design shall remain responsible for the technical adequacy, accuracy, and completeness of the pavement and subgrade design and shall not be relieved of any responsibility for such as a result of the City’s review.
- 3.1.G. The information and recommendations contained in the Report and any subsequent re-evaluation and/or supplement reports shall be accepted by the Director of Engineering in writing prior to Release of Construction.
- 3.1.H. Fire lane paving shall be designed in accordance with the City of McKinney Construction Standard Details.
- 3.1.I. The Engineer shall prepare a site-specific jointing plan for any roundabout. This includes, but is not necessarily limited to, expansion and contraction/sawed joints. Refer to **Section 2.3.E** and City of McKinney Construction Standard Details for more information on roundabouts.
- 3.1.J. Refer to the City of McKinney Construction Standard Details and Technical Specifications for additional specific requirements related to pavement and subgrade.

## 3.2. Existing Surface/Subsurface Investigation

- 3.2.A. Field Investigation elements include:
  - 1. Borings shall be drilled on center of proposed roadway, or within proposed roadway widening, at 500-foot spacing (or less), alternating between each roadway direction or on a 400-foot grid throughout a subdivision to a depth of at least 20 feet below finished subgrade or until competent rock is encountered, whichever is shallower. Where existing roadways exist, borings shall be taken just outside the limits of the existing roadway. Refer to **Section 6.4** for boring

requirements for structures. Additional borings may be requested by the Director of Engineering.

2. Borings shall be sampled at 3-foot intervals or less to a depth of 10 feet below finished subgrade, and at 5-foot intervals or less thereafter.
3. Bulk samples of each soil type encountered in the upper 5 feet shall be taken for Laboratory Investigation.

3.2.B. Laboratory Investigation elements include:

1. Moisture Content Tests (ASTM D 2216) shall be performed. When the samples are wetter than normally expected due to seasonal variability, the samples shall be air dried such that the samples represent the drier portion of the year. Average all swell test results to determine the mean maximum swell percentage and the standard deviation.
  - a. For samples taken during the months of June through September, use the mean swell percentage to determine the design swell percentage.
  - b. For samples taken during the months of October through May, use the mean plus one standard deviation to determine the design swell percentage.
2. Soil types in each boring shall be classified as follows:
  - a. Atterberg limits (ASTM D 4318)
  - b. Percent Passing the No. 200 sieve (ASTM D 1140)
  - c. Moisture/Density

3.2.C. A geotechnical re-evaluation will be required if more than two months occur between the end of moisture conditioning and beginning of liming operations; when conditions have changed significantly between moisture conditioning and liming operations; when Contractor and/or Owner have not properly maintained moisture content; or as deemed necessary by the City. The re-evaluation shall include additional field and laboratory testing to confirm moisture conditioning is still acceptable, or how to rectify the substandard condition prior to liming operations as necessary. Borings for the re-evaluation will be required on center of roadway at 1,000-foot spacing (or less) or on a 800-foot grid throughout a subdivision to a depth of at least 20 feet below finished grade or until competent rock is encountered, whichever is shallower.

3.2.D. Geotechnical investigation must address heavily treed areas, where such trees are to be removed. Additional borings may be required in these areas.

### 3.3. Subsurface Design

3.3.A. Laboratory investigation elements include determining swell characteristics and movement potential using the Swell Test and the calculated Potential Vertical Rise (PVR) – TxDOT Tex-124-E methods for a 20-foot depth of moisture penetration. The results of both tests shall be included in the Report. The Geotechnical Engineer shall use the more conservative value in determining swell potential and depths of moisture treatment.

1. Swell Test: Test for swell potential using swell test (ASTM D 4546) at 200 psf stress at least two samples per boring at varying depths from 0 feet to 10 feet to determine the average swell potential of the subgrade. Use **Table 3-1** to determine the minimum depth of moisture treatment based on average swell potential. The Geotechnical Engineer shall provide a recommendation for swell less than 2%.
2. PVR-TxDOT Tex-124-E: Test for swell potential using swell test (ASTM D 4546) and/or soil suction tests (ASTM D 5298) necessary to calculate PVR for a 20-foot moisture penetration. The PVR shall be calculated based upon 20-foot moisture penetration and shall provide moisture treatment depth to limit PVR to 4.5 inches.

3.3.B. The Geotechnical Engineer shall address transitions between zones of varying depths of moisture treatment. Zones shall remain at the most conservative depth 150 feet from the location of the boring resulting in the greatest depth, prior to transitioning to a zone with less moisture conditioning depth. In no case shall the transitions be greater than 1H:1V.

3.3.C. If street trees are proposed and within the limits of the moisture treated subgrade and moisture barriers, the Geotechnical Engineer shall address this condition in the Report and propose an alternate moisture/root barrier for the City's review.

3.3.D. If existing trees are within the limits of the moisture treated subgrade, the Geotechnical Engineer shall address this condition in the Report and propose an alternate moisture/root barrier for the City's review.

3.3.E. All subsurface improvements shall be in accordance with the Technical Specifications unless otherwise approved by the Director of Engineering.

### 3.4. Subgrade Design

3.4.A. Laboratory Investigation elements include:

1. Lime stabilization series for each soil type expected to be in the upper 12 inches of the subgrade. The Eades-Grimm method of pH testing shall be used to obtain a beginning point. Additional testing shall be performed for each soil type to determine lime content. Minimum design criteria are:

pH = 12.4 (or maximum pH) after mellowing (ASTM D 2976)

Swell potential <1.0 percent under 200 psf stress test (ASTM D 4546)

The minimum lime content shall be the percentage, by weight, of hydrated lime as determined by lime stabilization series plus 1.0%, and in no case be less than the City's minimum requirements as listed in **Table 3-1**.

2. Test for sulfates in the upper 3 feet of the subgrade in each boring using EPA 9038 or EPA 375.4 with 10:1 dilution ratio. Provide testing to determine the levels of sulfate present in all soil types in the upper 3 feet.
- 3.4.B. Formations having over 6,000 ppm (0.6%) sulfates shall be lime stabilized using a double application method. Refer to Technical Specifications for lime application methods.
- 3.4.C. Alternative subgrade options may be proposed by the Geotechnical Engineer, and may be approved by the Director of Engineering.
- 3.4.D. Flexible base, if proposed as an alternative subgrade, shall have a minimum depth of 8 inches and shall extend a minimum of 1 foot behind the back of curb. Flexible base shall meet TxDOT Specifications, Item 247, Type D, Grade 1 or 2 with Triax TX 140 Geogrid (or approved equal) under the flexible base.
- 3.4.E. All subgrade improvements shall be in accordance with the Technical Specifications unless otherwise approved by the Director of Engineering.

### **3.5. Pavement Design**

- 3.5.A. All concrete pavement shall be in accordance with Technical Specification, Standard Details, and General Notes unless otherwise approved by the Director of Engineering.
- 3.5.B. The minimum pavement sections listed in **Table 3-1** are based on the Pavement Design Input Values contained in **Table 3-2**. It is the Geotechnical Engineer's responsibility to ensure those input values are applicable. In no case shall the pavement sections be less than the City's minimum. Additional pavement reinforcing shall be evaluated and determined for all concrete pavement sections thicker than 9 inches. Pavement design shall be based on American Association of State Highway and Transportation Officials (AASHTO) current edition of *Guide for Design of Pavement Structures* utilizing WinPAS, Pavement Analysis Software. A printout from the software program shall be required.

**Table 3-2 – Pavement Design Input Values**

Input	Thoroughfare Classification										
	P6D	M6D	G6D	G4D	M4D	M4U	M3U	M3U-F	C2U	R2U	RA
Design Period (years)	30	30	30	30	30	30	30	30	30	30	30
Initial Serviceability	4.5	4.5	4.5	4.5	4.5	4.5	4.5	4.5	4.5	4.5	4.5
Terminal Serviceability	2.5	2.5	2.5	2.5	2.3	2.3	2.3	2.3	2.3	2.0	2.0
Concrete Modulus of Rupture @ 28 days (psi)	620	620	620	620	620	620	620	620	620	620	620
Concrete Modulus of Elasticity @ 28 days (psi)	5,000,000	5,000,000	5,000,000	5,000,000	5,000,000	5,000,000	5,000,000	5,000,000	5,000,000	5,000,000	5,000,000
Modulus of Subgrade Reaction* (psi/in)	TBD	TBD	TBD	TBD	TBD	TBD	TBD	TBD	TBD	TBD	TBD
Reliability	90%	90%	90%	90%	90%	90%	90%	90%	90%	85%	85%
Standard Deviation	0.35	0.35	0.35	0.35	0.35	0.35	0.35	0.35	0.35	0.35	0.35
Load Transfer Coefficient	2.9	2.9	2.9	2.9	2.9	2.9	2.9	2.9	2.9	2.9	2.9
Drainage Coefficient	1.0	1.0	1.0	1.0	1.0	1.0	1.0	1.0	1.0	1.0	1.0
Design Average Daily Traffic (ADT)	42,000	38,000	38,000	31,000	31,000	20,000	24,000	21,000	3,000	1,400	-
Traffic Growth Rate	0%	0%	0%	0%	0%	0%	0%	0%	0%	0%	0%
Percent Trucks**	2%	2%	2%	2%	2%	2%	2%	2%	1%	1%	1%
Lanes	6	6	6	4	4	4	3	3	2	2	1
Lane Distribution Factor	0.7	0.7	0.7	0.7	1	1	1	1	1	1	1

\* To be determined based on the California Bearing Ratio (CBR) value. CBR values range with soil and stabilization type. Geotechnical Engineer must document the CBR and Modulus of Subgrade Reaction in the Report.

\*\* If anticipated percentage of trucks for proposed development exceeds the minimum criteria shown in **Table 3-2**, the actual percentage shall be used.

## SECTION 4 STORMWATER DESIGN REQUIREMENTS

### 4.1. General

- 4.1.A. Purpose – The purpose of the City of McKinney’s drainage policy is to provide for the safety and welfare of the general public, mitigate flood and erosion related damages to private and public property, improve water quality, and protect aquatic resources.
- 4.1.B. Drainage Plan Submittals – Refer to **Section 1.9** and to the Civil Engineering Plan Submittal Process and Civil Engineering Plan Review Development Checklist included in **Appendix B** for plan submittal requirements.
- 4.1.C. A review process has been established by the City to provide control of all development activities related to stormwater runoff through natural or manmade facilities.
1. An approved flood study is needed prior to the submission of the pre-final plat.
  2. A Final Drainage Plan and all supporting computations, shall be submitted at the time of the record plat application. Two hard copies of any flood study or drainage report shall be submitted along with a PDF copy of the study or report and electronic copies of all computer modeling input and output data.
- 4.1.D. Drainage Structure Aesthetics – Drainage design in the urban environment must also consider appearance as an integral part of the design. In an effort to maintain the natural aesthetics of its existing floodplains, the City strongly encourages preservation of the natural floodplains as greenbelt areas, and in some cases, the City may require the floodplain to be designated as a deed restricted greenbelt area. When utilized, the design of drop structures and other hydraulic structures should blend with the natural surroundings as much as possible to maintain the aesthetics of the natural channel.
- 4.1.E. Drainage Design Computations – Computations and results of analyses to support all drainage designs shall be submitted to the Director of Engineering for review as part of the Final Drainage Plan. Computer programs and spreadsheets used to perform computations shall be limited to those referenced in this manual. All computations submitted shall be certified by an engineer experienced in municipal stormwater drainage design and licensed in the State of Texas in accordance with the requirements set forth by the Texas Board of Professional Engineers and in accordance with the McKinney Stormwater Management Ordinance. Stormwater runoff computations used for design shall be based on fully developed watershed conditions and results shall be rounded in accordance with the McKinney Stormwater Management Ordinance and this manual. There may be instances in which existing or interim conditions represent the most critical condition, and these should also be reasonably considered in the design. The goal of every design should be the protection of life and property for all reasonably foreseeable conditions (this requires the exercise of prudent engineering judgment based on experience and training).

- 4.1.F. Construction of Drainage Facilities – Development activities associated with the construction of drainage facilities must minimize erosion caused by construction, in accordance with the McKinney Stormwater Management Ordinance and **Section 8** of the Engineering Design Manual. The protection of desirable trees and vegetation shall be maximized during construction of development activities.
- 4.1.G. Maintenance of Drainage Facilities – All maintenance responsibilities shall be in accordance with the Stormwater Management Ordinance. Drainage facilities that have been dedicated to and accepted by the City are maintained by the City. Private drainage facilities are typically maintained by the property owner on which the facility is located. Some private drainage facilities are owned and/or maintained by a Homeowner's Association. In such cases, this shall be noted on the plat. Not all natural creeks and floodplain areas are owned and maintained by the City. Rather, they are owned and maintained by the property owner on which the creek or floodplain area is located. The existence of a drainage or floodplain easement does not change ownership or maintenance responsibility. Maintenance plans for detention ponds and best management practices (BMPs) are required and shall be in accordance with the Stormwater Management Ordinance
- 4.1.H. Drainage Plan Requirements – As part of the platting process, storm drainage plans shall be prepared. These plans shall coordinate the functions of drainage facilities for both off-site and on-site drainage flows. The goal of these facilities is to prevent flood and erosion damage to all public and private property from storms up to and including the fully developed 100-year storm. Criteria for on-site development shall also apply to off-site improvements. The construction of all improvements shall be in accordance with the current Construction Standards and Specifications Manual and regulations adopted by the City. If applicable to the project, Final Drainage Plans shall follow the Civil Engineering Plan Review Development Checklist and shall include:
1. Drainage Area Maps (Existing/Interim/Proposed)
  2. Drainage Calculation Sheets
  3. Storm Drain Plan and Profile Sheets
  4. Bridge Plans – Show the elevation of the lowest member of the bridge and the fully developed 100-year design water surface elevation based on the criteria in **Section 4.4** of the Engineering Design Manual. Provide a soils report and calculations and details for all erosion protection per the Stream Bank Stabilization Manual.
  5. Creek Alterations and Channel Plans – The City has an ongoing program to restore and protect its lakes and creeks. Also, individual creek master plans have been prepared and are continuing to be prepared for most of the significant creeks in McKinney. These individual creek master plans include specific recommendations on a reach-by-reach basis for stabilizing and protecting the creek. These recommendations may be followed or alternatives may be proposed to the Director of Engineering prior to commencing work in or adjacent to any creek that has a detailed master plan. In the absence of a detailed master



plan, the developer may be required to evaluate the impacts of their development on all creeks within and adjacent to their project using the methods and goals shown in the Stream Bank Stabilization Manual. Creek Alteration and Channel Plans shall indicate flow line, banks, and design water surface elevation. They shall also show standard-step backwater hydraulic computations far enough upstream and downstream to determine the hydraulic impacts of the proposed changes. See the Stream Bank Stabilization Manual for stream erosion and stability issues. Plans shall indicate existing and proposed velocities for the fully developed 5-year and 100-year flows. Refer to **Section 4.8** for open channel design requirements.

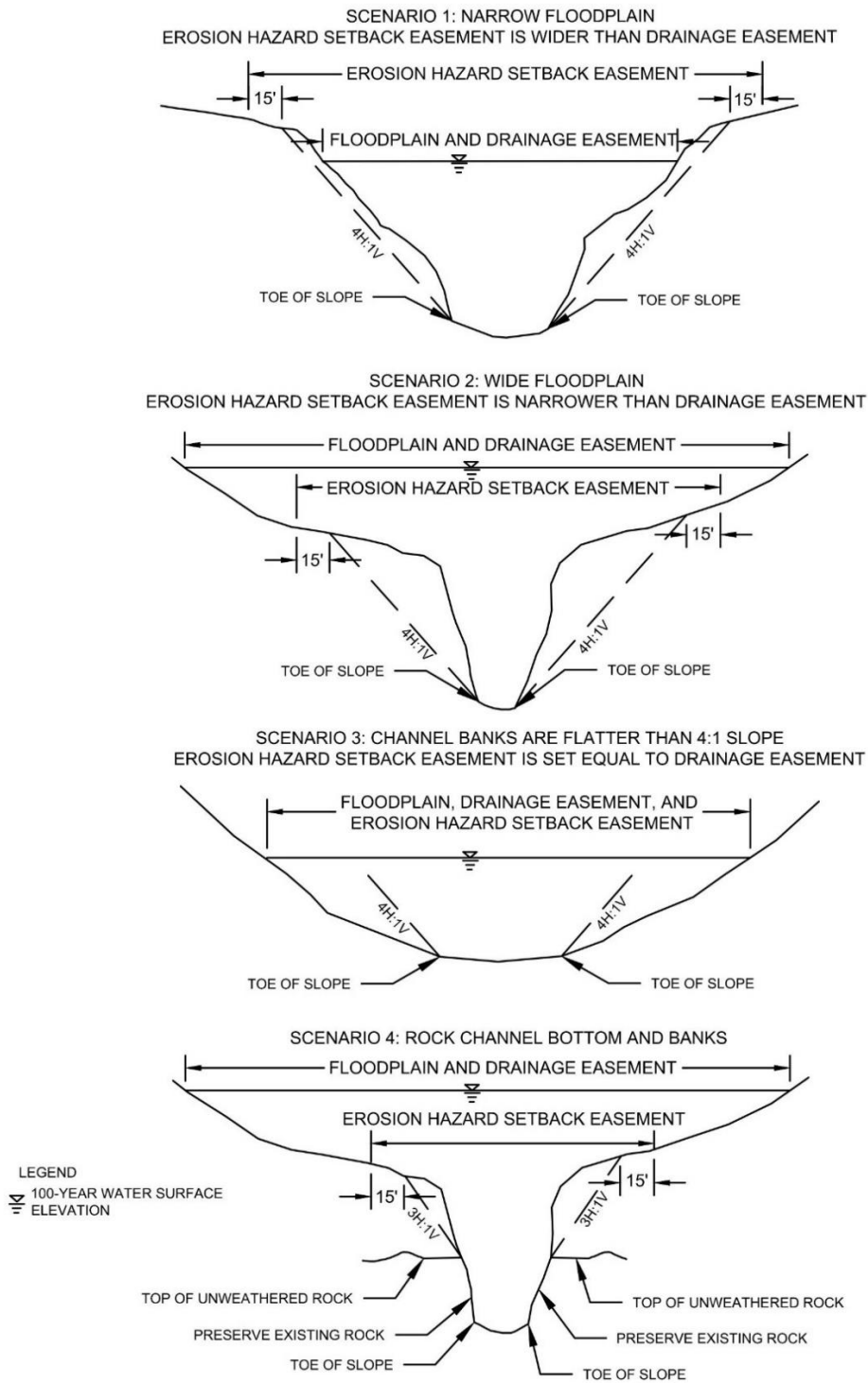
6. Environmental Reports and Plans – Refer to **Section 8** of the Engineering Design Manual for any requirements regarding Erosion Control Plans, Post Construction Stormwater Quality Plans, and Stormwater Pollution Prevention Plans.
7. Detention and Retention Facilities Plans – Detention and retention facilities are a means to mitigate the impacts of land use changes on downstream properties and drainage facilities. They are utilized to store stormwater and release it over an extended period of time. In McKinney, detention and retention facilities additionally serve as stormwater quality improvement facilities as well as frequency mitigation measures to protect the quality of the downstream receiving waters and the stability of the receiving streams. Retention facilities (those which permanently retain a volume of water) may be subject to additional TCEQ permitting requirements. Refer to **Section 4.10** for detention basin design requirements.

#### 4.1.1. Erosion Hazard Setback Easement

1. Erosion Hazard Setback Easements (EHSE) are necessary for both natural streams and man-made channels. The purpose of an EHSE is to protect structures from damage caused by erosion. No dirt fill, building, fence, wall, deck, swimming pool, or other improvements shall be constructed within an EHSE. Stream bank stabilization may be an acceptable alternative to the dedication of an EHSE provided (1) there is an approved stream bank stabilization plan and (2) there are adequate easements that allow for perpetual maintenance access of all stream bank stabilization measures. See the Stream Bank Stabilization Manual for more information. In some cases, the EHSE may extend beyond the floodplain. The procedure to determine the EHSE is as follows:
  - a. Locate the toe of the natural stream bank. The toe shall be based on the most conservative estimate of a toe of slope where erosion can occur based on the fully developed 100-year design storm. The toe may be located outside of the low flow channel.
  - b. From this toe, construct a line sloping at 4H:1V towards the bank until it intersects natural ground.



- c. From this intersection, add 15 feet horizontally in the direction away from the stream to locate the outer edge of the Erosion Hazard Setback Easement.
  - d. For channels with side slopes flatter than 4H:1V, the Erosion Hazard Setback Easement shall be set at the fully developed 100-year floodplain elevation.
2. The Erosion Hazard Setback Easement may be reduced in places where the stream banks are composed partially or entirely of rock or are appropriately stabilized per the Stream Bank Stabilization Manual. In these areas, the interface of the natural stream bank with the top of the unweathered rock strata shall be located with the assistance of a qualified geotechnical engineer or geologist, and adequate documentation of said rock shall be provided to the City. From this point, a line sloping at 3H:1V is constructed until its intersection with natural ground. The outer edge of the Erosion Hazard Setback Easement is located 15 feet in the direction away from the stream from this intersection.
  3. In all cases, provision for adequate maintenance access shall be considered when establishing the Erosion Hazard Setback Easement. Refer to **Figure 4-1** for additional guidance.



**Figure 4-1 – Natural Channels: Erosion Hazard Setback, Floodplain, and Drainage Easements**

4.1.J. Storm Drainage Easements – All proposed stormwater facilities that are outside of ROW or existing easements, shall be provided with drainage easement. The following are the minimum requirements for the easements:

1. Drainage easements shall have a minimum width of 15 feet. Additional easement width shall be provided based on depth and diameter of utilities. The minimum easement width for stormwater mains deeper than 10 feet to the bottom of pipe, shall be equal to 2.5 times the depth of the line plus the width of the line, rounded up to the nearest 5 feet. For example, a 48" wastewater main 13 feet deep. The wastewater easement would be  $(2.5 \times 13 \text{ feet}) + 4 \text{ feet} = 36.5 \text{ feet}$ , rounded up to the nearest 5 feet = 40 feet. Larger easement widths may be required by the Director of Engineering.
2. Single stormwater mains shall be located in the center of the easements. For 2 or more parallel utility mains in an easement, maintain the centerline of the utility a minimum of 7.5 feet from the edge of the easement for mains less than or equal to 10 feet deep. For mains greater than 10 feet deep, the easement width shall be 2.5 times the depth.

4.1.K. City of McKinney Stormwater Management Ordinance – Article 8 of the City of McKinney Unified Development Code is herein referred to as the Stormwater Management Ordinance. The ordinance contains requirements and guidelines for the design of stormwater management facilities.

4.1.L. General Lot Grading and Drainage Requirements

1. Lot-to-lot drainage, defined as runoff from one individually owned private lot to another, is not allowed. Once runoff is conveyed to a public right-of-way (ROW) or drainage or floodplain easement, it may not be directed back onto private property outside of a drainage or floodplain easement.
2. Grading and drainage shall not negatively impact surrounding properties.
3. Lots shall be graded to drain surface water away from the foundation walls. The grade shall fall a minimum of 6 inches within the first 10 feet. Where lot lines, walls, slopes, or other physical barriers prohibit 6 inches of fall within the first 10 feet, drains or swales shall be constructed to ensure drainage away from the structure. Impervious surfaces within 10 feet of the building foundation shall be sloped a minimum of 2 percent away from the building. All earthen drainage swales draining areas less than one cumulative acre shall have a 2 percent minimum slope. Side yards and backyards that shall have a 1 percent minimum slope. All paved drainage swales shall have a 1 percent minimum slope.

4.1.M. Significant Figures

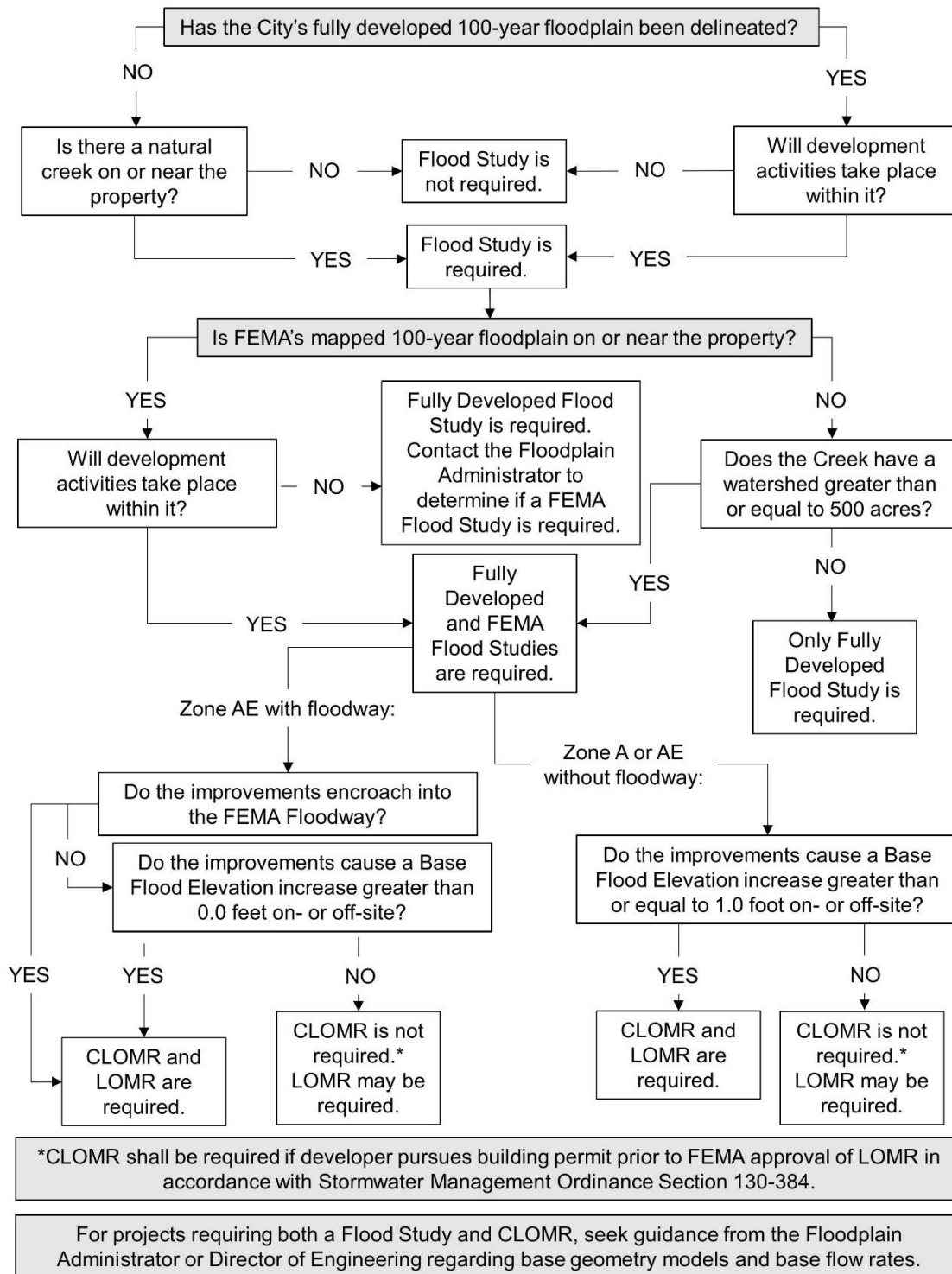
1. For encroachments within a floodway, water surface elevations in feet should be shown to 2 decimal places. In all other cases, water surface elevations should be rounded to 1 decimal place.

2. For flows less than 100 cubic feet per second (cfs), round to the nearest tenth. For flows greater than 100 cfs, round to 3 significant figures.
3. Round flow velocities in feet per second (fps) to 1 decimal place.

## 4.2. Floodplain Development Criteria

### 4.2.A. General

1. All development within the floodplain requires review and approval by the Director of Engineering.
2. Portions of the 100-year floodplain, based on fully developed watershed conditions, may be reclaimed provided that:
  - a. There is no increase in the water surface elevation (Refer to **Section 4.2.A.3**);
  - b. Acceptable velocities are maintained (in accordance with **Table 4-20**);
  - c. Channel stability in the reach being reclaimed is not adversely impacted; and,
  - d. In any stream with a contributing watershed of 200 acres or more at the point of development, an equivalent volume of valley storage must be provided in the same reach as the proposed development.
3. Increase of the floodplain water surface elevation may be considered only when the entire floodplain area experiencing the increase is located on one's own property. The only exception to this is if there are existing floodplain or drainage easements that will accommodate the FEMA and fully developed floodplain, including any increases, and fully developed 100-year capacity exists.
4. Velocities throughout the channel must be analyzed for both the fully developed 5-year and fully developed 100-year events to ensure that any new fill and grading is protected. Refer to **Section 8** for erosion control requirements.
5. All development shall be in accordance with the Unified Development Code, Article 4: Tree Preservation.
6. Listed below are the procedures that shall be followed when developing within either the current effective FEMA floodplain or the fully developed 100-year floodplain. Refer to **Figure 4-2** for guidance on floodplain development requirements.



**Figure 4-2 – Floodplain Development Flow Chart**

#### 4.2.B. Floodplain Development

1. Development in the floodplain fringe may be allowed provided the following criteria and those criteria outlined in the City of McKinney Stormwater Management Ordinance Section 705 are met:
  - a. Residential and non-residential structures are prohibited within the floodplain. Development proposed within a floodplain area must include a Reclamation Plan.
  - b. Pad elevations for residential lots raised out of the floodplain shall be at least one foot above the elevation of either the base flood or the fully developed 100-year flood elevation, whichever is greater.
  - c. Minimum finished floor elevations for proposed development areas adjacent to the floodplain shall be at least two feet above the elevation of either the base flood or the fully developed 100-year flood elevation, whichever is greater.
  - d. The top of the curb or street crown of all new streets to be built in reclaimed floodplain areas shall be at least one foot above the base flood or the fully developed 100-year flood elevation, whichever is greater.
  - e. The low beam of all new bridges to be constructed across floodplains shall be a minimum of one foot above the base flood or the fully developed 100-year flood elevation, whichever is greater.
  - f. Parking lots associated with residential uses in reclaimed floodplain areas shall be at least at the base flood or fully developed 100-year flood elevation, whichever is greater.
  - g. Parking lots for commercial and industrial uses may be built at one foot below the base flood or the fully developed 100-year flood elevation, whichever is greater.
  - h. Maximum slopes of filled areas or excavated areas not in sound rock shall not exceed 3H:1V. Any City-maintained land shall be at least on a 4H:1V slope regardless of the existence of rock with the following exceptions: when proposed as part of a landscape plan or creek stabilization plan, fill slopes, vertical walls, terracing, and other slope treatments may be considered where public safety and maintenance are not jeopardized and where no unbalancing of stream flow or upsetting of the channel's stability results.
  - i. The floodplain shall be altered only to the extent permitted by equal conveyance on both sides of the natural channel. An area of the stream cross section, in its existing condition, carrying a percentage of stream flow, will continue to carry the same percentage of stream flow after filing of the floodplain occurs. The right of equal conveyance applies to all owners and uses, including greenbelt, park areas and recreational usages. Owners may

relinquish their right to equal conveyance by providing a written agreement to the City.

- j. When constructing a swale parallel to the main channel where the swale also ties to the main channel, the lowest elevation of excavated areas shall not be lower than one-third of the depth of the main channel, as measured down from the top of bank of the main channel, or the water surface elevation resulting from the 5-year flood, whichever is lower. The Director of Engineering may consider an exception to this provision, depending upon the distance between the swale and the main channel and with the provision of appropriate stabilization of the swale outfall. The upstream end of the excavation area shall not tie into the creek, and no excavation shall be closer than 50 feet to the bank of the natural channel, except as necessary to drain. Excavation of lakes may exceed the depth indicated above. In any case, excavation in the floodplain shall not cause or allow a diversion of flood flows outside the FEMA floodway without Director of Engineering approval.
- k. When the fully developed 100-year floodplain boundary is delineated for a development project, the developer must submit to the City a GIS shapefile for all fully developed 100-year floodplain boundary lines that are delineated for the project.

2. Sequence of Action for Reclamation in FEMA Designated Floodplains:

- a. Step 1 – The developer may submit a Preliminary-Final Plat to the Director of Engineering. (Note: An approved Preliminary-Final Plat expires as determined by the Subdivision Regulations unless the Record Plat has been submitted for approval.) The Preliminary-Final Plat may be approved by the Planning and Zoning Commission and/or City Council with the condition that a flood study will be submitted and approved by the Floodplain Administrator prior to Record Plat approval. With agreement of this condition and approval of the Preliminary-Final Plat, the developer may submit a Record Plat.
- b. Step 2 – The developer shall then submit the following to the Director of Engineering:
  - i. A dual element Reclamation Plan for submittal to FEMA with HEC-RAS pre- and post-project data for the existing 100-year storm event (FEMA), and a dual element Reclamation Plan for submittal to the City with HEC-RAS pre- and post-project data for the fully developed 100-year storm event. Along with these initial submittal materials, a floodplain application and review fee to the City are required before the Reclamation Plan review is initiated. Third and subsequent reviews will require an additional fee. A listing of required fees for City review of construction plans is available on the City's website.
  - ii. The Reclamation Plan data shall include these items and reflect the following guidelines: Cross-sections shall be spaced not greater than 500 feet apart and shall be spaced and aligned to adequately represent floodplain characteristics and abrupt changes within the stream including



changes in discharges, slope, cross-sectional shape, and roughness, as well as locations of obstructions to flow and locations of drainage control facilities such as bridges, weirs, levees, and spillways. The submittal of data should include both input data and output data of the computer model, summary tables comparing results of the computed water surface elevations and flow velocities for pre- and post-project conditions, documentation of Sections 9 and 10 of the Endangered Species Act, and any other necessary State or Federal permitting. For a proposed development impacting floodplain that includes greater than 50 lots, or 5 or more acres, or is contiguous with 1,000 linear feet or greater of stream stretch, and the current FEMA map of the project area is shown as Zone A but is adjacent to a Zone AE, then the study must establish base flood elevations and a regulatory floodway. Submittal of information to FEMA should have the effect of modifying the current Zone A to Zone AE along the stream stretch adjacent to the project site.

- c. Step 3 – The City will then review and comment on the completeness and impacts of the Reclamation Plan, including the HEC-RAS data. At the City's discretion, a private consultant chosen by the City may perform the review.
- d. Step 4 – If required based on comments provided by the City, the developer shall submit a revised Reclamation Plan to the City. If the Reclamation Plan impacts the regulatory floodway by realignment or fill and results in increases to base flood elevation (**Section 4.2.B**), proceed to Step 5. If the Reclamation Plan involves only the floodplain fringe and/or floodway without rise, proceed to Step 7.
- e. Step 5 – Once approved by the City, the developer shall then submit to FEMA the final, approved, and Floodplain Administrator signed Reclamation Plan based on existing (FEMA) flows in order to obtain a Conditional Letter of Map Revision (CLOMR). At this time, the developer shall also submit a copy of the final approved Reclamation Plan based on fully developed watershed conditions to the City. All fees and submittals required by FEMA are the responsibility of the developer. No Record Plat approval or Grading Permit shall be issued for floodway fill or realignment prior to FEMA CLOMR issuance.
- f. Step 6 – If FEMA approves the CLOMR application and issues the Conditional Letter of Map Revision, the engineer or developer shall provide a copy of such to the Floodplain Administrator. At this point, the City may issue a Record Plat approval letter and approve the Development Permit and Grading Plan. Floodplain reclamation may now commence. Proceed to Step 8.
- g. Step 7 – The developer's consulting engineer shall address all comments and certify that the model and submittal data meet the requirements of FEMA and should pose no problems at the time of request for the Letter of Map Revision (LOMR). Once the City is satisfied all comments have been addressed, the City may approve the Reclamation Plan. At this time, the Record Plat may be



approved, and the City may then approve the Development Permit and Grading Plan. The project may now be released for fill activities and construction.

- h. Step 8 – After grading and compaction requirements relating to floodplain reclamation are complete, as-built (record) drawings of the reclamation project reflecting post-construction conditions based on survey data shall then be prepared for submittal to FEMA in the form of a LOMR application. The LOMR application and related materials must be submitted to the City for review and approval. Once the City Floodplain Administrator has approved and signed the application MT form, the application and appropriate fees must be submitted to FEMA by the developer or the developer’s consulting engineer to remove the reclaimed area from a Special Flood Hazard Area. If there are substantive changes from the previously submitted fully-developed study, a new, revised study is required. These submittals must include HEC-RAS data, compaction results from a geotechnical engineer certifying compaction of the fill to no less than 95 percent of the standard proctor densities of the material, and any other information required by FEMA.
  - i. Step 9 – Submit to the City a GIS shapefile for all fully developed 100-year floodplain boundary lines that are delineated for the project. The numbering for the other steps after this one will also need to be altered.
  - j. Step 10 – When FEMA issues a LOMR, the Record Plat may be filed for record. At this time, Building Permits may be issued. (Note: If FEMA rejects the submittal for the LOMR, revisions to the Record Plat may be required to modify the drainage easements to reflect the adjustments required by FEMA.)
  - k. Step 11 – Assuming all other conditions have been met, final acceptance of the development may then be given. The Certificate of Occupancy may then be issued for non-residential buildings and Building Permits for residential buildings may then be issued.
3. Sequence of Action for Reclamation in Non-FEMA Designated Floodplains:
- a. Step 1 – The developer may submit a Preliminary-Final Plat to the Director of Engineering. (Note: An approved Preliminary-Final Plat expires as determined by the Subdivision Regulations unless the Record Plat has been submitted for approval.) The Preliminary-Final Plat may be approved by the Planning and Zoning Commission and/or City Council with the condition that a flood study will be submitted and approved by the Floodplain Administrator prior to Record Plat approval. With agreement of this condition and approval of the Preliminary-Final Plat, the developer may submit a Record Plat.
  - b. Step 2 – The developer shall then submit the following to the Director of Engineering:
    - i. A dual element Reclamation Plan for submittal to the City with HEC-RAS pre- and post-project data for both the existing and fully developed 100-year storm event. Along with these initial submittal materials, a floodplain

application and review fee to the City are required before the Reclamation Plan review is initiated. Third and subsequent reviews will require an additional fee. A listing of required fees for City review of construction plans is available on the City's website.

- ii. The Reclamation Plan data shall include these items and reflect the following guidelines: cross-sections shall be spaced not greater than 500 feet apart and shall be spaced and aligned to adequately represent abrupt changes within the stream and floodplain characteristics including changes in discharges, slope, cross-sectional shape, and roughness, as well as locations of obstructions to flow and locations of drainage control facilities such as bridges, weirs, levees, and spillways. The submittal of data should include both input data and output data of the computer model, summary tables comparing results of the computed water surface elevations, and flow velocities for pre-project and post-project conditions.
- c. Step 3 – The City will then review and comment on the completeness and impacts of the Reclamation Plan, including the HEC-RAS data. At the City's discretion, a private consultant chosen by the City may perform the review.
- d. Step 4 – If required based on comments provided by the City, the developer shall submit a revised Reclamation Plan to the City.
- e. Step 5 – The developer's consulting engineer shall address all comments and certify that the model and submittal data meet the requirements of the City and should create no flooding issues after project completion. Once the City is satisfied all comments have been addressed, the City may approve the Reclamation Plan. At this time, the Record Plat may be approved, and the City may then approve the Development Permit and Grading Plan. The project may now be released for fill activities and construction.
- f. Step 6 – After floodplain grading and compaction are completed, as-built (Record) drawings of the reclamation project shall then be submitted to the City reflecting fully developed watershed conditions. This submittal must include HEC-RAS data for both existing and fully developed watershed conditions and compaction results from a geotechnical engineer certifying compaction of the fill to no less than 95 percent of the standard proctor densities of the material.
- g. Step 7 – Submit to the City a GIS shapefile for all fully developed 100-year floodplain boundary lines that are delineated for the project.
- h. Step 8 – Upon acceptance of the record drawings submittal, the Record Plat may be filed for record. At this time, Building Permits may be issued.
- i. Step 9 – Assuming all other conditions have been met, final acceptance of the development may then be given. The Certificate of Occupancy may then be issued for nonresidential buildings and Building Permits for residential buildings may then be issued.

#### 4.2.C. Floodway Realignment

1. All Floodway realignments shall be planned, designed, and constructed in accordance with FEMA, United States Army Corps of Engineers (USACE) regulations, the Stream Bank Stabilization Manual, and any pertinent creek specific master plans. Floodway realignments that impact only the submitting land owner may be approved by the Director of Engineering while realignments that will impact more than one property owner will require notification of impacted property owners. If a floodway realignment request has been approved and the realignment results in any increase in base flood elevation, the developer or the developer's consulting engineer shall submit all necessary data to the City and FEMA and is responsible for all fees required to obtain a CLOMR from FEMA.
2. Floodway realignment requests resulting in base flood elevation increases must be approved by FEMA (by obtaining a CLOMR) and the Director of Engineering prior to approval of the Record Plat. A CLOMR must be obtained from FEMA prior to issuance of a Floodplain Development Permit. Due to the typical review period required by FEMA, the developer is encouraged to submit floodway revision requests to the City as soon as possible to avoid delays in obtaining approval of the Floodplain Development Permit. Refer to **Section 4.2.B.2** for sequence of action for reclamation in FEMA designated floodplains.

### 4.3. Design Rainfall

#### 4.3.A. Rainfall Intensity-Duration-Frequency

1. Rainfall rates for drainage design purposes shall be estimated in accordance with standard technical information provided by the current edition of NCTCOG Integrated Storm Water Management (iSWM™) *Hydrology Technical Manual*. The information, guidelines and procedures contained in this publication should be utilized by the engineer of record (engineer). Collin County rainfall information from the NCTCOG iSWM™ *Hydrology Technical Manual* is provided in **Table 4-1**, derived from the equation below:

$$I = \frac{b}{(T_c + d)^e}$$

Where:

- I = average rainfall intensity corresponding to the time of concentration (inches per hour)
- T<sub>c</sub> = time of concentration (minutes)
- b, d, e = coefficients from **Table 4-1** based on the specified rainfall return period (dimensionless)

2. This rainfall information shall be used for any Rational Method design of storm drainage facilities within the City. If there are any discrepancies between the data in this manual and the referenced publication, the data from the referenced publication should be used. Storm durations shall be based on **Table 4-3**.

Table 4-1 – Collin County Rainfall Intensity Data\*

Coefficients		Return Period (years)						
		1	2	5	10	25	50	100
e		0.82667	0.79822	0.78901	0.77386	0.75875	0.74805	0.73702
b		47.053	50.523	64.259	68.951	76.069	81.634	86.709
d		9	9	11	11	11	11	11
Hours	Minutes	Rainfall Intensity (inches per hour)						
0.083	5	5.16	5.54	7.06	8.20	9.67	10.76	11.84
	6	4.81	5.17	6.59	7.65	9.03	10.06	11.07
	7	4.57	4.91	6.26	7.27	8.58	9.55	10.51
	8	4.38	4.71	6.01	6.98	8.24	9.18	10.09
	9	4.24	4.56	5.81	6.75	7.97	8.88	9.77
	10	4.12	4.43	5.66	6.57	7.76	8.65	9.51
	11	3.93	4.23	5.39	6.26	7.39	8.23	9.05
	12	3.78	4.06	5.17	6.00	7.08	7.88	8.67
	13	3.64	3.91	4.98	5.78	6.82	7.59	8.34
	14	3.53	3.79	4.82	5.59	6.60	7.33	8.06
0.250	15	3.43	3.68	4.68	5.43	6.40	7.12	7.82
	16	3.30	3.54	4.50	5.22	6.16	6.84	7.52
	17	3.19	3.42	4.35	5.04	5.94	6.60	7.25
	18	3.08	3.31	4.21	4.88	5.74	6.38	7.01
	19	2.99	3.21	4.08	4.73	5.57	6.19	6.80
	20	2.91	3.12	3.97	4.60	5.41	6.01	6.61
	21	2.84	3.04	3.86	4.48	5.27	5.85	6.43
	22	2.77	2.97	3.77	4.37	5.14	5.71	6.27
	23	2.71	2.90	3.69	4.27	5.03	5.58	6.13
	24	2.65	2.84	3.61	4.18	4.92	5.46	6.00
	25	2.60	2.79	3.54	4.10	4.82	5.35	5.87
	26	2.55	2.74	3.47	4.02	4.73	5.25	5.76
	27	2.51	2.69	3.41	3.95	4.64	5.15	5.66
	28	2.46	2.64	3.35	3.88	4.57	5.06	5.56
	29	2.43	2.60	3.30	3.82	4.49	4.98	5.47
0.500	30	2.39	2.56	3.25	3.76	4.42	4.91	5.39
	31	2.34	2.51	3.18	3.68	4.33	4.80	5.27
	32	2.29	2.45	3.11	3.60	4.24	4.70	5.16
	33	2.24	2.40	3.05	3.53	4.15	4.60	5.06
	34	2.19	2.35	2.99	3.46	4.07	4.51	4.96
	35	2.15	2.31	2.93	3.39	3.99	4.43	4.87
	36	2.11	2.27	2.88	3.33	3.92	4.35	4.78
	37	2.07	2.23	2.83	3.27	3.85	4.28	4.70
	38	2.04	2.19	2.78	3.22	3.79	4.20	4.62
	39	2.00	2.15	2.73	3.17	3.73	4.14	4.55
	40	1.97	2.12	2.69	3.12	3.67	4.07	4.48
	41	1.94	2.08	2.65	3.07	3.61	4.01	4.41
	42	1.91	2.05	2.61	3.02	3.56	3.95	4.35
	43	1.88	2.02	2.57	2.98	3.51	3.90	4.29
	44	1.86	2.00	2.54	2.94	3.46	3.85	4.23
0.750	45	1.83	1.97	2.50	2.90	3.42	3.80	4.17
	46	1.81	1.94	2.47	2.86	3.37	3.75	4.12
	47	1.79	1.92	2.44	2.83	3.33	3.70	4.07
	48	1.76	1.89	2.41	2.79	3.29	3.66	4.02
	49	1.74	1.87	2.38	2.76	3.25	3.61	3.98
	50	1.72	1.85	2.35	2.73	3.22	3.57	3.93
	51	1.70	1.83	2.33	2.70	3.18	3.53	3.89
	52	1.68	1.81	2.30	2.67	3.15	3.50	3.85
	53	1.66	1.79	2.28	2.64	3.11	3.46	3.81
	54	1.65	1.77	2.25	2.61	3.08	3.43	3.77
	55	1.63	1.75	2.23	2.59	3.05	3.39	3.73
	56	1.61	1.73	2.21	2.56	3.02	3.36	3.70
	57	1.60	1.72	2.19	2.54	2.99	3.33	3.66
	58	1.58	1.70	2.17	2.51	2.97	3.30	3.63
	59	1.57	1.69	2.15	2.49	2.94	3.27	3.60
1	60	1.55	1.67	2.13	2.47	2.92	3.24	3.57
2	120	0.95	1.03	1.33	1.57	1.87	2.11	2.35
3	180	0.70	0.76	1.00	1.18	1.43	1.62	1.82
6	360	0.41	0.45	0.60	0.72	0.88	1.00	1.13
12	720	0.24	0.27	0.36	0.43	0.52	0.60	0.68
24	1440	0.14	0.16	0.21	0.25	0.31	0.35	0.40

\*Rainfall intensities provided in Table 4-1 are based on the iSWM™ Hydrology Technical Manual dated April 2010 and revised April 2020. The current edition shall be used.

#### 4.3.B. Rainfall Depths

1. Total precipitation amounts for the various 24-hour storm events are listed in **Table 4-2**. They shall be used only for those hydrologic methods that utilize rainfall depths instead of rainfall intensities.

**Table 4-2 – 24-Hour Rainfall Depths**

Return Period (years)	24-Hour Rainfall Depth (inches)
1	2.75
2	3.63
5	4.94
10	5.92
25	7.29
50	8.45
100	9.73
500	13.79

- 4.3.C. Probable Maximum Precipitation (PMP) – PMP rainfall depths for various durations and storm sizes can be obtained from Hydrometeorological Reports No. 51 and 52, respectively. The computer program HMR52, written by the USACE, may be used to distribute the PMP over the watershed, calculating the basin average precipitation for each time step.
- 4.3.D. Dams and Impoundments – The design rainfall for sizing auxiliary spillways on dams or impoundments shall be based on a percentage of the Probable Maximum Precipitation (PMP), as specified by the TCEQ under Title 30 of the Texas Administrative Code (TAC) §299.11 – §299.17 and further explained in the *Hydrologic and Hydraulic Guidelines for Dams in Texas* prepared by the TCEQ. Refer to **Section 4.12** for additional design criteria.
- 4.3.E. Standard Project Precipitation (SPP) – The design rainfall for projects that require the USACE Standard Project Flood (SPF) shall be obtained by applying 50 percent of the Probable Maximum Precipitation (PMP), as described in **Section 4.3.C**.
- 4.3.F. Rainfall Loss Rates – Losses due to interception, infiltration, and depression storage need to be deducted from the total design rainfall to obtain the effective design rainfall. The method used to calculate the rainfall losses will depend on the method used to compute the design discharge, as described in **Section 4.4.B** of this manual. The Rational Method accounts for rainfall losses with a runoff coefficient, as described in **Section 4.4.C**. For the unit hydrograph methods described in **Section 4.4.D**, the initial-uniform constant loss method is recommended for the Snyder's unit

hydrograph method. The Natural Resource Conservation Service (NRCS) (formerly Soil Conservation Service (SCS)) Runoff Curve Number method is recommended for use with the NRCS Dimensionless Unit Hydrograph method.

#### 4.4. Determination of Design Discharge

##### 4.4.A. Design Frequencies

1. The storm frequencies shown in **Table 4-3** shall be used with fully developed watershed conditions for drainage and flood control designs in the City.

**Table 4-3 – Design Frequency and Freeboard Requirements**

Storm Drainage Facility	Frequency	Freeboard	Freeboard Reference Point
Enclosed Pipe Systems (non-sump areas)	10-year	1 foot	From Gutter Elevation
Roadside Ditches	10-year	None	From Lowest Point of Containment
Enclosed Pipe Systems Draining Sump Areas	100-year	None	From Gutter Elevation
City Street Rights-of-Way	100-year	None	From Top of Curb
Channels and Creek Improvements	100-year	1 foot	From Top of Channel or Creek and/or Based on Direction from the Floodplain Administrator
Culverts	100-year	1 foot	From Top of Curb
Bridges	100-year	1 foot	From Low Chord of Bridge
Pedestrian Bridges	10-year	None	From Low Chord of Bridge
Detention/Retention Basins*	100-year	1 foot	From Lowest Point of Containment
Structures Adjacent to Floodplains	100-year	2 foot	From Finished Floor Elevation
Dams	See <b>Section 4.12</b>	See <b>Section 4.12</b>	From Top of Dam
NRCS Dams/Structures	100-year See <b>Section 4.12</b>	2 foot See <b>Section 4.12</b>	From Fully Developed Flood Plain Line or Top of Auxillary Spillway, whichever is higher

\*No freeboard is required for detention/retention basins if a breach or overtopping of the basin would not adversely impact downstream properties

1. Storm duration shall equal or exceed the time of concentration for all evaluations and designs.
2. Designs that utilize a unit hydrograph method shall be based on the 24-hour storm and shall meet or exceed TCEQ standards, if applicable. TxDOT requirements must be met for any TxDOT facility.

#### 4.4.B. Computation Methods

1. To design drainage facilities, the Rational Method may be used to determine the runoff generated when the contributing drainage area is less than 50 acres. A unit hydrograph method shall be used to determine the runoff generated from contributing drainage areas greater than 50 acres or for locations that contain a regional stormwater detention facility upstream. The Director of Engineering may require any development with a contributing drainage areas less than 50 acres to use a unit hydrograph method. In either case, the determination of the design discharge is to be based on fully developed watershed conditions using the best available future land use projections.
2. When determining design flow rates and water surface elevations for rivers and creeks in the City, the design discharges based on fully developed watershed conditions shall be obtained from an applicable master creek study and any subsequent revisions or modifications. The Engineer must verify its accuracy related to the site under consideration for development. Check with the Floodplain Administrator for applicable master creek studies and any additional flood study information.

4.4.C. Rational Method – The Rational Method may be used to determine runoff for watersheds with drainage areas of 50 acres or less. The peak discharge rate computed by the Rational Method is given by the following relationship:

$$Q = KCIA$$

Where:

- |   |   |   |
|---|---|---|
| Q | = | peak flow rate for a given storm event on the watershed at the desired design point (cubic feet per second)   |
| K | = | frequency factor from <b>Table 4-4</b> that is intended to reflect the additional runoff that results from saturated ground conditions in larger storm events (dimensionless) |
| C | = | weighted runoff coefficient from <b>Table 4-5</b> , representing ground cover conditions and/or land use within the watershed (dimensionless)                                 |
| I | = | average rainfall intensity during the time of concentration for a given storm event from <b>Table 4-1</b> (inches per hour)   |
| A | = | drainage area contributing runoff to the desired design point (acres)   |
1. Runoff Coefficient Frequency Factor – The runoff computations should include the frequency factor, K, as identified in **Table 4-4**. This coefficient is intended to reflect the additional runoff that results from saturated ground conditions in larger



storm events. In no case should the product of the runoff coefficient and the frequency factor exceed 1.0 ( $KC \leq 1.0$ ).

**Table 4-4 – Frequency Factors**

Storm Frequency	K
less than 100-year	1.0
100-year or greater	1.15

- Runoff Coefficient – Runoff coefficients shall represent fully developed conditions based on the current edition of the City of McKinney Future Land Use Plan. A minimum runoff coefficient of 0.60 shall be used for areas not covered by the current edition of the City of McKinney Future Land Use Plan or the current edition of City of McKinney Zoning Map. **Table 4-5** provides guidelines for runoff coefficients for typical land use within the city based on the NCTCOG iSWM™ manual and past experience in the City system. A weighted runoff coefficient may be used for the design if it is more representative of the site conditions. For residential lot acreages falling between the listed residential descriptions, the higher “C” value shall be used. The weighted runoff coefficient is determined as follows:

$$C_w = \frac{A_1C_1 + A_2C_2 + A_3C_3 + \dots + A_nC_n}{A_1 + A_2 + A_3 + \dots + A_n}$$

Where:

- $C_w$  = weighted runoff coefficient (dimensionless)
- $A$  = drainage area contributing runoff to the desired design point (acres)
- $C$  = runoff coefficient from **Table 4-5**, representing ground cover conditions and/or land use within the watershed (dimensionless)



**Table 4-5 – Runoff Coefficients and Minimum Inlet Time Guidelines**

Description	C	Minimum Inlet Time/Time of Concentration T <sub>c</sub> (minutes)
Agricultural and Unimproved Areas	0.30	20
Parks and Improved Open Areas	0.35	20
Residential (≥1 acre lots)	0.45	15
Residential (1/2 acre lots)	0.55	15
Residential (1/4 acre lots)	0.60	15
Residential (1/8 acre lots)	0.65	15
Townhome, Flex Residential, and Mixed Residential	0.75	10
Multi-Family	0.85	10
Commercial, Industrial, and Business	0.85	10
Asphalt, Concrete, and Roofs	0.95	10

4.4.D. Time of Concentration (T<sub>c</sub>) – The procedures outlined in the NRCS TR-55 shall be used to determine the time of concentration (T<sub>c</sub>). This method separates the flow through the drainage area into sheet flow, shallow concentrated flow, and open channel flow and the T<sub>c</sub> is the sum of travel time for these flows. The time of concentration flow path shall be made available to the City upon request. The engineer shall compare the calculated times to the time listed in **Table 4-5**. If the calculated T<sub>c</sub> differs from the values in **Table 4-5**, the engineer shall provide information to justify the T<sub>c</sub> calculations. The total time of concentration is determined as follows:

$$T_C = T_{t1} + T_{t2} + T_{t3} + \dots + T_{tn}$$

1. Sheet Flow – The maximum allowable length for sheet flow is 200 feet for undeveloped drainage areas and 100 feet for developed areas. When selecting a sheet flow, consider vegetative cover to a height of about 0.1 feet. This is the only part of the vegetative cover that will obstruct sheet flow. The T<sub>t</sub> for sheet flow is determined using the following equation:

$$T_t = \frac{0.007(nL)^{0.8}}{(P_2)^{0.5} S^{0.4}}$$

Where:

- $T_t$  = travel time (hour)
- $n$  = Manning's roughness coefficient from **Table 4-6** (dimensionless)
- $L$  = flow length (feet)
- $P_2$  = 2-year, 24-hour rainfall (inches) ( $P_2 = 3.6$  inches for Collin County)
- $S$  = slope of hydraulic grade line land slope (feet per foot)

2. Shallow Concentrated Flow – Shallow concentrated flow begins where sheet flow ends. A projected slope should be established along the flow line for the shallow concentrated flow length. The  $T_t$  for shallow concentrated flow is determined by the following equation.

$$T_t = \frac{L}{3600V}$$

Where:

- $T_t$  = travel time (hour)
- $L$  = flow length (feet)
- $V$  = velocity (feet per second)
- $V_{\text{unpaved}} = 16.1345 S^{0.5}$
- $V_{\text{paved}} = 20.3282 S^{0.5}$
- $S$  = slope of hydraulic grade line or land slope (feet per foot)

3. Open Channel Flow – Open channel flow is where the runoff is located within a defined channel or in some cases, closed short systems. The  $T_t$  for open channel flow is determined using the following equation:

$$T_t = \frac{L}{3600V}$$

$$V = \frac{1.486}{n} R^{2/3} S^{1/2}$$

Where:

- $T_t$  = travel time (hour)
- $L$  = flow length (feet)
- $V$  = average velocity (feet per second)
- $R$  = hydraulic radius, which is the area of the flow divided by the wetted perimeter ( $R = A/P$ ) (feet)
- $A$  = cross sectional flow area (square feet)
- $P$  = wetted perimeter (feet)
- $S$  = slope of the hydraulic gradient (feet per foot)
- $n$  = Manning's roughness coefficient (dimensionless)

Table 4-6 – Sheet Flow Roughness Coefficients\*

Surface Description	n
Smooth surfaces	0.011
Fallow (no residue)	0.05
Cultivated soils	
Residue cover <20%	0.06
Residue cover >20%	0.17
Grass	
Short grass prairie	0.15
Dense grasses	0.24
Bermuda grass	0.41
Range (natural)	0.13
Woods	
Light underbrush	0.40
Dense underbrush	0.80

\*The roughness coefficients (n values) summarized in **Table 4-6** for sheet flow are not the same for open channel flow.

4. Modified Rational Method – The Modified Rational Method is used for detention pond sizing only. For further information refer to **Section 4.10**.
- 4.4.E. Unit Hydrograph Methods
1. Unit Hydrograph Methods may be used to compute stormwater discharges for all watersheds, no matter the size, but must be used for watersheds over 50 acres or watersheds where a regional stormwater detention facility exists or is anticipated upstream of the project. Acceptable methods include the NRCS Dimensionless Unit Hydrograph Method (see TR-55), Snyder’s Unit Hydrograph (see iSWM™ manual), or any other method approved in advanced by the Director of Engineering.
  2. The post development unit hydrograph method shall be based upon fully developed watershed conditions assuming no impacts from upstream or on-site detention facilities or as directed by Director of Engineering. The engineer should discuss the approach method with Director of Engineering prior to design.
  3. The runoff curve number used in design shall be based on fully developed watershed conditions. Antecedent Moisture Condition (AMC) II shall be used for all computations except for the design and/or analysis of dams, where AMC III shall be used as specified by the TCEQ. Runoff curve numbers for specific site

conditions can be found in the TR-55 manual. Derived runoff curve numbers based on actual percent imperviousness and land uses may also be used if derived in accordance with standard engineering procedures and approved by the Director of Engineering.

4. For a listing of applicable soil types, refer to the United States Department of Agriculture, Soil Conservation Service, Soil Survey of Collin County, Texas. For areas that are not included on the current edition of City of McKinney Zoning Map or Future Land Use Plan, the Curve Number shall be a minimum of 73, 82, 88 and 90 for soil types A, B, C and D, respectively.
- 4.4.F. Detention Requirements – Stormwater detention systems may be required to reduce the peak runoff from residential, commercial, business, or industrial areas as outlined in **Section 4.10** of this manual.
- 4.4.G. Hydrologic Computer Programs – HEC-HMS or HEC-1 by USACE may be used to assist the designer when using unit hydrograph methods. The designer may also utilize the TR-20 program created by the NRCS, for hydrograph analysis. Other computer programs may be used if they are included in FEMA’s list of approved programs and are approved by the Director of Engineering. Input and output data from computer program models shall be summarized on the drainage plans. In addition, electronic copies of this information shall be submitted to the City.

#### 4.5. Street Flow

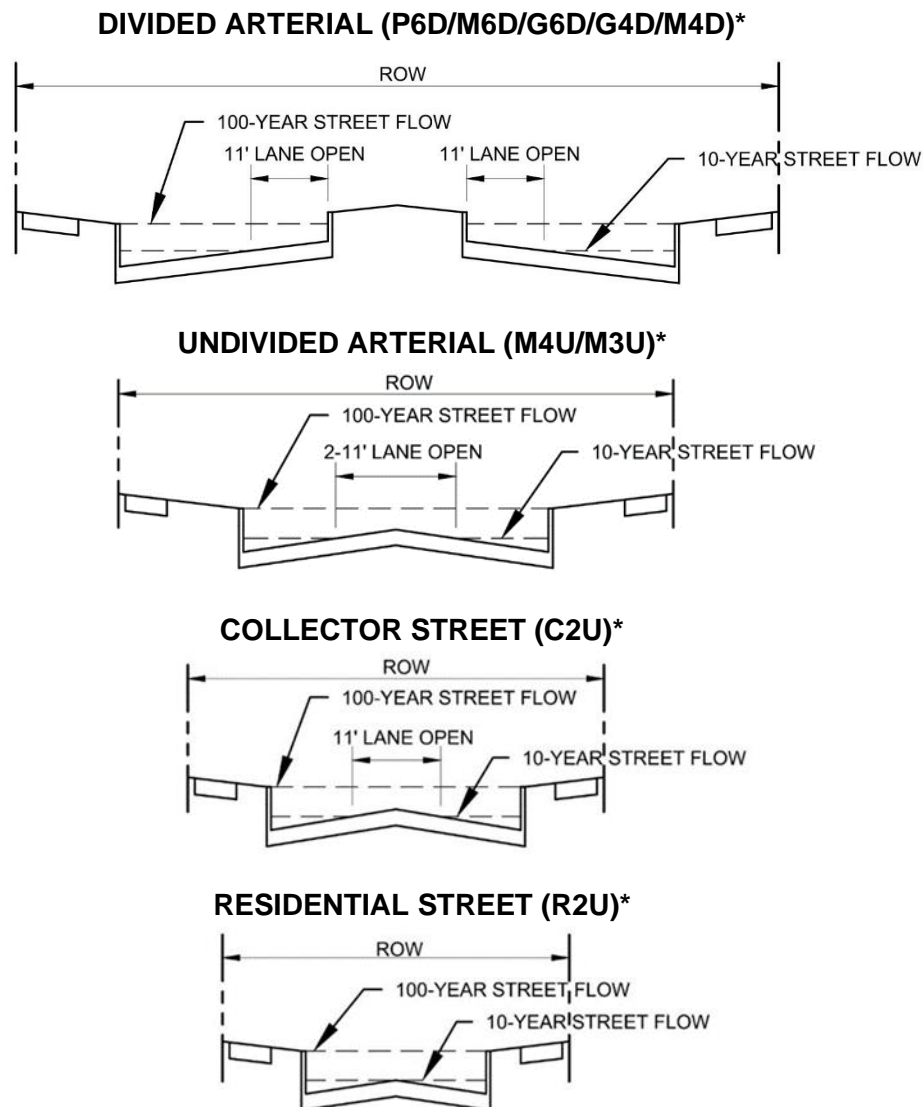
##### 4.5.A. Street Flow Limitations

1. All street flow calculations shall be based on fully developed conditions. Streets may be used to convey stormwater runoff for the 10-year and 100-year frequency storm events in accordance with the water spread limitations listed in **Table 4-7**.

**Table 4-7 – Water Spread Limits for Roadways**

Street Classification	10-year Permissible Water Spread
Arterial Streets	One 11-foot traffic lane must remain open in each direction.
Collector Streets	One 11-foot traffic lane must remain open.
Residential Streets	Water flow must not exceed the top of crown.
Street Classification	100-year Permissible Water Spread
Arterial Streets	Water flow must not exceed the top of outer lane curbs.
Collector Streets	Water flow must not exceed the top of outer lane curbs.
Residential Streets	Water flow must not exceed the top of either curb.

- For the permissible water spread limits on the 10-year frequency storm event, consideration must also be given to street conveyance of the 100-year frequency storm event. All streets shall be capable of conveying the 100-year frequency storm event without water exceeding the top of curb, as shown in **Figure 4-3**. This criterion, for utilizing the street ROW to convey the major storm runoff, may require increasing the capacity of the enclosed drainage system beyond that required for the 10-year frequency storm event. The dry lane criteria shall be met in both the interim and future conditions. Allowable depths of flow across street intersections for the 10-year frequency storm event are established as indicated in **Table 4-8**. Refer to **Section 2.2** for roadway design criteria and roadway typical sections.



\*Based on Typical Sections (Refer to **Section 2**). Not drawn to scale.

**Figure 4-3 – Maximum Water Spread Limits**

**Table 4-8 – Allowable Intersection Flows**

<b>Street Intersection</b>	<b>10-year Flow</b>
Arterial Streets	None
Collector Streets	None
Residential Streets	
Inlet(s) at Intersection (Grade < 3%)	None
Inlet(s) at Intersection (Grade ≥ 3%)	No more than 2.0 cfs
No inlets at intersection	Flow in valley gutter less than 3 inches

3. Lowering of the standard height of street crown shall not be allowed for the purposes of obtaining additional hydraulic capacity. Where additional hydraulic capacity is required, the proposed street gradient must be increased or curb inlets and storm drains installed to remove a portion of the flow. For non-curbed streets, the 100-year frequency storm event shall be safely contained within available rights-of-way.

#### 4.5.B. Street Flow Calculations

##### 1. Straight Street Sections

All straight street section capacities shall be hydraulically designed using Manning's equation:

$$Q = \frac{1.486}{n} A(R)^{2/3}(S)^{1/2}$$

Where:

- Q = discharge (cubic feet per second)
- n = Manning's roughness coefficient, 0.016 for concrete street (dimensionless)
- A = cross sectional flow area (square feet)
- R = hydraulic radius of the conduit, which is the area of the flow divided by the wetted perimeter (R= A/P) (feet)
- P = wetted perimeter (feet)
- S = slope of the hydraulic gradient (feet per feet)

2. Gutter Flow – The following form of the Manning's equation should be used to evaluate gutter flow hydraulics:

$$Q = \frac{0.56}{n} (S_x)^{5/3} (S)^{1/2} (T)^{8/3}$$

Where:

- Q = discharge (cubic feet per second)
- n = Manning's coefficient of roughness, 0.016 for streets and alleys (dimensionless)
- S<sub>x</sub> = pavement cross slope (feet per feet)
- S = longitudinal slope of the gutter (feet per feet)
- T = spread of flow or ponding width (feet)

Depth of flow in the gutter can be calculated using the following equation which is modified from of the equation above. If the flow in the gutter is still excessive, the storm drain shall be extended to a point where the gutter flow can be effectively intercepted by curb inlets.

$$y_o = z \left( \frac{QnS_x}{(S)^{1/2}} \right)^{3/8}$$

Where:

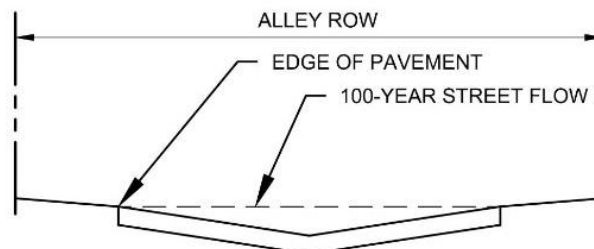
- y<sub>o</sub> = depth of water in the curb and gutter cross section (feet)
- z = 1.24 (dimensionless)

### 3. Parabolic Street Sections

All parabolic street section capacities shall be hydraulically designed using Manning's equation. See the current edition of the Federal Highway Administration (FHWA) *Hydraulic Circular No. 22* for applicable equations.

- 4.5.C. Alley Flow Limitations – Runoff created by the 100-year frequency storm shall be contained within the capacity of all paved alleys. Alley capacities shall be checked at all alley turns and "T" intersections to determine if curbing is needed or grades should be adjusted. Curbing shall be required for at least 10 feet on either side of an inlet in an alley and on the other side of the alley so that the top of the inlet is even with the high edge of the alley pavement, as seen in **Figure 4-4**. Alleys adjacent to a drainage channel shall be required to have curbs for the full length of the channel. Combination inlets shall be used in alleys.

#### RESIDENTIAL ALLEY (RA)\*



\*Based on Typical Sections (Refer to **Section 2**). Not drawn to scale.

**Figure 4-4 – Maximum Water Spread Limits for Alleys**

4.5.D. Alley Flow Calculations – Flow in alleys is also based upon open channel hydraulics theory with Manning’s equation modified to allow direct solution with regard to the alley cross section. The depth of flow for a triangular cross section can be calculated by the following equations:

$$Q = \frac{1.486}{n} A(R)^{2/3}(S)^{1/2}$$

$$A = zy^2$$

$$R = \frac{A}{P}$$

$$P = 2y\sqrt{1+z^2}$$

$$T = 2zy$$

Where:

Q	=	discharge (cubic feet per second)
n	=	Manning's coefficient of roughness, 0.016 for streets and alleys (dimensionless)
A	=	cross sectional area (square feet)
R	=	hydraulic radius (feet)
S	=	longitudinal slope of the gutter (feet per feet)
z	=	inverse of the crown slope (feet per feet)
y	=	depth of flow (feet)
P	=	wetted perimeter (feet)
T	=	spread of flow or ponding width (feet)

## 4.6. Inlet Design

4.6.A. Inlet Design Considerations – The hydraulic efficiency of storm drain inlets varies with the amount of gutter flow, street grade, street crown, and the geometry of the inlet opening. The following are some considerations that must be given attention during inlet design:

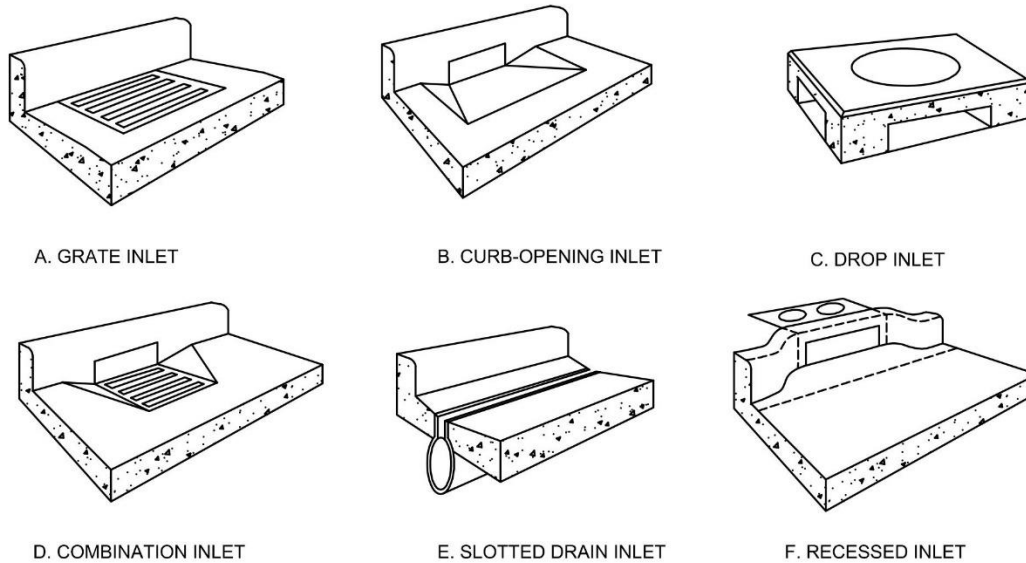
1. All inlet calculations shall be based on fully developed conditions.
2. Inlets must be located where the allowable street flow capacities are exceeded (specified in **Table 4-7**), at low points (sumps or sags), and upstream of transitions between normal and super-elevated street sections.
3. Inlets must be located at intersections where cross flow capacities are exceeded (specified in **Table 4-8**).
4. A bypass flow of no more than 2 cfs will be allowed for the design year storm at street intersections with grades of three percent or greater. No bypass flow will be allowed for inlets at street intersections with grades less than 3 percent.



5. For storms up to and including the 10-year frequency event, water flowing in arterial streets shall be intercepted by an inlet prior to super-elevated sections, to prevent water from flowing across the roadway.
6. In super-elevated sections of divided arterial streets, inlets placed against the center medians shall have no gutter depression. Interior gutter flow (flow along the median) shall be intercepted at the point of super-elevation transition, to prevent pavement cross flow.
7. At bridges with curbed approaches, gutter flow shall be intercepted prior to flowing onto the bridge to prevent ice from developing during cold weather.
8. The maximum approved vertical inlet opening is 6 inches. Openings larger than 6 inches require approval of the Director of Engineering and, if approved, must contain a bar or other form of restraint to prevent entry by a child and/or objects.
9. The design and location of all inlets must take into consideration pedestrian and bicycle traffic. In particular, if grate inlets are used, they should be designed for safe passage of bicycles.
10. Grate inlets may be used only where restrictions prohibit the use of other types of inlets. If used, the inlet opening should be designed to be twice as large as the theoretical required area to compensate for clogging and must be approved by the Director of Engineering.
11. Combination curb inlets (with opening in curb and grate opening in gutter) may be used only where space behind the curb prohibits the use of other inlet types.
12. Where recessed inlets are required, they shall not decrease the width of the sidewalk or interfere with utilities.
13. Recessed inlets must also be depressed. The gutter depression for recessed inlets shall be 4 inches.
14. Non-recessed, depressed inlets shall have a gutter depression of 4 inches.
15. The use of slotted drains is not allowed except in instances where there is no alternative, in which case approval must be obtained from the Director of Engineering. If slotted drains are used, the inlet capacity shall be the lesser of the calculated capacity from this manual or the manufacturer's design guidelines.
16. Curb inlets shall be sized accordingly along residential frontage to prevent conflicts with proposed driveways and curb returns. The Director of Engineering may limit the maximum inlet opening size where the possibility for a conflict may exist.

4.6.B. Inlet Types and Descriptions – Stormwater inlets are used to remove surface runoff and convey it to a storm drainage system.

1. For curb inlets on grade, the depressed-recessed curb inlet is recommended due to its superior interception efficiency. In areas where there is insufficient room to construct the recessed inlet, other inlet types may be used with the permission of the Director of Engineering. The other on grade inlet types are listed below:
  - a. grate inlets
  - b. curb-opening inlets (depressed, non-recessed inlets or non-depressed, non-recessed curb inlets)
  - c. drop inlets
  - d. combination inlets (with or without sweeper inlet)
  - e. slotted drain inlets (slot inlets)
2. For purposes of this manual, inlets are divided into the classes shown in **Figure 4-5**.



**Figure 4-5 – Types of Inlets**

- a. Grate Inlets – Although grate inlets may be designed to operate satisfactorily in a range of conditions, they may become clogged by floating debris during storm events. In addition, they can produce a hazard to wheel-chair and bicycle traffic and must be designed to be safe for both. For these reasons, they may be used only at locations approved by the Director of Engineering where restrictions prohibit the use of other types of inlets. Refer to the current edition of the FHWA *Hydraulic Engineering Circular No. 22* for grate inlet types and designs.
- b. Curb Inlets
  - i. Curb inlets (both recessed and non-recessed) are the most effective type of inlet on slopes flatter than 3 percent, in sag locations, and with flows that typically carry large amounts of debris. Similar to grate inlets, curb inlets also tend to lose capacity as street grades increase, but to a lesser degree than grate inlets.
  - ii. For curb inlets on grade in McKinney, the depressed-recessed curb inlet is recommended due to its superior interception efficiency. In areas where there is insufficient room to construct the recessed inlet, other inlet types may be used with the permission of the Director of Engineering. Depressed-recessed curb inlets shall be used on all major thoroughfares.
- c. Drop Inlets – Drop inlets are most often used in drainage of swales and sags.
- d. Combination Inlets
  - i. A combination inlet, consists of both the grate inlet and the curb inlet. This configuration provides many of the advantages of both inlet types. The combination inlet also reduces the chance of clogging by debris with flow into the curb portion of the inlet. If a curb opening is extended on the upstream side of the combination inlet it will act as a sweeper, and remove debris before it reaches the grate portion of the inlet. Combination inlets may be used, with the permission of the Director of Engineering, in areas where a depressed inlet cannot be constructed due to space constraints. The only combination inlets that are allowed in a sump are the Sag Curb and Grate P-1-7/8, P-1-1/8, P-1-7/8-4, and Reticuline inlets.
  - ii. Combination inlets used in a sump shall have a minimum of a 5-foot sweeper curb inlet on both sides. Combination inlets on grade will have a minimum of a 5-foot sweeper curb inlet on the upstream side. The sweeper curb inlet capacity shall be calculated as if operating alone. The flow that bypasses the sweeper inlets will then be used for the sizing of the grate inlet in the sump.
- e. Slot Inlets – Although slotted drains can be used to intercept sheet flow or flow in wide sections, they are not recommended for use in the City since they are very susceptible to clogging from debris. Slot inlets may only be used with the permission of the Director of Engineering. If slot inlets are allowed, the inlet capacity shall be calculated by equations for a grate inlet in

**Section 4.6.C.1.a** as well as the manufacturer's design guidelines. The more conservative method shall be used for design.

4.6.C. Inlet Capacity Calculations – Stormwater inlets can be further classified into three groups: sump inlets, un-depressed inlets on grade, and depressed inlets on grade. Calculation of the capacity for each inlet type and group that pertains to it is discussed in this section. Many of the equations used for the calculation of inlet capacity came directly from, or are modified forms of, equations found in the current edition of the FHWA *Hydraulic Engineering Circular No. 22*. Refer to the current edition of the FHWA *Hydraulic Engineering Circular No. 22* for any figures, charts, and nomographs that may be used in conjunction with the equations in this section to determine the capacity for various inlet configurations. It is the responsibility of the engineer to submit inlet capacity calculations for all storm drain systems to the City for review and approval.

1. Inlets in a Sump – Inlets in a sump are to be designed to have sufficient capacity to capture all of the flow from the 100-year frequency storm event. This includes the flow from the area that contributes directly to the inlets in a sump, as well as any by-pass flow from inlets upstream of the sump. It should be noted that the longitudinal slope of the roadway decreases in the vertical curve near a sump, which may cause additional ponding and spread width. Also, no by-pass flow is allowed from a sump location, and the depth of water required to create sufficient head for the inlet to capture all the flow may be greater than the normal flow depth for a given roadway. As a result, the depth,  $y$ , may require adjustment to build up sufficient head. This larger "y" will increase the ponding and spread width of the water. Additional length of the sump inlet, or additional inlets or inlet length upstream of the sump inlet may be required to limit the spread width to the acceptable limits specified in **Section 4.4**.
  - a. Grate Inlets in a Sump – If the Director of Engineering approves the use of a grate inlet in a sump, it must have a minimum of a 5-foot sweeper curb inlet on both sides. When a sweeper curb inlet is used, the capacity of that portion of inlet that does not have a grate will be calculated as if operating alone. The flow that will bypass the sweeper curb inlets will then be used for the sizing of the grate inlet in the sump.
    - i. A grate inlet in a sump or sag operates under either weir or orifice flow. Capacity calculations for both conditions will be performed and the lesser of the two capacities will be the design capacity of the grate inlet. Due to the fact that grate inlets in a sump are prone to clog, calculations should be performed with the assumption that 50 percent is clogged and does not contribute to interception. The effective perimeter of the grate shall be reduced accordingly due to the clogging.
    - ii. The only grate types that are acceptable in a sump location are the P-1-7/8, P-1-1/8, P-1-7/8-4, and Reticuline grates. Capacity of a grate inlet in a sump under weir conditions shall be calculated by the following equation:

$$Q_i = C_w P(d)^{3/2}$$

Where:

- $Q_i$  = the capacity of grate inlet under weir conditions (cubic feet per second)
- $C_w$  = the weir coefficient of 3.0 (dimensionless)
- $P$  = the perimeter of the grate inlet, disregarding the side against the curb (feet)
- $d$  = the average depth across the grate, which is the average of the approach gutter flow depth and the depth at the inlet depression, (feet)

- iii. Capacity of a grate inlet in a sump location under orifice flow conditions shall be calculated by the following equation:

$$Q_i = C_o A_g (2gd)^{1/2}$$

Where:

- $Q_i$  = capacity of grate inlet under orifice conditions (cubic feet per second)
- $C_o$  = orifice coefficient of 0.67 (dimensionless)
- $A_g$  = clear opening area in the grate (square feet). Effective area ratios for the different grate inlet types can be found in **Table 4-9**.
- $g$  = acceleration due to gravity, 32.2 (feet per second squared)
- $d$  = average depth of flow across the grate, which is the average of the approach gutter flow depth and the depth at the inlet depression, or the adjusted head required to accept the 100-year frequency storm event, whichever is greater (feet)

**Table 4-9 – Grate Effective Area**

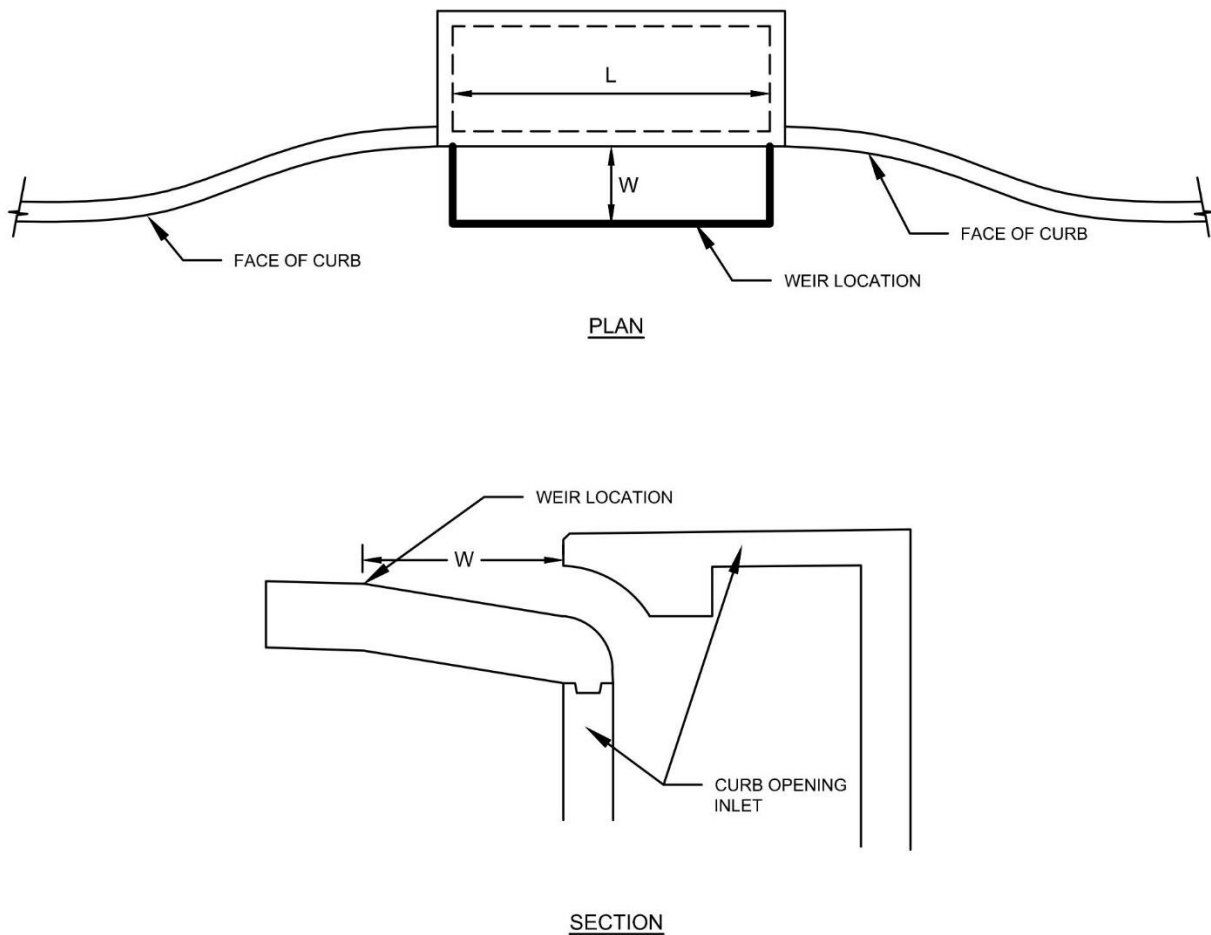
Inlet	Opening Ratio
Sag Grate P-1-7/8	0.90
Sag Grate P-1-1/8	0.60
Sag Grate P-1-7/8-4	0.80
Sag Reticuline	0.80

- b. Curb Inlets in a Sump – Curb inlets and recessed curb inlets that are located in a sump or a low point are generally considered to function as rectangular broad-crested weirs. The capacity of an inlet in a sump should be based on the following weir equation:

$$Q_i = C_w(L+1.8W)(d)^{3/2}$$

Where:

- $Q_i$  = interception capacity of a curb-opening inlet (cubic feet per second)
- $C_w$  = weir coefficient, 2.3 for depressed gutters and 3.0 for non-depressed curb-opening inlets (dimensionless)
- $L$  = length of curb opening, or the portion of perimeter of inlet opening through which water enters the drop inlet as shown in **Figure 4-6** (feet)
- $W$  = lateral width of the depression or the gutter as shown in **Figure 4-6** (feet).  $W = 0$  if there is no depression or if the inlet length is greater than 12 feet.
- $d$  = depth of flow at the inlet measured from the normal cross slope, with the limitation that the depth is less than or equal to the height of the curb (feet)



**Figure 4-6 – Curb Inlet in a Sump Diagram**

- i. Inlets should be located frequently enough along the street that the inlet openings do not become submerged. When the depth of flow is more than 1.4 times the height of the opening of the inlet, the inlet operates under completely submerged conditions and the orifice equation should be used to compute the inlet capacity. The capacity of a completely submerged inlet is derived from following orifice equation:

$$Q_i = C_o h L (2gd_o)^{1/2}$$

Where:

- $Q_i$  = capacity of curb opening inlet or drop inlet under submerged conditions (cubic feet per second)
- $C_o$  = orifice coefficient of 0.67 (dimensionless)
- $h$  = height of the curb opening (feet)
- $L$  = length of the orifice opening (feet)
- $g$  = acceleration due to gravity, 32.2 (feet per second squared)
- $d_o$  = effective head at the center of the orifice opening (feet)

- c. Combination Inlets in a Sump – The capacity of the combination inlet is 100 percent of the capacity of the grate inlet alone in a sump as determined by the equation in **Section 4.6.C.1.a.ii** when in weir flow. In orifice flow, the capacity of the combination inlet is equal to the capacity of the grate plus the capacity of the curb opening as determined by the equations in **Sections 4.6.C.1.a.ii** and **4.6.C.1.b**.
2. Drop Inlets – Drop inlets shall be located to collect water on non-paved areas where it is not practical to use a headwall. The following equation shall be used to determine the capacity of a drop inlet:

$$Q = P3.0(y)^{3/2}$$

Where:

- $Q$  = flow (cubic feet per second)
- $P$  = perimeter of opening (feet)
- $y$  = head/depth (feet)

3. Inlets on Grade – Inlets on grade are to be placed to provide sufficient capacity to capture the flow from both the 10-year and 100-year frequency storm events as outlined in **Section 4.5**. Inlets on grade generally do not suffer diminished capacity due to floating debris. They do, however, suffer from diminished capacity from excessive street grades. In general, more inlet length will be required to remove the same flow from a steeper roadway than from a flatter roadway.
  - a. Grate Inlets on Grade – If the use of grate inlets is approved by the Director of Engineering, then refer to the charts and nomographs of the current edition

of the FHWA *Hydraulic Engineering Circular No. 22* to determine the capacity of the grate inlets.

- b. Curb Inlets on Grade – Curb inlets on grade are classified into three groups: curb inlets that have no depression and are not recessed, curb inlets that are depressed but not recessed, and curb inlets that are both depressed and recessed.
- i. The calculation of the amount of flow intercepted by a curb inlet on grade is the same for all the types of curb inlets. It requires the calculation of the length of inlet required to intercept the entire flow,  $L_T$ , which is given by the equation:

$$L_T = K_C Q^{0.42} S_L^{0.3} \left( \frac{1}{n S_e} \right)^{0.6}$$

Where:

- $K_C$  = the coefficient 0.6 (dimensionless)  
 $Q$  = the total gutter flow (cubic feet per second)  
 $S_L$  = the longitudinal slope of the roadway, (feet per foot)  
 $n$  = Manning's roughness coefficient, 0.016 for streets (dimensionless)  
 $S_e$  = the equivalent cross slope in cross sections with a depression (feet per foot). This is  $S_x$  if there is no depression.

$$S_e = S_x + \left( \frac{a}{W} \right) E_o$$

Where:

- $S_e$  = equivalent cross slope of the roadway (feet per foot)  
 $S_x$  = cross slope of the roadway (feet)  
 $E_o$  = ratio of frontal or gutter flow to total flow (dimensionless)  
 $a$  = gutter depression depth as shown in **Figure 4-7** (feet)  
 $W$  = gutter depression width as shown in **Figure 4-7** (feet)

$$E_o = 1 - \left( 1 - \frac{W}{T} \right)^{8/3}$$

Where:

- $E_o$  = ratio of frontal or gutter flow to total flow (dimensionless)  
 $W$  = width of depressed gutter or grate (feet)  
 $T$  = total spread of water (feet)



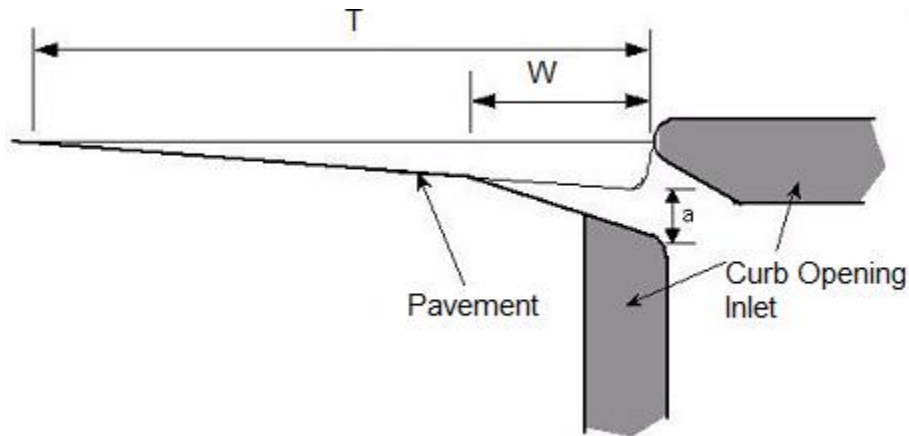


Figure 4-7 – Gutter Cross Section Diagram

- ii. The amount of flow that a curb inlet on grade will intercept is equivalent to the product of the total flow and the efficiency of the inlet, E, determined by the equation:

$$E = 1 - \left(1 - \frac{L}{L_T}\right)^{1.8}$$

Where:

- E = efficiency of the inlet (dimensionless)  
 L = actual inlet length (feet)  
 $L_T$  = length of inlet required to intercept flow (feet)

- c. Combination Inlets on Grade – The capacity of the combination inlet portion on grade is 100 percent of the grate capacity on grade while neglecting the curb opening, as determined in **Section 4.6.C.3.a**.
- d. Slot Inlets on Grade – Slot inlets may only be used with the permission of the Director of Engineering. If slot inlets are allowed, the inlet capacity shall be calculated by equations for a grate inlet in a sump found in **Section 4.6.C.1.a** or the manufacturer’s design guidelines. The more conservative method of the two shall be used.

## 4.7. Storm Drain Design

- 4.7.A. Applicable Design Criteria – Storm drain systems are needed where the water depth, water spread, and/or intersection cross flow limits specified in **Section 4.5** of this manual are exceeded. Unless approved by the Director of Engineering, open channels shall not be permitted when the inside pipe diameter required to carry the fully developed 100-year flow is 60 inches or less. Exceptions to this would be residential estate subdivisions and other areas where there are significant natural features, including trees, springs, exposed channels, and other environmental items that would work positively into the aesthetics of a development. Open channels may

be in the form of natural channels, or they may be lined. Lining materials may include, but are not limited to, concrete, gabions, concrete segmental retaining walls, and interlocking block. The following are guidelines that shall be considered and met in storm drainage design:

1. The minimum lateral storm drain pipe diameter shall be 18 inches, except in sump areas, which shall be at least 21 inches in diameter. The minimum pipe diameter for a trunk line pipe shall be 24 inches.
2. Pipe diameters shall increase downstream.
3. Stormwater mains shall be located along the centerline of the outside travel lane, furthest from the water main.
4. At points of change in storm drain size, pipe crowns shall be set at the same elevation.
5. Laterals shall be connected to trunk lines using manholes or manufactured wye connections. Special situations may require laterals to be connected to trunk lines by a cut-in. However, such cut-ins must be approved by the Director of Engineering and shown as a detail in the plan set.
6. Vertical curves in the storm pipe will not be permitted, and horizontal curves must meet manufacturer's requirements for offsetting of the joints.
7. To prevent sedimentation in enclosed systems, a minimum full flow velocity of 2.5 feet per second or partial flow velocity of 2.0 feet per second shall be maintained.
8. Minimum pipe slope shall be 0.2% unless otherwise approved by the Director of Engineering.
9. The roughness coefficients listed in **Table 4-10** shall be used in Manning's equation.
10. Concrete pipe collars or manufactured transition pieces must be used at all pipe size changes on trunk lines and where the algebraic slope difference for the vertical grade change is less than 3 percent.
11. No more than one trunk line size change between manholes or junction boxes is allowed unless otherwise approved by the Director of Engineering.
12. The maximum manhole or junction box spacing for storm drain systems is shown in **Table 4-11**, and based on iSWM™ recommendations. Manholes and junction boxes must also be located at the following scenarios:
  - a. Concentration points having three or more laterals;
  - b. Trunk line size changes for lines with a diameter difference greater than 18 inches;

- c. Vertical alignment changes where the algebraic slope difference is greater than or equal to 3 percent; and,
  - d. Future collection points as determined by the Director of Engineering.
13. Additional manholes may be required at intermediate points as determined by the Director of Engineering. Junction boxes shall be designed in accordance with **Section 6** of this manual by a licensed professional engineer.

**Table 4-10 – Storm Drain Roughness Coefficients**

Material	Minimum Roughness Coefficient n
Concrete Pipe	0.013
Corrugated-metal Pipe *	
Plain or Coated	0.024
Concrete Lined	0.013
Plastic Pipe *	
Smooth	0.011
Corrugated	0.024

\*Requires approval of the Director of Engineering and will not be allowed beneath pavement in public drainage easements and in the ROW.

**Table 4-11 – Maximum Spacing of Manholes and Junction Boxes**

Pipe Diameter (inches)	Maximum Spacing (feet)
≤ 24	300
27 - 36	400
39 - 54	500
≥ 60	1,000

- 4.7.B. Design Parameters – In addition to the criteria listed above, there are several general design guidelines to be observed when designing storm drains that will tend to alleviate or eliminate common problems of storm drain performance:
1. Select pipe size and slope so that the velocity of flow will increase progressively down the system or at least will not appreciably decrease at inlets, bends or other changes in geometry or configuration.

2. For all pipe junctions other than manholes and junction boxes, manufactured wye connections should be used, and the angle of intersection shall be 45 or 60 degrees. This includes discharges into box culverts and channels. Special circumstances may require cut-ins instead of manufactured wye connections; the use of cut-ins must be approved by the Director of Engineering.
  3. Inlet laterals will normally connect only one inlet to the trunk line. Special circumstances requiring multiple inlets to be connected with a single lateral shall be approved by the Director of Engineering.
  4. Storm drain pipe type proposed for underground detention shall be submitted for review and approval by Director of Engineering prior to installation.
  5. All storm drain pipes on public facilities shall be reinforced concrete pipe. Concrete pipe shall be a minimum of a Class III load class, but a higher class may be required based on expected loading.
  6. Minimum depth of cover for storm drain pipes is 1 foot and shall not be located within the roadway subgrade. Additional depth of cover may be required as directed by the Director of Engineering.
  7. The flow regime shall be determined for all pipes in partial flow. If supercritical flow is anticipated, the location of any potential hydraulic jumps shall be determined and noted on the plans. The precise procedure for this determination is not covered in this manual. In areas where hydraulic jumps are anticipated, additional erosion control measures may be required as directed by the Director of Engineering.
  8. Maximum flow velocities in conduits are important because of the possibility of excessive erosion of the storm drain pipe material itself. **Table 4-12** lists the maximum velocities allowed. The maximum flow velocity at the outlet of an enclosed pipe system shall be consistent with the maximum allowable velocity for the receiving channel (refer to **Section 4.8**).
- 4.7.C. All outfalls to natural channels shall be analyzed for erosion impact. All outfalls along creeks, streams, lakes and water bodies shall discharge at the center of the flow line. For this analysis, the depth of flow in the pipe at the outfall shall be the greater of either (1) the critical flow depth in the pipe or (2) the natural low water level of the creek, pond, or channel. This concept is important because the critical flow velocity that corresponds to critical flow depth is generally higher than full flow velocity. Discharges that have been concentrated in a drainage system shall be conveyed in improvements to the flowline of the receiving channel. An evaluation shall be made of the receiving stream using methods described in the Stream Bank Stabilization Manual to determine if significant degradation or aggradation is anticipated in the foreseeable future. Erosion protection is required for disturbed banks of natural channels and may be required on the opposite bank as well and/or up and downstream based on an evaluation using the methods described in the Stream Bank Stabilization Manual.

**Table 4-12 – Maximum Storm Drain Flow Velocity**

Storm Drain Type	Maximum Velocity (feet per second)
Inlet Laterals (shorter than 30 feet)	No Limit
Inlet Laterals (30 feet or longer)	20
Trunk Lines	20

1. When flow depths and velocities indicate the possibility of a hydraulic jump (a change in Froude Number from less than 1.0 to greater than 1.0), conjugate depths, the height of the jump, and the location of jump shall be determined. Because a hydraulic jump can occur even in closed conduits with surprisingly bad effects, additional measures may be required to control any negative impacts of such a phenomenon.
- 4.7.D. Calculation of the Hydraulic and Energy Grade Lines – The hydraulic grade lines (HGL) for both the 10-year and 100-year frequency storm events shall be computed and plotted for all storm drain systems. The 10-year frequency storm HGL shall be at least one foot below the gutter elevation at the entrance to all inlets. The 100-year HGL shall be within the spread of flow requirements as outlined in **Figure 4-3** and **Table 4-7**. For designs that contain sumps, the 100-year hydraulic grade line is required from the system outfall to the most upstream sump. The determination of friction losses and minor losses are required for these calculations. The energy grade line (EGL) shall be computed and plotted for all storm drains in which the design velocity is expected to exceed 12 feet per second. It is the responsibility of the engineer to submit calculations in tabular form on the plans of the HGL and EGL for all storm drain systems to the City for review and approval. Many forms of the equations used in this section are directly from or modified forms of equations found in the current version of the FHWA *Hydraulic Engineering Circular No. 22*. Reference that document for a more detailed analysis of these concepts.
1. Starting Tailwater Conditions – The designer must determine the tailwater conditions at the downstream end of the proposed storm drain system when calculating the hydraulic performance of the system.
    - a. When proposed storm drains are to discharge into existing watercourses, the tailwater elevation used in hydraulic calculations of the proposed storm drain system will be determined by the engineer and approved by the Director of Engineering. The tailwater elevation shall be the greater of the water surface elevation of the receiving stream or the minimum outlet water surface elevation,  $y_m$ , both in feet above mean sea level (feet msl).
    - b. When proposed storm drains are to discharge into existing watercourses, the storm frequency for the receiving watercourse used to determine the starting tailwater elevation shall be based on **Table 4-13**.

**Table 4-13 – Frequencies for Coincidental Occurrences\***

Area Ratio	2-year design		5-year design	
	Main Stream	Tributary	Main Stream	Tributary
10,000:1	1	2	1	5
	2	1	5	1
1,000:1	1	2	2	5
	2	1	5	2
100:1	2	2	2	5
	2	2	5	5
10:1	2	2	5	5
	2	2	5	5
1:1	2	2	5	5
	2	2	5	5
Area Ratio	10-year design		25-year design	
	Main Stream	Tributary	Main Stream	Tributary
10,000:1	1	10	2	25
	10	1	25	2
1,000:1	2	10	5	25
	10	2	25	5
100:1	5	10	10	25
	10	5	25	10
10:1	10	10	10	25
	10	10	25	10
1:1	10	10	25	25
	10	10	25	25
Area Ratio	50-year design		100-year design	
	Main Stream	Tributary	Main Stream	Tributary
10,000:1	2	50	2	100
	50	2	100	2
1,000:1	5	50	10	100
	50	5	100	10
100:1	10	50	25	100
	50	10	100	25
10:1	25	50	50	100
	50	25	100	50
1:1	50	50	100	100
	50	50	100	100

\*Frequencies provided in **Table 4-13** are based on the iSWM™ *Hydraulics Technical Manual* dated April 2010 and revised September 2014. The current edition shall be used.

- c. The minimum outlet water surface elevation,  $y_m$ , is derived from the following equations:

$$y_m = \frac{D_o + y_c}{2} + FL$$

Where:

- $y_m$  = minimum water surface elevation of the outlet pipe (feet msl)
- $D_o$  = diameter of the outlet pipe (feet)
- $y_c$  = critical flow depth in the outlet pipe (feet)
- $FL$  = flowline elevation of the outlet pipe (feet msl)

- d. Critical flow occurs when the Froude Number is equal to 1. The critical depth,  $y_c$ , is determined by the following equation and solved for depth:

$$Fr = 1.0 = \frac{V_c}{\sqrt{gD_c}}$$

Where:

- $Fr$  = Froude Number
- $V_c$  = flow velocity for critical flow (feet per second)  $V_c = Q/A$ .
- $D_c$  = hydraulic depth at critical flow (feet)
- $g$  = acceleration due to gravity, 32.2 (feet per second squared)

- e. For rectangular channels the hydraulic depth is equal to the flow depth. For other channel geometries, hydraulic depth can be computed by the following equation:

$$D_h = \frac{A}{T}$$

Where:

- $D_h$  = hydraulic depth (feet)
- $A$  = flow area (square feet)
- $T$  = top width of the flow (feet)

2. Friction Losses – For circular storm drains flowing full, Manning’s Equation becomes:

$$Q = \frac{0.46}{n} (D)^{8/3} (S)^{1/2}$$

$$V = \frac{0.59}{n} (D)^{2/3} (S)^{1/2}$$

Where:

- Q = flow in the conduit (cubic feet per second)
- V = velocity of the flow in the conduit (feet per second)
- n = Manning's roughness coefficient from **Table 4-10** (dimensionless)
- S = slope of the conduit in the direction of flow (feet per foot)
- D = storm drain diameter (square feet)

- a. The major loss in a storm drainage system is the friction or boundary shear loss. The head loss due to friction in a pipe is computed as follows:

$$H_f = S_f L$$

Where:

- $H_f$  = friction loss (feet)
- $S_f$  = friction slope (feet per foot)
- L = length of pipe (feet)

- b. The friction slope is also the slope of the hydraulic gradient for a particular pipe run. The friction loss is simply the hydraulic gradient multiplied by the length of the run. Since this design procedure assumes steady uniform flow in open channel flow, the friction slope will match the pipe slope for partial flow. Pipe friction losses for full flow can be determined as follows:

$$S_f = \frac{H_f}{L} = \left( \frac{Qn}{K_Q(D)^{8/3}} \right)^2$$

Where:

- $H_f$  = friction loss (feet)
- L = length of pipe (feet)
- Q = flow in the conduit (cubic feet per second)
- n = Manning's roughness coefficient from **Table 4-10**
- $K_Q$  = coefficient of 0.46 (dimensionless)
- D = storm drain diameter (feet)

3. Minor Losses – There are five types of minor losses that must be considered in hydraulic calculations: exit losses, junction losses, bend losses, transition losses and inlet losses.

- a. Exit Losses – The exit loss from a storm drain outlet is a function of the change in velocity at the outlet of the pipe. For a sudden expansion such as an endwall, the exit loss is:

$$H_x = 1.0 \left( \frac{(V_2)^2}{2g} - \frac{(V_1)^2}{2g} \right)$$



Where:

- $H_x$  = head loss incurred at the pipe outlet (feet)
- $V_2$  = average outlet velocity (feet per second)
- $V_1$  = channel velocity downstream of outlet (feet per second)
- $g$  = acceleration due to gravity, 32.2 (feet per second squared)

Note that when  $V_1 = 0$ , as in a reservoir, the exit loss is one velocity head. For part full flow where the pipe outfalls in a channel with water moving in the same direction as the outlet water, the exit loss may be reduced to virtually zero.

- b. Junction Losses, Without a Manhole or Junction Box – Junction losses incurred when a lateral or trunk line flows into a trunk line without the use of a manhole or junction box as shown in **Figure 4-8** shall be computed using the following equation:

$$H_j = \frac{(Q_o V_o) - (Q_i V_i) - (Q_l V_l \cos \theta)}{0.5 g (A_o + A_i)} + h_i - h_o$$

Where:

- $H_j$  = head loss incurred in junction (feet)
- $Q_o, Q_i, Q_l$  = outlet, inlet, and lateral flows (cubic feet per second)
- $V_o, V_i, V_l$  = outlet, inlet, and lateral velocities (feet per second)
- $h_o, h_i$  = outlet and inlet velocity heads (feet)
- $A_o, A_i$  = outlet and inlet cross-sectional areas (square feet)
- $\theta$  = angle between the inflow and outflow pipes (degrees)

Note that  $V_i, V_l$ , and  $h_i$  will need to be determined by an iterative process. The line for which losses are being calculated will be the inlet, and the other lines summed or averaged will be the lateral  $Q_l$  and  $V_l$ , respectively.

- c. Junction Losses with a Manhole or Junction Box – Junction losses are also incurred when a lateral or trunk line flows into a trunk line, concurrent with the use of a manhole or junction box. A manhole with a main line and one lateral is shown in **Figure 4-9**. The losses are calculated separately for each contributing line and lateral, and in this way, multiple lines and laterals can be added at a manhole or junction box. The losses for each line or lateral shall be computed using the following equations:

$$H_j = K_j \left( \frac{(V_o)^2}{2g} \right)$$

Where:

- $H_j$  = head loss incurred in the junction (feet)
- $K_j$  = adjusted loss coefficient, as shown in **Table 4-14** (dimensionless)
- $V_o$  = velocity of the flow in the outlet pipe (feet per second)
- $g$  = acceleration due to gravity, 32.2 (feet per second squared)

**Table 4-14 – Head Loss Coefficients**

Structure Configuration	$K_j$
Inlet – Straight run	0.5
Inlet – Angled through	
90°	1.5
60°	1.3
45°	1.1
22.5°	0.7
Manhole – Straight run	0.2
Manhole – Angled through	
90°	1
60°	0.9
45°	0.8
22.5°	0.5

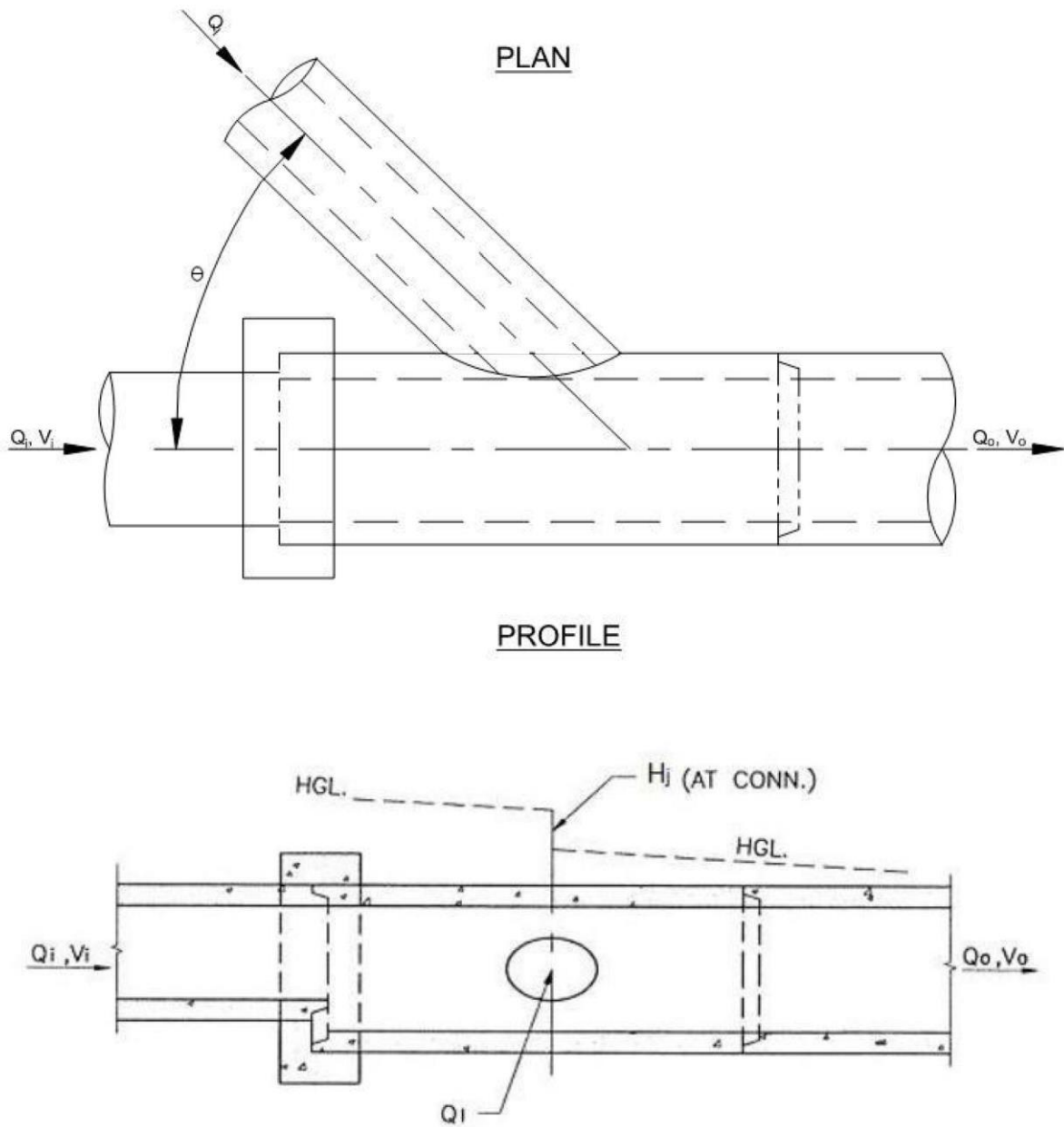


Figure 4-8 – Junction Losses Without a Manhole or Junction Box

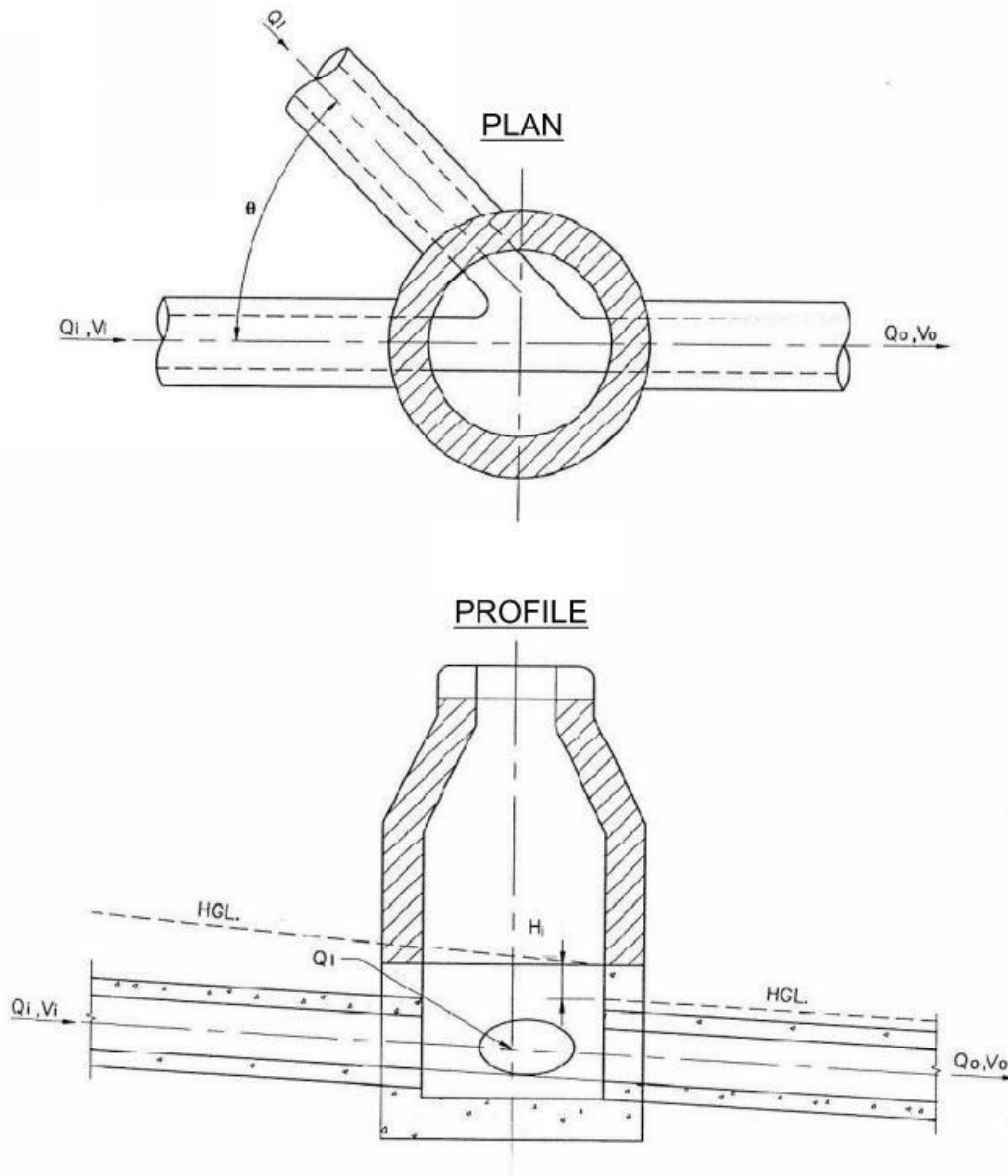


Figure 4-9 – Junction Losses with a Manhole or Junction Box

- d. Losses in a Bend – The head loss at pipe bends is minor, and can be computed using the following equation:

$$h_b = 0.0033\theta \left( \frac{(V_o)^2}{2g} \right)$$

Where:

- $h_b$  = head loss at the bend (feet)
- $\theta$  = angle of bend (degrees)
- $V_o$  = velocity of the flow in the outlet pipe (feet per second)
- $g$  = acceleration due to gravity, 32.2 (feet per second squared)

- e. Losses Due to Transitions (Sudden Expansion or Contraction) – The head losses due to enlargements and contractions in non-pressure flow are calculated using the following equations comparing the kinetic energy at the two ends:

$$H_c = K_c \left( \frac{(V_2)^2}{2g} - \frac{(V_1)^2}{2g} \right)$$

$$H_e = K_e \left( \frac{(V_2)^2}{2g} - \frac{(V_1)^2}{2g} \right)$$

Where:

- $H_c$  = head loss incurred at the contraction (feet)
- $H_e$  = head loss incurred at the expansion (feet)
- $K_c$  = contraction coefficient from **Table 4-15** (dimensionless)
- $K_e$  = expansion coefficient from **Table 4-16** (dimensionless)
- $V_1$  = velocity of the flow upstream of the transition (feet per second)
- $V_2$  = velocity of the flow downstream of the transition (feet per second)
- $g$  = acceleration due to gravity, 32.2 (feet per second squared)

**Table 4-15 – Typical Values for  $K_c$   
Sudden Pipe Contraction in Non-Pressure Flow**

D2/D1	$K_c$
0.2	0.5
0.4	0.4
0.6	0.3
0.8	0.1
1.0	0.0
D <sub>2</sub> /D <sub>1</sub> = Ratio of diameter of smaller pipe to larger pipe	

**Table 4-16 – Typical Values for  $K_e$   
Gradual Pipe Enlargement in Non-Pressure Flow**

D2/D1	Angle of Cone						
	10°	20°	45°	60°	90°	120°	180°
1.5	0.17	0.40	1.06	1.21	1.14	1.07	1.00
3.0	0.17	0.40	0.86	1.02	1.06	1.04	1.00

Note: For gradual contraction,  $K_c = 0.5 K_e$

The head losses due to enlargements and contractions in pressure flow are calculated using the following equations while referencing **Tables 4-17, 4-18, and 4-19** and **Figure 4-10**:

$$H_c = K_c \left( \frac{(V_2)^2}{2g} \right)$$

$$H_e = K_e \left( \frac{(V_1)^2}{2g} \right)$$

Where:

- $H_c$  = head loss incurred at the contraction (feet)
- $H_e$  = head loss incurred at the expansion (feet)
- $K_c$  = contraction coefficient (dimensionless)
- $K_e$  = expansion coefficient (dimensionless)
- $V_1$  = velocity of the flow upstream of the transition (feet per second)
- $V_2$  = velocity of the flow downstream of the transition (feet per second)
- $g$  = acceleration due to gravity, 32.2 (feet per second squared)

**Table 4-17 – Typical Values for  $K_e$   
Gradual Pipe Enlargement in Pressure Flow**

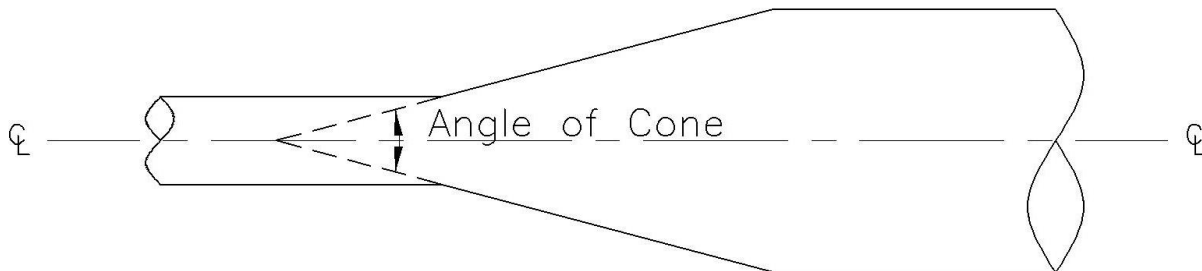
D2/D1	Angle of Cone										
	2°	6°	10°	15°	20°	25°	30°	35°	40°	50°	60°
1.1	0.01	0.01	0.03	0.05	0.10	0.13	0.16	0.18	0.19	0.21	0.23
1.2	0.02	0.02	0.04	0.09	0.16	0.21	0.25	0.29	0.31	0.35	0.37
1.4	0.02	0.03	0.06	0.12	0.23	0.30	0.36	0.41	0.44	0.50	0.53
1.6	0.03	0.04	0.07	0.14	0.26	0.35	0.42	0.47	0.51	0.57	0.61
1.5	0.03	0.04	0.07	0.15	0.28	0.37	0.44	0.50	0.54	0.61	0.65
2.0	0.03	0.04	0.07	0.16	0.29	0.38	0.46	0.52	0.56	0.63	0.68
2.5	0.03	0.04	0.08	0.16	0.30	0.39	0.48	0.54	0.58	0.65	0.70
3.0	0.03	0.04	0.08	0.16	0.31	0.40	0.48	0.55	0.59	0.66	0.71

**Table 4-18 – Typical Values for  $K_c$   
Sudden Pipe Contractions in Pressure Flow**

D2/D1	Velocity (feet per second)							
	2.0	4.0	6.0	8.0	10.0	20.0	30.0	40.0
1.1	0.03	0.04	0.04	0.04	0.04	0.05	0.05	0.06
1.4	0.17	0.17	0.17	0.17	0.18	0.18	0.19	0.20
1.8	0.34	0.34	0.34	0.33	0.33	0.32	0.29	0.27
2.2	0.40	0.40	0.39	0.39	0.38	0.35	0.33	0.30
3.0	0.44	0.44	0.43	0.42	0.42	0.39	0.36	0.33
5.0	0.48	0.48	0.48	0.47	0.46	0.43	0.40	0.36
10.0	0.49	0.48	0.48	0.47	0.47	0.44	0.41	0.38

**Table 4-19 – Typical Values for  $K_e$   
 Sudden Pipe Enlargement in Pressure Flow**

D2/D1	Velocity (feet per second)							
	2.0	4.0	6.0	8.0	10.0	20.0	30.0	40.0
1.2	0.11	0.10	0.10	0.10	0.09	0.09	0.09	0.08
1.4	0.26	.025	0.24	0.24	0.23	0.22	0.21	0.20
1.6	0.40	0.38	0.37	0.366	0.35	0.33	0.32	0.32
2.0	0.60	0.56	0.55	0.53	0.52	0.50	0.48	0.47
3.0	0.83	0.78	0.76	0.74	0.73	0.69	0.67	0.65
5.0	0.96	0.91	0.88	0.86	0.84	0.80	0.77	0.75
10.0	1.00	0.96	0.93	0.91	0.89	0.84	0.82	0.80



**Figure 4-10 – Angle of Concentration for Pipe Diameter Changes**

- f. Inlet Losses – Inlet losses, which occur at all inlets located at the upstream end of pipe systems, as shown in **Figure 4-11**, shall be computed as follows:

$$H_i = K_i \left( \frac{(V_o)^2}{2g} \right)$$

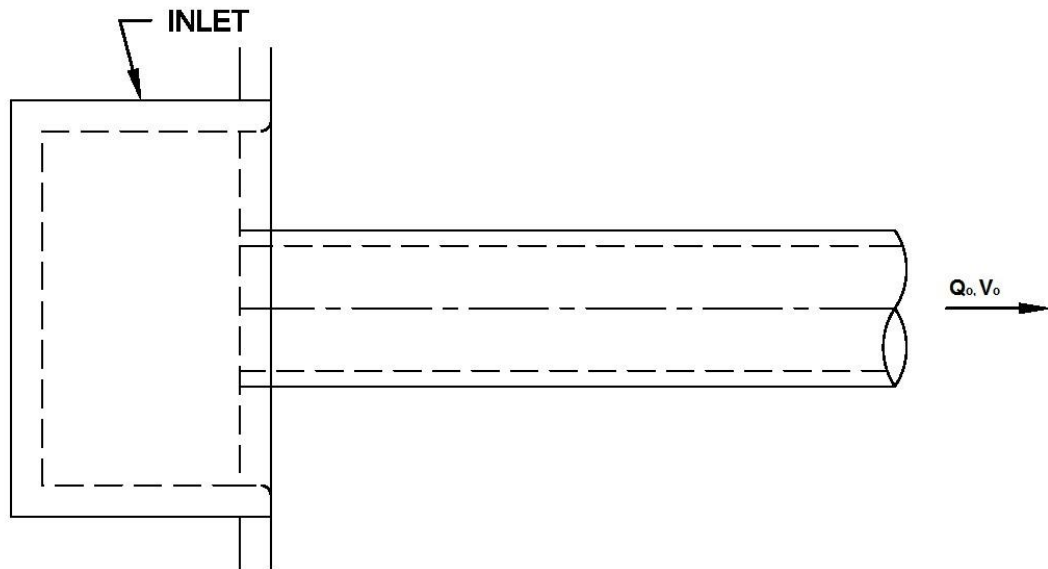
Where:

- $H_i$  = head loss incurred at the inlet (feet)
- $K_i$  = loss coefficient, 1.25 (dimensionless)
- $V_o$  = flow velocity in the outlet pipe (feet per second)
- $g$  = acceleration due to gravity, 32.2 (feet per second squared)

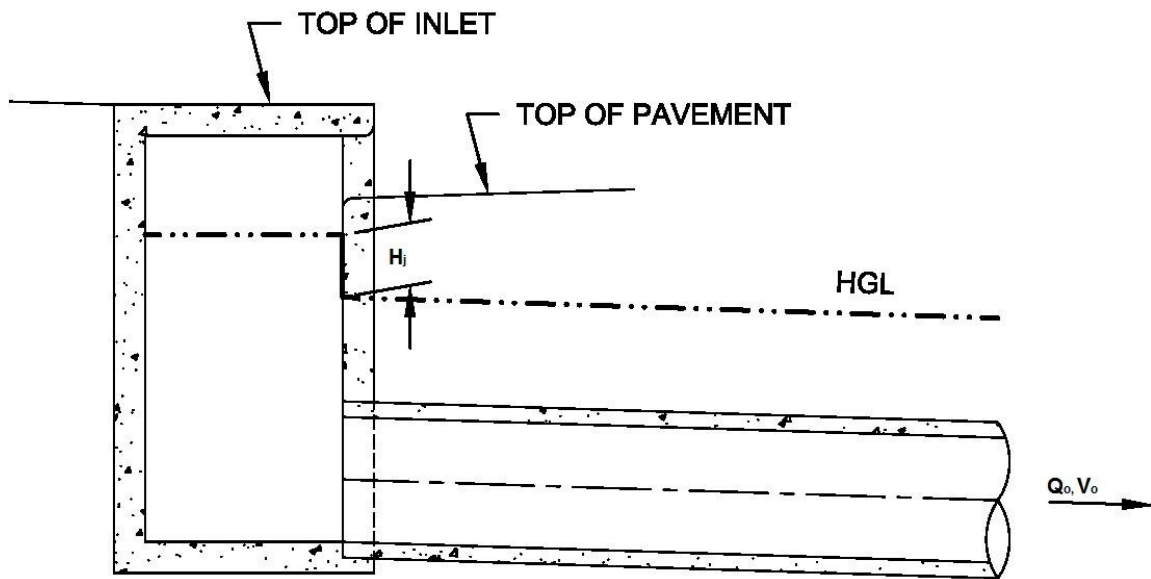
- i. It should be noted, however, that this equation only applies to pipes in pressure flow. Partial flow, especially in very steep pipes, can produce very high flow velocities where this equation would not be applicable. This may be true even for very small flow rates. For partial flow, a lower value of  $K_i$  may be used with approval from the Director of Engineering.

- g. Pipe Outfalls – See **Sections 4.7.B** and **4.8** for outfall design criteria.





PLAN



PROFILE

Figure 4-11 – Inlet Losses

## 4.8. Open Channels

### 4.8.A. Applicable Design Criteria

1. All constructed channel improvements shall be designed in accordance with the guidelines set forth in the Stream Bank Stabilization Manual, the City of McKinney Stormwater Management Ordinance, FEMA guidelines, and any individual creek master plans that have been completed. Unless approved by the Director of Engineering, open channels shall not be permitted when the inside pipe diameter required to carry the fully developed 100-year flow is 60 inches or less. Exceptions to this would be residential estate subdivisions and other areas where there are significant natural features, including trees, springs, exposed channels, and other environmental items that would work positively into the aesthetics of a development. All other applicable design criteria not listed in this section shall be in accordance with the current edition of the NCTCOG iSWM™ *Technical Manual*.
2. The City encourages the use of natural channels when possible. When a natural channel is not feasible, the use of a pipe system or a grass lined channel is preferred. If a grass lined channel is proposed, the City requires that the HOA or POA submit a maintenance agreement to the City to ensure the proposed channel will be maintained in perpetuity. Also note that developers are responsible for acquisition of all state and federal regulatory agency permits and approvals.
3. The developer shall be responsible for the initial (one time) channel modifications, to include the replacement of trees at the direction of the City, and as required by State and Federal agencies. Initial (one time) selective clearing of debris, small trees, brush, vines, etc. from floodways and floodplains of channels shall be the responsibility of the developer as allowed by the current permitting requirements. In addition, the developer may dedicate the floodway and/or floodplain as a deed-restricted greenbelt area. Dedication of floodways/floodplains as greenbelts does not necessarily preclude open space requirements as set forth in the applicable subdivision ordinances of the City.

### 4.8.B. Design Parameters – In addition to the criteria listed above, there are several general design guidelines to be observed:

1. Refer to **Section 4.2** for criteria regarding additional floodplain development criteria.
2. Boundary Conditions – The downstream starting water surface elevation shall be normal depth for all standard step backwater calculations. Some exceptions may apply to set the downstream boundary condition at a known water surface elevation based on a FEMA FIS profile, backwater elevation, or City effective model output. Refer to **Table 4-13** for frequencies for coincidental occurrences.

3. Design Frequency and Freeboard – Refer to **Table 4-3** in **Section 4.4** for design frequency and freeboard requirements. If the design flow for a given channel, bridge, or culvert cannot be obtained by reference to a previous study, the procedures described in **Section 4.4** shall be used to determine the design flows.
4. Roughness Coefficients and Allowable Velocities
  - a. Where possible, channels shall be designed have sufficient gradient to provide velocities that will be self-cleaning and not cause erosion. No changes shall be made to a channel that will cause the velocity to exceed the values listed in **Table 4-20**. These values are listed as maximums under normal conditions. Refer to **Table 4-12** in **Section 4.6** for maximum storm drain pipe outfall velocities into channels. The Streambank Stabilization Manual provides further detail on erosive velocities in channels.
  - b. Refer to **Table 4-20** for appropriate Manning's n values. Manning's n values shall assume the unmaintained condition.
  - c. The Director of Engineering reserves the right to require safety fencing or other protective measures.
  - d. In unlined channels, velocity reduction factors for winding channels are 5 percent for slightly sinuous channels, 13 percent for moderately sinuous channels, and 22 percent for very sinuous channels.
  - e. Unlined channels with bends shall be designed to minimize erosion at the bends, and erosion protection shall be designed based on the velocity along the outside of the channel bend.
5. Energy Dissipators – Appropriate energy dissipating or grade control structures may be used to control erosion due to high velocities at pipe and channel system outfalls, and they shall be designed in accordance with accepted design practice such as outlined by the NRCS, the USACE, the Bureau of Land Reclamation, or the Texas Department of Transportation (TxDOT). The design of energy dissipators shall be based on a geotechnical investigation of the site. Maximum velocities shall be checked for both the 5-year and 100-year frequency storm events for both tributary and receiving water with protection provided for the most critical combination(s).
6. Side Slopes – Improved or constructed channels shall have side slopes no steeper than 4H:1V for unlined channels and no steeper than 2H:1V for lined channels.
7. Channel Geometry – Improved channels, line or unlined, shall normally have a trapezoidal cross section. The channel section should have adequate flow area to handle uncertainties in runoff estimates, seasonal changes in channel roughness coefficients, channel obstructions, and silt accumulation.

**Table 4-20 – Roughness Coefficients and Allowable Velocities for Channels**

Channel Description	Manning's n	Maximum Permissible Channel Velocity (feet per second)
<b>NATURAL STREAMS</b>		
<b>Floodplain – Pasture</b>		
Short grass	0.030	6.0
Tall grass	0.035	6.0
<b>Floodplain – Cultivated Areas</b>		
No crop	0.030	6.0
Mature row crops	0.035	6.0
Mature field crops	0.040	6.0
<b>Floodplain – Uncleared</b>		
Heavy weeds scattered brush	0.050	6.0
Wooded	0.120	6.0
<b>UNLINED NON-VEGETATED CHANNELS</b>		
Sand/Silt	0.030	3.0
Clay	0.030	5.0
Coarse Gravel	0.030	6.0
Shale	0.030	10.0
Rock	0.025	15.0
<b>LINED CHANNELS</b>		
Concrete	0.013	20.0
Grouted Riprap	0.030	*
Rock Riprap	0.040	*
Stone Masonry	0.032	10.0
Asphalt	0.016	15.0
Gabion	0.030	12.0

\*Maximum permissible velocities for rock riprap based on gradation and depth.

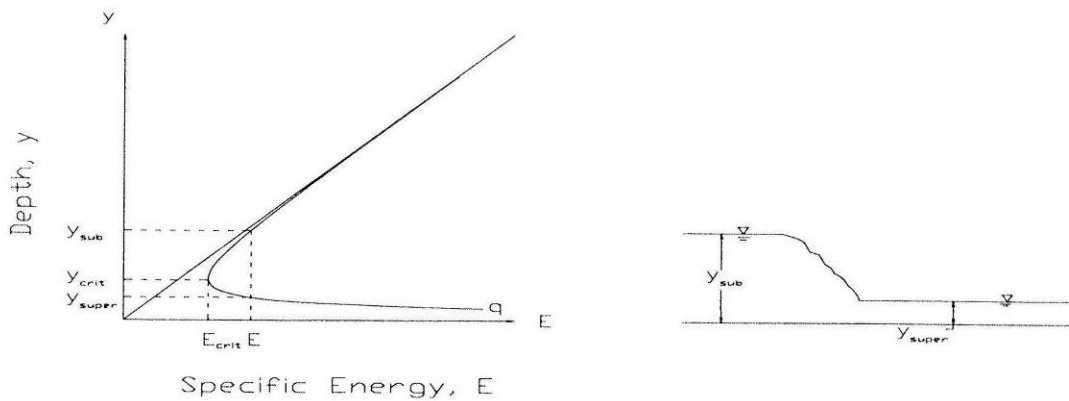
4.8.C. Flow Conditions – The Froude Number provides a relationship between flow velocity and the hydraulic depth of flow and gravitational action and shall be calculated for all channel improvement designs. Subcritical flow conditions occur when the Froude number is less than 1.0, and supercritical flow conditions exist in lined channels when the Froude Number exceeds 1.0. The Froude number may be calculated by the following equations:

$$Fr = \frac{V}{\sqrt{gD}}$$

$$D = \frac{A}{T}$$

Where:

- V = velocity of flow (feet per second)
- g = acceleration due to gravity (feet per second squared)
- D = hydraulic depth (feet)
- A = cross-sectional area of the flow (square feet)
- T = top width of the flow (feet)



$$E = \frac{V_{sub}^2}{(2g)} + y_{sub} = \frac{V_{super}^2}{(2g)} + y_{super}$$

**Figure 4-12 – Alternate Depths on the Specific Energy Curve**

1. Each channel cross section has two flow depths, the normal depth and the alternate depth. Although the depths, velocities, and Froude Number differ, the specific energy of the two depths is equivalent. **Figure 4-12** shows the relationship of specific energy to depth. If a channel's normal depth is supercritical, its alternate depth is a deeper subcritical depth. Obstructions that may enter a stream during a storm event may cause supercritical flows to experience a hydraulic jump and become subcritical flows. Due to this fact, channels that are designed for supercritical conditions must have freeboard equal to the alternate depth plus one foot.
2. Subcritical flow conditions are recommended for all channel designs in the City. Supercritical flow tends to have high velocities and high potential for channel erosion. Supercritical flow conditions shall not be allowed in unlined channels except at grade control structures. Subcritical flow conditions may be achieved by using energy dissipaters in unlined channels in areas where the existing topography will not allow subcritical flow conditions to occur naturally. In all cases, the channel improvements shall be designed to avoid the unstable transitional flow conditions that occur when the Froude Number is between 0.9 and 1.1 unless analyses demonstrate that no adverse impacts will occur as a result.

- 4.8.D. Flow in Bends – When a channel changes direction, the depth of flow and shear stresses along the outside edge of the curve are higher than the average channel flow depth, or the water surface is super-elevated. Therefore, additional freeboard and armoring must be provided to prevent the channel bank from being overtopped or eroded. The amount of superelevation along the outside of the bend can be estimated using the equation:

$$\Delta H = \frac{C^2}{2g(r_o)^2(r_i)^2} \left( (r_o)^2 - (r_i)^2 \right)$$

Where:

- $\Delta H$  = increase in water surface elevation along the outside of the channel bend due to superelevation (feet)
- $C$  = circulation constant (square feet per second)
- $r_o$  = outside radius of the channel bend (feet)
- $r_i$  = inside radius of the channel bend (feet)
- $g$  = acceleration due to gravity, 32.2 (feet per second squared)

1. If the discharge, depth of flow at the approach to the bend, average flow velocity in the approach to the bend, and the inner and outer radii of the bend are known, the value of the circulation constant can be approximated by solving the follow equation for  $C$ :

$$Q = C \left[ y_a + \frac{(V_a)^2}{2g} - \frac{C^2}{2gr_o r_i} \right] \ln \left( \frac{r_o}{r_i} \right)$$

Where:

- $Q$  = total flow in the channel (cubic feet per second)
- $V_a$  = average velocity in the approach to the bend (feet per second)
- $y_a$  = depth of flow in the approach to the bend (feet)

2. The flow velocity along the outside of the bend,  $V_o$  (feet per second), can then be approximated by:

$$V_o = \frac{C}{r_o}$$

$V_o$  shall not exceed the maximum values established in **Table 4-20**. See Stream Bank Stabilization Manual for analyses methodology and treatment solutions for bends in unlined channels.

- 4.8.E. Drop Structures – The function of a drop structure is to reduce flow velocities by dissipating some of the kinetic energy of the flow at the drop structure and also providing flatter channel slopes upstream and downstream of the drop structure. Drop structures may be used to establish or re-establish a more desirable channel invert elevation and slope. Sloping channel drops and vertical channel drops are two commonly used drop structure types. Flow velocities in the channel upstream and downstream of the drop structure shall satisfy the permissible velocities allowed for

channels (**Table 4-20**). Flow velocities shall be checked for runoff produced by the 5-year and 100-year frequency storm events. Refer to **Section 6** for structural design requirements.

1. Vertical Drop Structures – The drop structure should have sufficient height to stabilize the hydraulic jump. The drop length and the hydraulic jump length of the drop structure should be calculated to determine the length of the downstream apron required to prevent erosion. In order to utilize a vertical drop structure, vehicular access must be provided to both the upstream and downstream ends of the structure.
  2. Sloping Drop Structures – The location of the hydraulic jump should be determined based on the upstream and downstream flow depths and channel slopes. The length of the hydraulic jump should be calculated to determine the length of the downstream apron required to prevent erosion. When utilizing a sloping drop structure, a maximum slope of 8H:1V shall be used to allow vehicular access from one end across the structure. If the slope of the drop structure is steeper than 8H:1V, vehicular access must be provided to both the upstream and downstream ends of the structure.
- 4.8.F. Rock Riprap – Rock and grouted riprap may be used. Rock riprap gradation depends on site characteristics, velocities, and flow depth. One of the following methods shall be used for determining a nominal rock riprap size and gradation: USACE 1110-2-1601, FHWA HEC-11, or Gregory Method from the current edition of the iSWM™ *Hydraulics Technical Manual*.
- 4.8.G. Maintenance Access Requirements - Unobstructed access routes shall be provided to all natural and improved open channels and creeks to allow vehicular access for maintenance. This shall include all areas that are otherwise cutoff by tributaries, steep banks, or other obstructions. All portions of the maintenance access routes shall be located entirely within drainage easements associated with the creek or channel. The unobstructed access shall extend from the ROW and occur at a frequency of no less than 1,500 linear feet along the channel unless there exists an access route that is contained within a drainage easement on the opposite side of the creek or channel. This may be adjusted by no more than 100 feet to lessen impacts to quality trees or to avoid restrictive slopes. Access routes along open channels and to/from the ROW shall be a minimum of 15 feet wide with a maximum 8H:1V running slope and a maximum 10H:1V cross slope. Access routes shall be kept clear of structures and other equipment, such as HVAC units. Fences are allowed within drainage easements only if they do not block the flow of surface runoff. Also, a 16-foot wide gate (locks to be provided by the City) shall be provided at all fence locations that block vehicular maintenance access routes.
- 4.8.H. Calculations – Water surface profiles for each design storm shall be computed for all channels and shown on all final drawings. The Standard Step Method for Backwater Calculations shall be used to determine water surface profiles for steady uniform flow equal to the design discharge. HEC-RAS by USACE may be used to perform standard step backwater calculations, and if used, a summary table shall be provided. Losses due to changes in velocity, drops, bridge openings, and other



obstructions shall be considered in backwater computations, as described in the HEC-RAS *User's Manual*.

#### 4.9. Bridge and Culvert Hydraulic Design

4.9.A. Applicable Design Criteria – Bridges and Culverts shall be designed based on the frequency and freeboard requirements found in **Table 4-3** in **Section 4.4**. In addition to the freeboard requirements above, consideration shall be given to existing and/or proposed development upstream of the structure. Refer to **Section 6** for structural design requirements.

1. All bridge and culvert designs shall contain the peak flow design event based on **Table 4-3** within the ROW or drainage easement limits.
2. Headwalls and necessary erosion protection shall be provided at all culverts and shall comply with the most current Texas Department of Transportation (TxDOT) standards.
3. Proposed reinforced concrete box culverts, bridges, and related structures may be adaptations of TxDOT standards. Refer to **Section 6** for structural design requirements.
4. All bridges and culverts shall be designed so that if they become partially or completely blocked they will not divert flow from the natural or designed flow path or cause damage to the structure and other property.
5. Projected changes in channel stability upstream and downstream of the structure shall be evaluated using the methods presented in the Stream Bank Stabilization Manual when establishing the structure type, channel grades, and crossing geometry. Appropriate stabilization measures are required.
6. If designed for flows less than the fully developed 100-year peak discharge, the engineer shall demonstrate that flows exceeding the bridge's hydraulic capacity will not be diverted out of the floodplain or cause damage to upstream, downstream, or adjacent property as a result of bridge construction.
7. All roadway drainage shall be carried to the bridge ends and collected in a closed storm sewer system. If deck drains are required, due to structural length and hydraulic capacity, they shall discharge to downspout and a properly designed splash basin or closed storm sewer system to minimize erosion. Drainage shall not discharge against any part of the structure.
8. A scour analysis is required for all structural elements within the design floodplain.

4.9.B. Design Parameters – The designer should begin with the culvert or bridge design from the nearest downstream control, such as a bridge, culvert, or dam, and design the proposed drainage system improvements anticipating future system expansion and stream stability changes due to fully developed watershed conditions. The most commonly used backwater program for modeling hydraulic conditions at bridge



crossings is the HEC-RAS program developed by the USACE. Several hydraulic parameters should be considered in bridge design. These considerations include, but are not limited to, the following:

1. Channel transitions into and out of the bridge opening.
  2. Overall length and height of bridge.
  3. Cross-sectional opening of bridge.
  4. Bridge alignment relative to general flow of main channel such as a skewed crossing.
  5. Number of crossings (dual or multiple bridges).
  6. Other obstructions to flow (piers and abutments).
  7. Design flows for bridge opening to pass the design flow.
  8. Freeboard requirements for channel design.
  9. Erosion protection at piers and abutments (based on local and system stability changes).
  10. Potential flooding impacts on property and threat to loss of life of partial and complete blockage shall be considered.
  11. Possible damages to the structure or other property due to flows in excess of the fully developed 100-year storm event.
- 4.9.C. Culvert Outlet Protection – High discharge velocities from culverts can cause eddies or other turbulence that could damage unprotected downstream channel banks and roadway embankments. To prevent damage from scour and erosion in these conditions, culvert outlet protection is needed. Scour protection in accordance with FHWA *HEC-18 Evaluation of Scour at Bridges*, or equivalent, shall be provided.
1. The outlet protection should extend downstream to a point where non-erosive channel velocities are established in accordance with **Table 4-20**. The outlet protection should be placed sufficiently high on the adjacent banks to provide protection from wave wash under design flow conditions and be provided with sufficient cutoff (scour) protection at the downstream edge based on local scour calculations and downstream channel stability investigation.
  2. The critical depth shall be used to determine exit velocity and associated erosion control measures for a culvert with low tailwater. Refer to **Section 4.8.B** for erosion control requirements.
  3. Refer to **Section 4.8.F** for rock riprap sizing methods.
- 4.9.D. Minimum driveway culvert diameter shall be 18 inches unless otherwise approved by the Director of Engineering. Driveway culvert material shall be reinforced concrete unless otherwise approved by the Director of Engineering.
- 4.9.E. Culvert Hydraulics – The hydraulic design of culverts shall be based upon design guidelines set forth by TxDOT, the U.S. Department of Transportation, or other

suitable material as approved by the Director of Engineering. **Table 4-21** contains the culvert entrance loss coefficients ( $K_e$ ) to use. Culvert calculations shall be provided to the City for review. Calculations shall include, but are not limited to, headwall, tailwater, and flowline elevations, lowest adjacent grade and structure elevations, inlet and outlet control calculations, and velocity calculations.

**Table 4-21 – Culvert Entrance Loss Coefficients**

Type of Culvert	$K_e$
<b>Reinforced Concrete Pipe</b>	
projecting from fill, socket end (groove end)	0.2
projecting from fill, square cut end	0.5
headwall or headwall with wingwalls	
socket end of pipe (groove end)	0.2
square edge	0.5
rounded edge (radius $\geq 0.0833D$ )	0.2
mitered to conform to fill slope	0.7
beveled edges, 33.7° or 45° bevels	0.2
side or slope tapered inlet	0.2
<b>Corrugated Metal Pipe or Arch-Pipe:</b>	
projecting from fill (no headwall)	0.9
headwall or headwall with wingwalls, square edge	0.5
mitered to conform to fill slope, paved or unpaved slope	0.7
beveled edges, 33.7° or 45° bevels	0.2
side or slope tapered inlet	0.2
<b>Reinforced Concrete Box:</b>	
headwall parallel to embankment (no wingwalls)	
square-edged on three sides	0.5
rounded on three sides to radius of 1/12 barrel dimension or beveled edges on three sides	0.2
wingwalls at 30°-70° to barrel	
square-edged at crown	0.4
crown edge rounded to radius of 1/12 barrel dimension, or beveled top edge	0.2
wingwall at 10°-25° to barrel, square-edged at crown	0.5
wingwalls parallel (extension of sides), square-edged at crown	0.7
side or slope-tapered inlet	0.2

#### **4.10. Detention Basin Design**

4.10.A. Determination of Required Detention – The City of McKinney Stormwater Management Ordinance outlines the criteria for when detention is needed. The following is a summary of those criteria. In the case that this manual and the Unified Development Code conflict, the Unified Development Code will take precedence.

1. New development in McKinney shall follow the 10% rule as defined by the integrated stormwater management (iSWM™) manual published by the North Central Texas Council of Governments (NCTCOG). Refer to the latest edition of this manual for additional information.
  - a. Downstream assessments are unnecessary if a development is less than 5% of the overall watershed at the outfall of the development.
  - b. If the study determines that the necessary capacity with appropriate freeboard does not exist, the developer must construct the improvements to provide the necessary capacity or provide on-site detention facilities.
  - c. If the study determines that the drainage and/or floodplain easements do not exist, the developer must obtain the necessary easements, or provide on-site detention facilities.
  - d. Typical steps in a downstream assessment include:
    - i. Determine the outfall location(s) of the site and the pre-development and post-development site conditions.
    - ii. Using a topographic map determine a preliminary lower limit of the zone of influence (at the next junction beyond the 10% point).
    - iii. Using a hydrologic model determine the pre-development peak flows at each junction beginning at the development outfall(s) and ending at the next junction beyond the 10% point. Undeveloped off-site areas are modeled as “fully developed” for both the pre-development and post-development analyses. Evaluate the discharge of the 5-year and 100-year fully developed storms.
    - iv. Change the land use on the site to post-development conditions and rerun the model.
    - v. Compare the pre-development and post-development peak discharges at the downstream end of the model. If the post-developed flows are higher than the pre-developed flows, extend the model downstream. Repeat steps 3 and 4 until the post-development flows are less than the pre-developed flows or until the development is less than 5% of the overall watershed being analyzed, whichever comes first.
2. A downstream assessment may be required if the Director of Engineering has reason to believe that on-site detention may increase the fully developed 100-

year peak flow due to coincidental peaks. If the assessment demonstrates coincidental peaks, on-site detention facilities will not be an acceptable option. Downstream improvements may be required if downstream capacity and easements are inadequate to convey the increased site flow. This will be determined by the Director of Engineering on a case-by-case basis.

#### 4.10.B. Applicable Design Criteria

1. Stormwater detention basins are used to temporarily impound (detain) stormwater, thereby reducing peak discharge rates. Either regional or on-site detention/retention basins may be used to provide required detention. Detailed hydrologic studies of the entire watershed upstream of the detention site shall be required to evaluate the timing of inflow and outflow hydrographs from both regional and on-site detention facilities.
2. Basins without large, regional upstream detention facilities and with drainage areas of 50 acres or less may be designed using the Modified Rational Method, as described in **Section 4.4** and **4.10.C** of this manual. Basins with drainage areas greater than 50 acres, or where the Modified Rational Method is not appropriate or applicable, shall be designed using the Unit Hydrograph Method. The routing of a hydrograph through a detention basin shall be done using standard pond routing techniques, such as the Modified Puls method. Acceptable hydrology modeling computer programs include HEC-1, HEC-HMS, and TR-20. Other hydrology modeling computer programs may also be used with the approval of the Director of Engineering.
3. All detention basin designs shall be performed by an engineer licensed in the State of Texas and experienced in detention basin design. The following criteria shall serve as minimum requirements for detention basin design in the City:
  - a. The 100-year storm event based on fully developed watershed conditions shall be used to determine the total volume of detention storage required. In addition, the outlet structure shall be designed to control both the 100-year storm and the 5-year storm to pre-project levels. Freeboard must meet the requirements in **Table 4-3** in **Section 4.4**.
  - b. The design shall meet the minimum requirements of State and Federal regulations and guidelines.
  - c. A non-erodible emergency spillway or overflow pathway shall be provided above the 100-year maximum water surface elevation. If necessary, integrity and stability analyses as described in NRCS TR-60 may be used to demonstrate that an earthen or grass lined earthen spillway is stable and has the required integrity.
  - d. Where the outflow structure conveys flow through the embankment in a conduit, the conduit shall be reinforced concrete and designed to support the external load. The conduit is to withstand the internal hydraulic pressure without leakage under the full external load and must convey water at the design velocity without damage to the interior surface of the conduit. Antiseep

collars or other acceptable piping protection shall be provided for all conduits that discharge through the embankment.

- e. If the outflow structure discharges flows into a natural stream or unlined channels, discharge shall be at a non-erosive rate in accordance with **Section 4.8** of this Manual.
- f. Detention basins shall provide positive drainage throughout the basin with a minimum slope of 2 percent leading to the required pilot channel. The steepest side slope permitted around a detention basin is 4H:1V unless approved by a geotechnical engineer.
- g. A non-erodible pilot channel or conduit shall be provided to convey low flows from points of concentrated inflow to the basin outlet structure. Erosion protection such as open cell pavers, articulate block, rock riprap (see **Section 4.8.F**), or gabion mattress must be provided adjacent to the pilot channel or conduit to prevent undermining due to scour. The pilot channel must have a minimum slope of 0.60 percent. Refer to the Standard Details for pilot channel design requirements.
- h. Earthen embankments used to impound a required detention volume must have a minimum top width of 12 feet, shall contain a non-permeable core, and shall be based on a geotechnical investigation for the site. The geotechnical investigation shall be performed by a licensed engineer and shall include, as a minimum, the type of material on-site, water content, liquid limit, plasticity index, and desired compaction. Earthen embankments shall conform to Chapter 299 of the Texas Administrative Code (TAC) and any other applicable State and Federal dam safety requirements. Refer to **Section 4.12** for further design and permitting details.
- i. It shall be the engineer of record's responsibility to determine if a stability analysis is necessary based on global overturning and rapid drawdown. The stability analysis shall be performed by a licensed geotechnical engineer. Global overturning shall be based on full hydrostatic loading (at 100-year flood stage). The stability analysis from rapid drawdown conditions shall consider saturated soil conditions without the hydrostatic loading. A minimum factor of safety of 1.25 shall be required.
- j. Security fencing with a minimum height of 6 feet may be required to encompass the detention storage area if the location, velocity, depth, or slopes justify restricted access to the general public, as determined by the Director of Engineering. The fence shall be designed to allow access for maintenance, as well as to not restrict stormwater flow into or out of the detention basin.
- k. Ongoing maintenance by the property owner is required if detention facilities are to function properly over time and shall be in accordance with Section 702C of the Stormwater Ordinance. A Maintenance Plan with specific instructions for maintenance over the life of the facility must be submitted with the civil construction plans and approved by the Director of Engineering. At a

minimum, the following maintenance guidelines apply to all detention facilities.

- i. A maintenance ramp shall be provided for vehicular access for maintenance purposes shall meet requirements in **Section 4.8.G**. The slope of the ramp shall not exceed 8H:1V, and the minimum width shall be 12 feet.
- ii. Detention basins with permanent water storage must include dewatering facilities for maintenance purposes.
- iii. The following notes, at a minimum, shall be included on the Post Construction Stormwater Quality Plan Sheet as part of the civil construction plans:
  - a. The property owner shall be responsible for all maintenance of detention facilities.
  - b. Detention facilities shall be mowed at least twice per year to control weeds and inhibit woody growth.
  - c. Debris, litter, and sediment shall be removed from all detention facilities at least twice per year and after each storm event with more than 2 inches of rainfall in a 24 hour period, with particular attention given to the removal of debris, litter, and sediment around outlet structures, trash racks, and pilot channels.
  - d. A maintenance log shall be kept and shall be made available for review by the City upon request.
- iv. The following note shall be included on the plat: **MINIMUM MAINTENANCE REQUIREMENTS FOR DETENTION FACILITIES CAN BE FOUND ON THE POST CONSTRUCTION STORMWATER QUALITY PLAN SHEET AS PART OF THE CIVIL CONSTRUCTION PLANS.**
- l. All applicable permits must be obtained for basins with permanent water storage.
- m. Detention basins located in the 100-year floodplain shall include timing calculations with flood study to verify there is no coincidental peak flow in relation to creek channel.
- n. Commercial and industrial parking areas may be used for detention/retention volume up to a maximum depth of 1 foot, but only for storage volume above what is required for detention of a 5-year storm event.
- o. To minimize both the possibility of clogging and the amount of debris conveyed to area lakes and streams, trash racks may be needed on detention system outlet structures as determined by the Director of

Engineering. The design of trash racks shall be according to the guidelines set forth in the iSWM™ Hydraulics Technical Manual.

#### 4.10.C. Modified Rational Method Detention Basin Calculations

1. The detention volume for a given duration using this method is calculated as the difference between a trapezoidal inflow hydrograph and a triangular outflow hydrograph as shown in **Figure 4-13**. Design must account for all onsite and offsite flows to the discharge point. If flow bypasses the detention basin, the allowable release must be adjusted accordingly. A range of storm durations is required to determine the critical duration for the detention basin.
2. The following is an example of the Modified Rational Method calculations necessary for the sizing of a detention pond:
  - a. GIVEN – A 53.91-acre site, which is currently zoned for agricultural use, is to be developed for Zone RS-60, Single-Family Residence District (6,000 sf lot per unit) subdivision with a Rational Method C of 0.65. Of the whole site, 41.27 acres are to be developed as single-family lots and the remaining 12.64 acres will become a park in which the proposed detention pond will be placed. The park will have a C of 0.40.
  - b. DETERMINE – Maximum release rate and required detention storage.
  - c. SOLUTION –
    - i. Step 1 – Determine 100-year peak runoff rate prior to site development. This is the maximum allowable release rate from the site after development.

$$I_{100} = \frac{b}{(T_c + d)^e} = \frac{86.709}{(26 + 11)^{0.73702}} = 6.06 \text{ inches per hour}$$

Where:

$$I = \frac{b}{(T_c + d)^e}$$

b = 86.709	<b>Table 4-1</b>
d = 11	<b>Table 4-1</b>
e = 0.73702	<b>Table 4-1</b>
T <sub>c</sub> = 26 minutes	Calculated based on <b>Section 4.4.D</b>

$$Q_A = Q_{100} = K_{100} C I_{100} A = 1.15 \times 0.30 \times 6.06 \times 53.91 = 112.71 \text{ cfs}$$

Where:

Q = KCIA	
K = 1.15	<b>Table 4-4</b>
C = 0.30	<b>Table 4-5</b>



- ii. Step 2 – Determine inflow hydrograph for storms of various durations in order to determine maximum volume required with release rate determined in Step 1. Incrementally increase durations to next 10-minute time and increase by 10-minutes for each additional time step to determine maximum required volume. The duration with a peak inflow less than maximum release rate or where required storage is less than storage for the prior duration is the last increment.

$$I_{100} = \frac{b}{(T_c + d)^e} = \frac{86.709}{(18 + 11)^{0.73702}} = 7.25 \text{ inches per hour}$$

Where:

$$I = \frac{b}{(T_c + d)^e}$$

$b = 86.709$       **Table 4-1**  
 $d = 11$             **Table 4-1**  
 $e = 0.73702$       **Table 4-1**  
 $T_c = 18 \text{ minutes}$       Calculated based on **Section 4.4.D**

$$C_w = \frac{A_1 C_1 + A_2 C_2}{A_1 + A_2} = \frac{44.17 \times 0.65 + 12.64 \times 0.40}{44.27 + 9.64} = 0.59$$

Where:

$$C_w = \text{weighted coefficient (dimensionless)}$$

$$Q_{100} = K_{100} C_w I_{100} A = 1.15 \times 0.59 \times 7.25 \times 53.91 = 265.19 \text{ cfs}$$

- iii. Step 3 – Determine Maximum Storage Volume by deducting the volume of runoff released during the time of inflow from the total inflow for each storm duration.
- iv. Step 3A – Calculate the intensity, I, and peak flow, Q, for the various duration storms:

$T_d$	I	$Q_d = K C_w I A$	
18 min	7.25	$1.15 * 0.59 * (7.25) * 53.91 = 265.19$	cfs
20 min	6.90	$1.15 * 0.59 * (6.90) * 53.91 = 252.39$	cfs
30 min	5.62	$1.15 * 0.59 * (5.62) * 53.91 = 205.57$	cfs
40 min	4.78	$1.15 * 0.59 * (4.78) * 53.91 = 174.84$	cfs
50 min	4.19	$1.15 * 0.59 * (4.19) * 53.91 = 153.26$	cfs
60 min	3.75	$1.15 * 0.59 * (3.75) * 53.91 = 137.17$	cfs
70 min	3.40	$1.15 * 0.59 * (3.40) * 53.91 = 124.37$	cfs



80 min	3.12	$1.15 * 0.59 * (3.12) * 53.91 = 114.12$	cfs
90 min	2.89	$1.15 * 0.59 * (2.89) * 53.91 = 105.71$	cfs
100 min	2.70	$1.15 * 0.59 * (2.70) * 53.91 = 98.76$	cfs

- v. Step 3B – Determine the required storage volume for each storm duration:

$$V_{in} = T_d \times Q_d \times 60 \text{ seconds per minute}$$

$$V_{out} = 0.5 \times (T_d + T_c) \times Q_A \times 60 \text{ seconds per minute}$$

$$V_{req} = V_{in} - V_{out}$$

Where:

- $T_d$  = time step duration (minutes)  
 $Q_d$  = rate of discharge for the time step duration (cubic feet per second)  
 $T_c$  = time of concentration of the basin (minutes)  
 $Q_A$  = maximum allowable release rate (cubic feet per second)

For the 20 minute storm:

$$V_{in} = 20 \text{ minute} \times 260.94 \text{ cfs} \times 60 \text{ seconds per minute} = 313,128 \text{ cubic feet}$$

$$V_{out} = 0.5 \times (20 \text{ minute} + 18 \text{ minute}) \times 112.71 \text{ cfs} \times 60 \text{ seconds per minute} = 128,489 \text{ cubic feet}$$

$$V_{req} = 313,128 \text{ cubic feet} - 128,489 \text{ cubic feet} = 184,639 \text{ cubic feet} = 4.24 \text{ acre - feet}$$

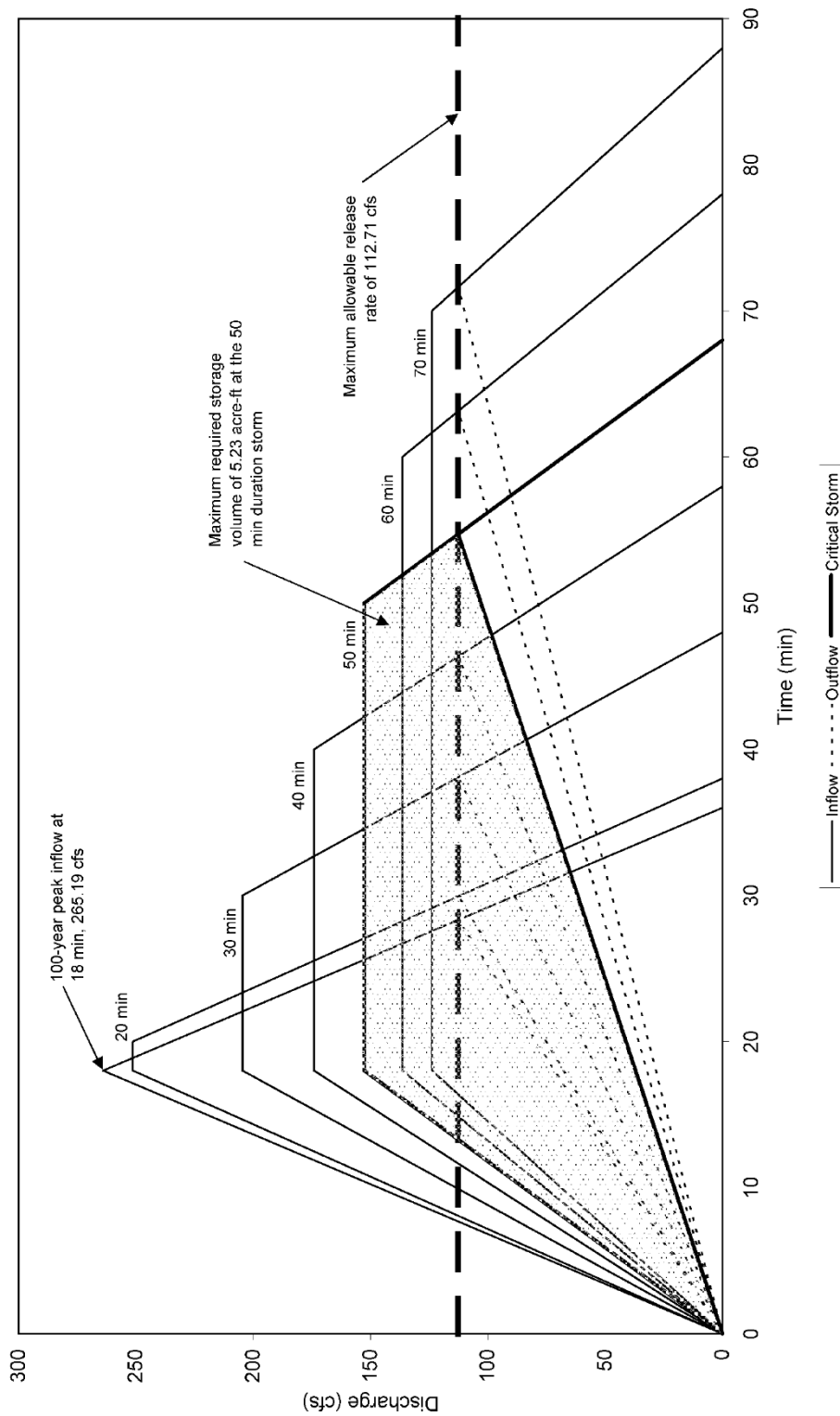
This is repeated for the other durations as shown in the example **Figure 4-15**.

- vi. Step 4 – Determine the greatest amount of storage required and at what storm duration it occurs.

Maximum volume required is 227,978 cubic feet or 5.23 acre-feet at the 50 minute storm duration, with a maximum release rate equivalent to the existing flow of 112.66 cubic feet per second.

- vii. Step 5 – Round resulting flow rates in accordance with the Stormwater Management Ordinance.

4.10.D. Detention Pond Computation Sheet – Computations performed for detention pond sizing using the Modified Rational Method as in **Section 4.10.C** shall be submitted in a format consistent with **Figure 4-14**. For detention pond computations using a hydrology modeling computer program with the Unit Hydrograph Method, relevant input and output data shall be submitted in an organized format. An electronic copy of the hydrology model shall also be submitted for review.



**Figure 4-13 – Modified Rational Method Detention Pond Design Relationship of Inflow, Outflow, and Storage Requirements**

Step	b	d	e	$T_c$ (min)	I (in/hr)	K	C	A (acre)	Q (cfs)
1									
2									

Step 3									
$T_d$ (min)	K	C	I (in/hr)	A (acre)	Q (cfs)	$V_{in}$ (cf)	$V_{out}$ (cf)	$V_{req}$ (cf)	$V_{req}$ (acre-ft)

	Step 4	Maximum $V_{req}$
		_____

Figure 4-14 – Computation Sheet for Modified Rational Method Detention Pond Design

Step	b	d	e	T <sub>c</sub> (min)	I (in/hr)	K	C	A (acre)	Q (cfs)
1	86.709	11	0.73702	26	6.06	1.15	0.30	53.91	112.66
2	86.709	11	0.73702	18	7.25	1.15	0.59	53.91	263.97

Step 3									
T <sub>d</sub> (min)	K	C	I (in/hr)	A (acre)	Q (cfs)	V <sub>in</sub> (cf)	V <sub>out</sub> (cf)	V <sub>req</sub> (cf)	V <sub>req</sub> (acre-ft)
18	1.15	0.59	7.25	53.91	263.97	285,091	121,669	163,422	3.75
20	1.15	0.59	6.90	53.91	251.31	301,574	128,429	173,145	3.97
30	1.15	0.59	5.62	53.91	204.51	368,124	162,225	205,899	4.73
40	1.15	0.59	4.78	53.91	174.13	417,901	196,022	221,879	5.09
50	1.15	0.59	4.19	53.91	152.60	457,797	229,819	227,978	5.23
60	1.15	0.59	3.75	53.91	136.45	491,206	263,616	227,590	5.22
70	1.15	0.59	3.40	53.91	123.82	520,036	297,413	222,623	5.11
80	1.15	0.59	3.12	53.91	113.64	545,462	331,210	214,251	4.92
90	1.15	0.59	2.89	53.91	105.23	568,257	365,007	203,249	4.67
100	1.15	0.59	2.70	53.91	98.16	588,956	398,804	190,152	4.37

Step 4	Maximum V <sub>req</sub>
	5.23

Figure 4-15 – Example Computation Sheet for Modified Rational Method Detention Pond Design

#### 4.11. Site Erosion Control

Refer to **Section 8** for stormwater best management practices, stormwater pollution prevention plan, and other temporary and permanent site erosion control requirements.

#### 4.12. Dam and Impoundment Design

4.12.A. Design Frequencies for Dams or Impoundments – Lakes and dams will be designed with the top of dam established by the routed design flood as defined by current TCEQ standards and regulations and shall assume fully developed watershed conditions based on the best available land use projections. All dams and impoundments shall be designed based on the TCEQ requirements regardless of whether or not they are on-channel or off-channel. The City and TCEQ design criteria for dams are dependent on size (height and storage volume) and hazard classification. The minimum size, hazard classification, design standards, and analysis methodologies shall be the current standards and regulations adopted by the TCEQ, which provides for the safe construction, operation, maintenance, repair, and removal of dams located in the State of Texas. In addition, the City has established criteria that shall also be satisfied, as outlined below and in the City of McKinney Unified Development Code. All activities that directly or indirectly impact existing or planned dams within the city limits and the extraterritorial jurisdiction of the City will be reviewed and evaluated by the Director of Engineering based on information furnished by the applicant or owner.

1. Per Texas Administrative Code (TAC) §299.1(a), dams fall under the jurisdiction of the TCEQ Dam Safety Program if they meet one or more of the following criteria, or per latest TCEQ standards:
  - a. Height greater than or equal to 25 feet and a maximum storage capacity greater than or equal to 15 acre-feet.
  - b. Height greater than or equal to 6 feet and a maximum storage capacity greater than or equal to 50 acre-feet.
  - c. High- or significant-hazard dam as defined by Texas Administrative Code (TAC) §299.14, regardless of height of maximum storage capacity.
  - d. Used as a pumped storage or terminal storage facility.
2. Hazard classification and size shall be determined based on the criteria in Title 30 of the Texas Administrative Code (TAC) §299.13 – §299.14 and the Stormwater Ordinance.
3. The Spillway Design Flood (SDF) shall be based on a percentage of the Probable Maximum Flood (PMF), specified as the minimum design flood hydrograph under the TCEQ under Title 30 of the Texas Administrative Code (TAC) §299.15(a)(1)(A). Hazard classification and size are both factors in determining the required SDF.

4. If the SDF is less than the 100-year fully developed design flood, the 100-year fully developed design flood shall be used as the design frequency.

#### 4.12.B. Additional Design Requirements

1. An engineering plan for such construction, accompanied by complete drainage design information and sealed by a licensed professional engineer, shall be approved by the Director of Engineering.
2. The spillway and emergency overflow areas shall be located so that floodwaters will not inundate any permanent habitable structures.
3. The minimum total flood storage should be based on the 100-year, 24-hour storm without auxiliary spillway operation unless the detention time of the inflow design flood exceeds 24 hours, in which case the design storm duration shall equal or exceed the detention time. The design flood shall be calculated following TCEQ criteria. Refer to **Section 4.3** for additional design rainfall criteria.
4. The design shall comply with all federal, state, and county laws pertaining to the impoundment of surface water, including the design, construction, and safety of the impounding structure. Copies of any federal, state, or county permits or approvals issued for the proposed impoundments shall be submitted to the Director of Engineering prior to commencing construction.
5. Any existing NRCS structures or other dams that are included in the project drainage area shall comply with the applicable federal, state, county, and city safety requirements for structures. Improvements may be required to upgrade the structure to the currently adopted guidelines. Refer to City of McKinney Unified Development Code, Section 804 for additional design requirements in regard to NRCS lakes.
6. Before removing, enlarging, or altering any existing lake, the applicant will furnish a study of the impacts of the alteration upon flooding conditions both upstream and downstream.
7. In order to protect lakes from accelerated sediment accumulation due to development-related upstream and adjacent grading, the Director of Engineering may require a pre-grading sediment survey of a lake with a surface area of greater than 5 acres prior to any significant grading activity in the watershed of the lake. The survey shall be conducted by the City at the developer's or contractor's expense to establish the base level of sediment in the lake. Upon completion of the project, a post-construction survey shall be conducted by the City at the developer's or contractor's expense. The developer or contractor shall be responsible for removal of additional accumulated sediment in the lake based on the difference between the pre-construction and post-construction surveys. If multiple grading projects are ongoing in the watershed of the lake, the survey costs may be shared on a pro-rata basis. The study shall be prepared by an engineer licensed in the State of Texas and submitted to the Director of Engineering for approval prior to making the proposed alteration.

8. Any improvements to existing dams or lakes or construction of new impoundments shall be made at the expense of the developer, prior to acceptance of any adjacent street, utilities, and drainage improvements, as provided for under the subdivision regulations.
9. All dams that are considered to be high hazard dams or significant hazard dams according to Title 30 of the TAC §299.14 shall have an emergency action plan submitted to the Director of Engineering for approval.
10. Auxiliary Spillway – Protection of downstream breach inundation areas and storm selection for the auxiliary spillway/top of dam will be based on the outcome of the breach analysis. The spillway design shall be based on the current standards and regulations adopted by TCEQ.
  - a. If the SDF is less than the PMF, a minimum of 2 feet of freeboard is required from the top of dam.
  - b. If the SDF is equal to the PMF, freeboard shall be design to allow enough distance below the top of dam to account for wave-run up as described in *Hydrologic and Hydraulic Guidelines for Dams in Texas* prepared by the TCEQ.

#### 4.12.C. Maintenance and Liability Criteria

1. The owner or developer shall retain their private ownership of the constructed lake, pond, lagoon, or basin and shall assume full responsibility for the protection of the general public from any health or safety hazards related to the constructed lake, pond, lagoon, or basin. The City shall have the right, but not the obligation, to enter onto the subject property to perform inspections and emergency repairs and maintenance. In the event emergency repairs or maintenance action must be taken, the responsible party shall reimburse the City its reasonable costs.
2. The owner or developer and the engineer shall assume full responsibility to ensure adequate design and construction of an impounding structure and its hydraulic discharge facilities and any associated lake, pond, lagoon, or basin. The owner or developer shall also assume full responsibility for the proper operation and maintenance of the constructed lake, pond, lagoon, basin, and any impounding structures and discharge facilities. The owner or developer shall keep the Director of Engineering advised of the currently responsible agent for operations and maintenance.

## SECTION 5 WATER AND WASTEWATER DESIGN REQUIREMENTS

### 5.1. General

#### 5.1.A. General

1. Compliance with Master Plans – All water and wastewater plans shall comply with the current edition of the Water Distribution System Master Plan (Water Master Plan) and the current edition of the Wastewater Collection System Master Plan (Wastewater Master Plan) and be submitted to the Director of Engineering for review.
2. General Design Criteria – It is the responsibility of the engineer of record (engineer) to ensure that all water and wastewater plans are in conformance with the current edition of the City’s various ordinances and master plans listed in **Section 1.3.B** and the following:
  - a. North Central Texas Council of Governments (NCTCOG) – Public Works Construction Standard Specifications and Standard Drawings
  - b. Rules and Regulations established by the Texas Commission on Environmental Quality (TCEQ)
  - c. American Water Works Association Standards (AWWA)
3. The engineer shall obtain the available record drawings (See **Section 1**), and field investigations and verifications shall be required prior to construction in accordance with the SUE Requirements in **Section 1.11**.
4. All new additions to the water system shall have two adequate points of connection to the public water system. The purpose of two connection points is to provide for continuous service for customers and fire protection when one point of connection is not in service.
5. Water and wastewater mains shall be sized and extended through the limits of a development to provide a connection for ultimate development of adjacent properties.
6. Trees shall be located minimum 8 feet from proposed utilities unless otherwise approved by the Director of Engineering.
7. Siphons shall not be allowed for new development.
8. The following information is required to be provided on all record drawings:
  - a. Nameplate photos for each butterfly valve,
  - b. Water/wastewater pipe material,
  - c. Anode bed and testing station locations,
  - d. Blow off valve and injection site locations.



9. Construction Standards and Specifications – All work and materials shall be in accordance with the current edition of the City of McKinney Construction Standards and Specifications Manual and the North Central Texas Council of Governments (NCTCOG) Public Works Construction Standards. Should a conflict be found between the two publications, the City of McKinney Construction Standards and Specifications Manual shall take precedence. In the event that an item is not covered by the City of McKinney Construction Standards and Specifications Manual, the NCTCOG Public Works Construction Standards shall apply. Notification in writing by the contractor shall be made to the engineer, City inspector, and the Director of Engineering of the issue. The Director of Engineering shall make the final decision regarding all construction materials, methods, and procedures specified in construction plans. Reference to all documents contained in the project specifications shall refer to the current edition of each document.

#### 5.1.B. Separation of Water Mains from Wastewater Mains

1. All water mains and wastewater mains shall be separated per TCEQ Rules and Regulations. Refer to the following:
  - a. Chapter 290 – Public Drinking Water SUBCHAPTER D: RULES AND REGULATIONS FOR PUBLIC WATER SYSTEMS §§290.38 – 290.47
  - b. Chapter 217 – Design Criteria for Domestic Wastewater Systems SUBCHAPTER C: CONVENTIONAL COLLECTION SYSTEMS §§217.51 – 217.71

#### 5.1.C. State Highway Alignment Criteria

1. Prior to the design of facilities within TxDOT right-of-way, the engineer shall contact the appropriate regulatory agency to determine any special design, construction requirements and/or permitting requirements and shall copy the Director of Engineering on all correspondence with each regulatory agency.
2. Water and wastewater mains within or crossing a TxDOT right-of-way shall meet the requirements of the TxDOT Collin County Area Office and the TxDOT Utility Manual. Utility permits for lines within or crossing TxDOT rights-of-way shall be processed according to **Section 1.9**.
3. No new water or wastewater mains will be allowed in the TxDOT right-of-way except for perpendicular crossings.

#### 5.1.D. Typical Utility Layouts within Right-of-Way

1. Water Mains – Water mains shall be located on the north or east parkway 4.5 feet behind back of curb. For arterial roadways, water lines shall be located outside of the ROW in a water easement. Water mains shall not be located such that valves are located underneath sidewalks or barrier free ramps.

2. Wastewater Mains – For arterial roadways, the wastewater lines shall be located outside of the ROW in a wastewater easement. For residential and collectors, wastewater mains shall be located along the roadway centerline.
3. Stormwater Mains – Stormwater mains shall be located along the centerline of the outside travel lane furthest from the water main.
4. Water and wastewater mains shall not be located within alleys unless otherwise approved by the Director of Engineering.
5. Where applicable, water and wastewater mains shall be located minimum 5 feet from power poles, measure from the outside of pipe.
6. Where Street Trees are proposed in accordance with **Section 7.4** of this manual, the utility layouts noted in that section shall be used.

#### 5.1.E. Tunneling, Jacking, and Boring

1. All water and wastewater mains to be installed under existing roadways shall be installed by a method other than open cut. Dry bores are only allowed within City right-of-way (ROW). Percussion Method (Impact Molding/Missiles) shall not be allowed within City ROW. Steel casing shall be a minimum of 1/2 inch thick and the inside diameter shall be appropriately sized for construction and maintenance of the carrier pipe. The design of the steel casing thickness shall be verified by the engineer. No bends and/or curves are permitted with casing pipes. Casings shall be required when crossing under existing and proposed arterials, highways, and railroads. Casings may also be required where deemed necessary by the Director of Engineering.
2. The construction bore and receiving pit shall be located at a minimum distance of 4 feet behind the back of curb. The engineer shall provide a distance greater than 4 feet where there is no curb or barrier protection at the edge of pavement. Additional bore setback distances or shoring shall be required to maintain roadway integrity and the safety of construction personnel. When bore and receiving pits are located on private property, permanent water and wastewater easements for the pits will be required for the installation and future maintenance of the line.
3. The engineer shall design the pipe casing for the following loading conditions and/or applicable combinations thereof:
  - a. Cooper's E-80 Railway loading or AASHTO HS20 loading, as applicable.
  - b. Earth loading with the height of fill above the casing as shown on the plans as existing or finish grade whichever is greater.
  - c. All other applicable loading conditions, including loads applied during transportation and handling.

4. The engineer shall consider the location, size, and depth of bore and receiving pits relative to existing utilities when establishing the beginning and ending stations.
5. Full panel replacement shall be required where open cut is allowed by the Director of Engineering.

#### 5.1.F. Crossings

1. Storm Drain Crossings – Where a storm drain pipe or culvert greater than 48 inches in span crosses over a water/sewer line, a steel encasement pipe shall be used to encase the carrier pipe when there is less than two foot vertical clearance.. Where the storm pipe is less than 48 inches in span, or where the storm pipe crosses underneath the water/sewer line, a concrete encasement pipe shall be used. The encasement pipe shall be extended a minimum of 10 feet from the outside edge of a box culvert or the outside diameter edge of the storm drain for future maintenance of the carrier pipe. Minimum steel encasement thickness shall be ½ inch, and minimum concrete encasement thickness shall be 6 inches.
2. Railroad Crossings – Refer to **Section 1.9** for requirements regarding coordination with regulatory agencies.
3. Pipeline Crossings – Refer to **Section 1.9** for requirements regarding coordination with regulatory agencies.
4. Creek Crossings
  - a. Water and wastewater mains constructed under any flowing stream or semi-permanent body of water, such as a marsh or pond, shall be installed inside a separate watertight steel encasement pipe. Encasement pipe shall extend 10' past the erosion hazard setback line or 100-year fully developed flood plain line, whichever is more conservative. Water mains shall have isolation valves on each side of the crossing. Wastewater mains shall have manholes on each side of the crossing. Fusible PVC or HDPE shall be used from isolation valve to valve (water) or manhole to manhole (sewer).
  - b. The engineer shall determine the type and limits of any special embedment, and specify the limits for specialized backfills to prevent soil erosion at the areas of trench backfill and as approved by the Director of Engineering.
  - c. Mains with less than 4 feet of cover shall be protected by a concrete encasement, a minimum of 10 feet past the top of the embankment on each side, and by additional streambank stabilization practices as required by the Director of Engineering. Refer to **Section 4** for additional floodplain development requirements.
  - d. Bank stabilization shall be provided for existing creek and ditch embankments disturbed by construction operations in accordance with the **Section 4** and **Section 8** of this manual and as approved by the Director of Engineering.

## 5. Aerial Creek Crossings

- a. Aerial crossings may be used when other alternatives have been evaluated and rejected. Any development within the fully developed 100-year floodplain must meet the requirements in **Sections 4** and **8** of this manual. This may include, but is not limited to, a flood study and environmental permitting. The design of aerial creek crossings shall be performed by a structural Professional Engineer licensed in the State of Texas.
- b. Aerial crossings shall meet the requirements in Section 4 of this manual related to Erosion Hazard Setback Easements (EHSE). EHSE limits shall be determined for the aerial crossing and shown on both plan and profile views. Aerial crossings shall be designed to the entire limits of the EHSE to compensate for the ultimate condition in the event the creek has eroded completely within the limits of the EHSE. Additional spans and/or piers may be needed beyond the location of the existing channel banks, which may be initially buried. Manholes shall be located 10 feet outside the EHSE.
- c. The engineer shall use a minimum 1/2 inch thick steel encasement pipe or ductile iron pipe around all aerial carrier pipes. The carrier pipe shall be restrained or welded all around joints or be a monolithic pipe between a span section. Minimum 1/2 inch thick by 6 inch wide stainless steel straps, bolts, and nuts or concrete collars shall be all around the steel encasement pipe at each pier/support structure. The steel encasement shall be extended to the manholes on each side of the crossing.
- d. A span section must withstand the hydraulic forces applied by the occurrence of a fully developed 100-year flood including buoyancy. Spans must be a minimum of 50 feet. Both the aerial crossing encasement pipe and the supporting structure shall be capable of withstanding impacts from debris and water. A scour analysis shall be performed and submitted to the Director of Engineering for review and approval.
- e. Wastewater mains shall have manholes on each side of the crossing outside of the erosion hazard setback easement. Support structures/piers shall be provided within the erosion hazard setback easement for the channel. The encasement pipe and structural piers shall extend from manhole to manhole on each side of the crossing. Pier spacing for the aerial crossing supports must maintain adequate grade and meet the requirements in **Section 4** regarding development in the floodplain.
- f. Aerial crossings that parallel an existing aerial crossing shall be provided with adequate separation (20 feet minimum) to allow for maintenance and repair operations for the crossings.

5.1.G. Easements - All proposed water or wastewater facilities that are outside of ROW or existing easements, shall be provided with permanent water or wastewater easement. The following are the minimum requirements for the easements:

1. Water and wastewater easements shall have a minimum width of 15 feet. Additional easement width shall be provided based on depth and diameter of utilities. The minimum easement width for water and wastewater mains deeper than 10 feet to the bottom of pipe, shall be equal to 2.5 times the depth of the line rounded up to the nearest 5 feet. For example, a wastewater main 13 feet deep. The wastewater easement would be  $2.5 \times 13 \text{ feet} = 32.5 \text{ feet}$ , rounded up to the nearest 5 feet = 35 feet. In addition, the minimum easement width shall increase for pipe sizes larger than 36 inch such that there is still 7.5 feet minimum beyond the outer edge of pipe, rounded up to the nearest 5 feet. (i.e. 36 inch pipe requires min 20 foot easement). Larger easement widths may be required by the Director of Engineering.
2. Single water or wastewater mains shall be located in the center of the easements. For 2 or more parallel water and wastewater mains in an easement, maintain the centerline of the utility a minimum of 7.5 feet from the edge of the easement for mains less than or equal to 10 feet deep. For mains greater than 10 feet deep, the easement width shall be 2.5 times the depth.
3. In residential developments, water and wastewater mains shall not cross residential lots. Water and wastewater easements shall be located completely on one side of a fence or property line.
4. Fire hydrants located outside of ROW or adjacent to water main easements shall be in a 15 feet wide easement along fire hydrant lead. Easement shall extend 10 feet beyond fire hydrant.
5. Two inch and smaller water meters serving multi-family residential and non-residential developments shall be in a minimum 5 feet x 5 feet water easement. Meters larger than 2 inches shall be in a minimum 15 feet x 20 feet water easement and shall not be within the ROW.
6. Temporary construction easements shall be provided to allow for construction operations for the installation.
7. Non-residential 3 inch and larger water meters shall be located in a water easement and clear of high traffic areas. The water easement shall be centered on the vault. The easement shall measure the outside dimensions of the vault and offset an additional 5 feet each side, and rounded to the nearest 5 foot interval. Water meter vaults shall be sized according to the size of the water meter. Refer to the City of McKinney Construction Standard Details for minimum water meter vault sizes.
8. Permanent water or wastewater easements are required when boring and receiving pits are located on private property. The boring and receiving pit areas are necessary for future maintenance of the line.
9. Access easements shall be provided to all water and wastewater easements including sections of water and wastewater mains that are not accessible or cutoff by tributaries, creeks or other obstructions along the permanent water or

wastewater easement. Additional access points shall be provided so that the distance between access points does not exceed 1,500 feet as measured along the maintenance access path.

10. Permanent water and wastewater easements shall have a 12 feet wide maintenance access path provided with a maximum running slope of 8H:1V and a cross slope of 10H:1V for maintenance equipment and vehicular travel. This maintenance access path shall be adjacent to any at grade utility features or appurtenances.
11. A 16 feet wide gate (locks provided by City) shall be provided at all fence locations that cross access easements and permanent easement ingress and egress locations.
12. Additional water and/or wastewater easements widths shall be provided as needed in landscape buffers or other landscape areas in accordance with the Unified Development Code to provide sufficient clearance between utilities and trees.

#### 5.1.H. Water and Wastewater Studies

1. Water studies, when deemed necessary by the Director of Engineering, will be required based on flow rates, water line distance to site, water quality issues, pressure issues, etc. for the protection of public health, safety, and welfare.
2. A sanitary sewer basin map, when deemed necessary by the Director of Engineering, will be required to ensure sufficient system capacity downstream of a proposed development.

## **5.2. Water System Design Criteria**

### **5.2.A. General**

1. The intent of the water system design requirements is to list minimum requirements for public water distribution and transmission system facilities and appurtenances.
2. Design criteria for all water systems shall comply with Texas Commission on Environmental Quality (TCEQ) current edition of Chapter 290, Subchapter D (Rules and Regulations for Public Water Systems), which is included in Part I of Title 30 of the Texas Administrative Code.
3. Water mains shall be sized and extended through the limits of a development to serve adjacent properties.
4. If a water loop serves only one property, the system shall be private and metered at each connection point to the public water system.
5. Connections to substandard mains shall not be allowed. Substandard mains shall be determined by the Director of Engineering based on criteria including, but not limited to: size, material, condition, pressure, flow rate, etc. Offsite improvements may be necessary to provide adequate water service to the site.
6. Twelve inch water lines are required along proposed or future collector roadways in accordance with the Water Master Plan.
7. Only 12 inch or larger connections are permitted on 24 inch diameter and larger transmission mains. Smaller diameter connections less than 12 inch diameter shall be made on internal or parallel development lines.
8. If allowed by the Director of Engineering to connect to the water system outside of the property's respective pressure plane, the minimum static pressure shall be 50 psi. A temporary booster system or pressure reducing valve may be required.

### **5.2.B. Water Services**

1. All water services from the main to the meter shall be a 1-inch minimum size. All water services from the main to the structure shall be size on size including the meter size, except that standard service line sizes from the main to the meter shall be 1-inch, 2-inch, or 4-inch. All water services shall be located along the lot lines or adjacent property lines. Water services and meters shall be sized in accordance with Appendix E of the International Plumbing Code. Water services shall be connected to the nearest available water main.
2. All water services shall be individually tapped to the water main. Bullhead connections may be utilized as approved by the Director of Engineering.
3. A domestic service connection shall not be allowed on fire hydrant leads.



4. Service saddle shall be double bronze flattened straps (no banded straps shall be allowed) with brass body or stainless steel double bolt wide straps with stainless steel body. Minimum size tap shall be 1 inch diameter using a stainless steel single strap with a minimum 2 inch band width. Tap locations, for taps 2 inches or greater, need to be a minimum of 5 feet from end of pipe section or other pipe connection.
5. Detector pads embedded in sand shall be installed above all service connections.
6. Each meter box shall be located adjacent to the curb and installed after street pavement has been completed and curbs backfilled. Bullhead meter boxes shall be spaced 2 feet apart centered. A 2 inch minimum meter locator plate shall be placed in the recess of the meter boxes. In residential developments, bullhead water services (two meter boxes with single water service line tap) are required in single family residential developments.
7. All meters supplied by the City will be at contractor's expense. Concrete meter vaults are required for meter sizes 3 inches and larger and shall be provided by the contractor.
8. In single family residential developments, the nearest edge of the water meter box shall be a minimum of 6 inches behind the back of curb, and the water service shall be no more than 12 inches deep, covered with a meter box in place at grade. If no curb is present, the water service shall be located at the property line, no more than 12 inches deep, covered with a meter box in place at grade. Along roadways without a curb, the water service line shall be constructed at a minimum of 18 inches below the ditch flowline.
9. Commercial water meters will be located in a water easement and clear of high traffic areas. Water meter vaults shall be sized according to the size of the water meter and to allow for a minimum of a 12 inch clear working area for maintenance and operation. Minimum water meter vault sizes are shown in the City of McKinney Construction Standard Details.
10. Installation of commercial meters will include two mainline valves, one bypass valve with chain and lock, a strainer, and bypass line, all located inside the vault. Clearances between fasteners on valves, strainers, and meters to interior surfaces shall provide adequate room for maintenance.
11. Water meter boxes shall be provided for each service per City Specifications. Requests for meters larger than those indicated above should be submitted with an installation detail specifying dimensions, materials and location of the water meter vault for review and approval by the Director of Engineering.

#### 5.2.C. Water Demand and Supply

1. Residential development submittals shall include the total number of units and the total acres of the proposed development. Non-residential development submittals shall include estimated water use records showing the minimum hourly demand, maximum hourly demand, maximum daily demand, total building square footage,



and the total acres for the proposed development. The projected maximum daily demand and maximum hourly demand shall be calculated and shown in MGD in accordance with the current edition of the Water Master Plan. A water basin map and sizing analysis shall be provided for water mains that serve more than 300 single family units, 400 multi-family units, or an equivalent combination of those uses or other uses.

2. The North Texas Municipal Water District (NTMWD) supplies treated water at the Gerrish Pump Station, McKinney Ranch Pump Station, University Pump Station, and Redbud Pump Station as shown in the Water Master Plan.

#### 5.2.D. Pressure Planes

1. The City currently operates three pressure planes, the 794 Service Area, the 850 Service Area, and the 920 Service Area. A proposed fourth pressure plane, the 840 Service Area, was established. It is envisioned that the proposed 840 Service Area will be supplied by the 794 Service Area and pressurized with a booster pump station and pneumatic tank. The 794 Service Area has a pressure range from 40 psi to 120 psi, the 850 Service Area has a pressure range from 55 psi to 125 psi, the 920 Service Area has a pressure range from 50 psi to 140 psi, and the 840 Service Area has a pressure range from 65 psi to 90 psi. Higher pressures are experienced in the lower ground elevations in each service area in locations in close proximity to Wilson Creek or the East Fork of the Trinity River and their tributaries. The locations of the existing and proposed pressure planes are shown in the Water Master Plan.
2. The service area elevation designation is related to the high water level of elevated storage tanks.
3. Prior to the design of a water system, the engineer shall investigate and determine if the proposed water main crosses the boundary between any of the pressure planes. For those pressure planes separated by a street, a main shall be provided for each pressure plane on their respective side of the street. Proposed mains that approach pressure zone boundaries shall be designed to loop within their designated pressure planes as shown in the Water Master Plan.

#### 5.2.E. Sizing Water Distribution Mains

1. General
  - a. Water mains shall be sized to have maximum velocities of 8 feet per second for Maximum Daily Demands and maximum velocities of 10 feet per second for Combined Maximum Daily Demand and Fire Flow Demands.
  - b. **Table 5-1** provides the water demand for residential land uses and shall apply for any residential development where the lot layout has not been finalized.
  - c. **Table 5-2** provides the water demand for non-residential land uses.

**Table 5-1 – Residential Water Demand by Land Use**

District	Land Use	Estimated Units Per Acre	Population Per Unit	Maximum Daily Demand (gpad)	Maximum Hourly Demand (gpad)
R43	Estate	1.0	3.2	1,120	2,240
R12	Single Family	2.7	3.2	3,024	6,048
R8	Single Family	4.1	3.2	4,592	9,184
R6	Single Family	5.4	3.2	6,048	12,096
R5	Single Family	6.5	3.2	7,280	14,560
TR1.8	Townhome	18.1	2.0	12,670	25,340
FR	Flex Residential	9.0	2.5	7,875	15,750
MR	Mixed Residential	18.0	2.0	12,600	25,200
MF30	Multi-Family	22.5	2.0	15,750	31,500
MHR	Mobile Home Park	8.0	2.0	5,600	11,200

**Table 5-2 – Non-Residential Water Demand by Land Use**

Land Use	Max. Daily Demand	Max. Hourly Demand
Town Center Redevelopment	3,500 gpad	4,000 gpad
Town Center Downtown	3,000 gpad	3,000 gpad
Ex. Retail/Office, Fut. Town Center Mix, Neighborhood Comm, Prof. Campus / Employ. Mix, Entertain Ctr & Mixed Use Center, Restaurant	1,500 gpad	2,700 gpad
Institutional – Schools, Hospitals, Nursing, Government, etc.	1,500 gpad	2,000 gpad
Future Manufacturing & Warehousing / Employ Mix Comm. Center, Comm Center,	2,000 gpad	3,000 gpad
Exist. Industrial & Future Manufacturing & Warehousing	2,500 gpad	3,000 gpad

Entertainment Center	3,000 gpad	3,900 gpad
Professional Campus	3,000 gpad	4,500 gpad
Professional Campus / Comm. Center	6,000 gpad	6,000 gpad
Exist. Open, Amenity Zone & Parks	1,500 gpad	1,500 gpad
Town Center Mix	1,500 gpad	2,700 gpad
Urban Living	1,500 gpad	2,700 gpad
Utilities & Airport	1,000 gpad	1,000 gpad

*gpad –gallons per acre per day*

*Source: 2019 Water Distribution System Master Plan Update*

- d. Land uses not listed shall be classified by the land use they most nearly resemble in **Table 5-2** or calculated by the engineer in accordance with the anticipated use. The engineer shall submit the Maximum Daily Demand and the Maximum Hourly Demand to the Director of Engineering for review and approval.
- e. The engineer shall contact the Director of Engineering to obtain the map of existing pressure ranges for the project area during maximum daily demands and/or determine the size of water main required from the current edition of the Water Master Plan. For all developments, re-developments, and any type of facility tying into the City's water distribution system, the following guidelines shall be used:
  - i. The engineer shall obtain the available record drawings (See **Section 1**). When record drawings are not available, field investigations and verifications shall be required prior to construction.
  - ii. The standard water main sizes that shall be used are noted in the **Table 5-3**.
  - iii. Fire flows for all districts shall be calculated with a minimum residual pressure of 20 psi under combined fire and domestic (Maximum Daily Demand) water flow conditions and/or the latest requirement by the TCEQ. Fire flows shall be as determined by Appendix B of the International Fire Code as amended by the City of McKinney. For single-family residential areas, a minimum fire flow of 1,500 gpm shall be provided. For multi-family, commercial, and industrial areas, a minimum fire flow of 3,500 gpm shall be provided. Buildings larger than 75,000 square feet may require greater fire flows per the Fire Department.
  - iv. Mains are to be sized to ensure less than 1 foot of head loss per 1000 feet of water main using a Hazen Williams coefficient of  $C = 110$  for the

Maximum Hourly Demand flow rates within the subdivision internal distribution system.

- v. Mains shall be sized to provide service to adjacent properties.

**Table 5-3 – Standard Water Main Sizes**

8 inch	12 inch	16 inch	18 inch
20 inch	24 inch	30 inch	36 inch
42 inch	48 inch	54 inch	60 inch
66 inch	72 inch	----	----

2. Single Family Residential – 12 inch mains shall be required along all collector streets and other areas as determined by the Director of Engineering. Eight inch mains are required along smaller residential streets.
3. Multi-Family Residential – Minimum size main in any multi-family project shall be 8 inches. Mains over 600 feet in length between intersecting mains or mains supplying more than one fire hydrant/fire service line shall be 12 inch diameter unless an 8 inch diameter size has been verified by the City’s modeling consultant. The City’s consultant will provide the results of the modeling efforts within a brief letter report. The scope for the modeling efforts will be reviewed by the developer and the Director of Engineering for approval prior to performing the modeling efforts. The expense of the modeling efforts and letter report is the responsibility of the developer.
4. Non-Residential – Mains over 1,000 feet in length between intersecting mains or mains supplying more than two fire hydrants/fire service lines shall be 12 inch diameter unless an 8 inch diameter size has been verified by the City’s modeling consultant. The City’s consultant will provide the results of the modeling efforts within a brief letter report. The scope for the modeling efforts will be reviewed by the developer and the Director of Engineering for approval prior to performing the modeling efforts. The expense of the modeling efforts and letter report is the responsibility of the developer.

#### 5.2.F. Horizontal Alignment and Vertical Alignment

1. The following guidelines shall be used for the placement of water mains:
  - a. Sixteen inch and larger water mains shall be designed in straight alignments if possible. Avoid excessive number of high points and low points between cross street connections.
  - b. Minimum radius of curve and maximum deflection angle of pipe joints will be restricted to 75 percent of manufacturer’s recommendation, after which the use of horizontal or vertical bends will be required.

- c. Restrained joints and concrete thrust blocks shall be provided for each dead end, valve, bend, tee-connection, fire hydrant, reducer, and where changes in pipe diameters or directions occur. The size and shape of concrete thrust blocks shall be specified by the Engineer. The length of restrained-joint piping and details of joint-restraint glands, clamps, friction slabs, or other anchors shall be specified by the Engineer. Restraining mechanisms for PVC pipe and fittings shall be tested and shall meet the requirements of ASTM F1674.
- d. All bends shall be 45 degrees or less where practical. Two 45 degree bends in a series shall be separated by a distance of five pipe diameters instead of a 90 degree bend.

5.2.G. Depth of Cover

- 1. The minimum depth of cover for water mains are indicated in **Table 5-4**.

**Table 5-4 – Depth of Cover to Top of Pipe**

Pipe Size	Minimum Depth of Cover
6 inch through 8 inch	4.0 feet
12 inch through 18 inch	5.0 feet
20 inch and larger	6.0 feet

- 2. The engineer shall consider the ultimate roadway elevations in determining the depth of cover. Additional depth of cover shall be required for future development and as directed by the Director of Engineering. Depths of cover greater than 8 feet shall be approved by the Director of Engineering.

5.2.H. Pipe Material

- 1. The specification of pipe material is the responsibility of the engineer based on the analysis of specific site, soil conditions, loading conditions, and pressure requirements. The guidelines in Table 5-5 are based on pipe size only and in no way relieve the engineer of the responsibility of pipe material specifications applicable to the particular project and restrictions due to special construction methods.
- 2. Additional specifications for the pipes referenced in **Table 5-5** are as follows:
  - a. Corrosion Protection System
    - i. All Bar Wrapped Concrete Cylinder, Ductile Iron, and Steel Pipe will require a Corrosion Protection System (CPS). The CPS must be designed by a NACE certified Professional Engineer with considerable experience in corrosion engineering.

- ii. A detailed corrosion survey shall be conducted along the alignment to identify potential corrosion problems and recommend a corrosion protection system.
  - iii. Based on the corrosion survey, a CPS shall be designed to include a Galvanic Protection System. The CPS shall be submitted for review and approval by the Director of Engineering.
  - iv. Dissimilar metals shall be isolated using insulating kits or other means to prevent galvanic corrosion.
- b. Steel Pipe
- i. Design fittings, special, associated joints and all field and shop welds shall have load capacities equal to or greater than those of connecting pipe segments.
  - ii. Design bulkhead, closure, or test plug, as needed for closure of sections and for field hydrostatic testing.
  - iii. Design and locate weld lead outlets as needed.
  - iv. Design and locate flush and sampling ports, as needed, for hydrostatic testing and disinfection.
- c. PVC Pipe
- i. PVC pipes shall be marked on the spigot ends with dual insert marks. The first mark, if visible, means the pipe needs to be inserted more. The second mark always needs to be visible .
  - ii. If the second mark is not visible, then the pipe was over-inserted and the joint needs to be disassembled and correctly installed
- d. HDPE Pipe
- i. Formulated with carbon black and/or ultraviolet stabilizer.
  - ii. HDPE pipe size selection needs to account for the pipe wall thicknesses to meet the internal diameters listed within **Table 5-5**, internal pressures, and depth of bury.

**Table 5-5 – Pipe Materials for Mains**

<b>Internal Diameter Pipe Size</b>	<b>Pipe Material</b>
4 inch through 12 inch	<ul style="list-style-type: none"> <li>• Blue PVC, AWWA C900, minimum DR 18 (DR 14 for fire service lines).</li> <li>• Ductile Iron, AWWA C151, working pressure of 150 psi with 100 psi surge pressure, cement mortar lined, polyethylene encased.</li> <li>• Blue stripe HDPE, AWWA C901/C906, DIPS minimum DR 11, ASTM D2239, ASTM D2737, ASTM D3035, ASTM F714 and ANSI/NSF 14/61 listed.</li> <li>• PVC, AWWA Fusible C900, minimum DR 18 (DR 14 for fire service lines).</li> </ul>
16 inch through 20 inch	<ul style="list-style-type: none"> <li>• Ductile Iron, AWWA C151, working pressure of 150 psi with 100 psi surge pressure, cement mortar lined, polyethylene encased.</li> <li>• Bar Wrapped Concrete Steel Cylinder, AWWA C303, working pressure of 150 psi with 100 psi surge pressure.</li> <li>• Blue stripe HDPE, AWWA C901/C906, DIPS minimum DR 9, ASTM D2239, ASTM D2737, ASTM D3035, ASTM F714 and ANSI/NSF 14/61 listed, working pressure of 150 psi with 100 psi surge pressure.</li> <li>• Blue PVC, AWWA C900, minimum DR 18.</li> <li>• Blue PVC, AWWA Fusible C900, minimum DR 18 (DR 14 for fire service lines).</li> </ul>
24 inch	<ul style="list-style-type: none"> <li>• Ductile Iron, AWWA C151, working pressure of 150 psi with 100 psi surge pressure, cement mortar lined, polyethylene encased.</li> <li>• Bar Wrapped Concrete Steel Cylinder, AWWA C303, working pressure of 150 psi with 100 psi surge pressure, reinforced concrete cylinder pipe.</li> <li>• Steel, AWWA C200 and C205, working pressure of 150 psi with 100 psi surge pressure, cement mortar lined, polyurethane coating applied to the exterior, polyurethane coating shall utilize plural component polyurethane products.</li> <li>• Blue PVC, AWWA C900, minimum DR 18. HDPE, AWWA C901/C906, DIPS minimum DR 9, ASTM D2239, ASTM D2737, ASTM D3035, ASTM F714 and ANSI/NSF 14/61 listed, working pressure of 150 psi with 100 psi surge pressure.</li> <li>• PVC, AWWA Fusible C900, minimum DR 18.</li> </ul>
30 inch and larger	<ul style="list-style-type: none"> <li>• Ductile Iron, AWWA C151, working pressure of 150 psi with 100 psi surge pressure, cement mortar lined, polyethylene encased.</li> <li>• Bar Wrapped Concrete Steel Cylinder, AWWA C303, working pressure of 150 psi with 100 psi surge pressure, reinforced concrete cylinder pipe.</li> <li>• Steel, AWWA C200 and C205, working pressure of 150 psi with 100 psi surge pressure, cement mortar lined, polyurethane coating applied to the exterior, polyurethane coating shall utilize plural component polyurethane products.</li> </ul>

#### 5.2.I. Fittings

1. All valves and fittings shall be restrained per the Utilities Approved Materials List in the Construction Standards and Specifications Manual.
2. Fittings shall be ductile iron in accordance with AWWA C110 or AWWA C153. All buried metal shall be wrapped in polyethylene tube wrap.

#### 5.2.J. Pipe Embedment

1. The type of embedment for water mains less than 16 inch diameter shall be NCTCOG Class "H" embedment extended to 12 inches minimum over the top of pipe.
2. For pipe sizes 16 inches and greater, the embedment class shall be a function of the pipe material selected including dead and live load considerations provided by the engineer. The engineer shall submit calculations on the embedment selected for the particular pipe type.
3. Trench dams may be required by the Director of Engineering depending on the ground water potential, pipe slope and length of sloped line segments.

#### 5.2.K. Dead-End Mains

1. Dead-end mains are not allowed unless approved by the Director of Engineering. The design of all water distribution systems should include the opportunity for future looping or interconnect of any approved or proposed dead-end line.
2. All dead-end lines shall only be installed upon approval from the Director of Engineering and at a maximum length of 150 feet.
3. Residential cul-de-sac dead end lines shall be reduced down to 4 inch diameter from the beginning of the cul-de-sac bulb to the last household water service connection. The fire hydrant lead shall be installed prior to the reduction of the main line size.
4. Where dead-end mains are approved, the engineer shall provide an automatic flush valve at the end of the dead-end main. The discharge from the automatic flush valve shall be routed underground to connect to the storm sewer system. Water quality concerns shall be the primary consideration when evaluating whether dead-end mains will be approved.

#### 5.2.L. Fire Hydrants

1. Fire Department Connections and Fire Sprinkler Systems
  - a. At least one fire hydrant shall be within 50 feet of any Fire Department Connection (FDC). The FDC shall face and front a fire lane. FDC's shall be located in accordance with the International Fire Code as amended by the City of McKinney. Stand-alone FDCs located adjacent to parking lots shall be properly protected.



- b. Fire lines exceeding 100 feet in length from the riser room to the circulating water main shall install a backflow preventer in a vault adjacent to the public water easement. The Fire Marshal shall approve the construction plans for the vault, fittings, valves, and double detector check and shall issue a separate permit for fire sprinkler systems.

## 2. Fire Hydrant Spacing

- a. Single Family Residential – Fire hydrants shall be located at all intersecting streets and at intermediate locations between intersections as necessary to provide a maximum spacing of 500 feet between fire hydrants as measured along the route. The route shall be clear of permanent barriers and adjacent private property.
- b. Multi-Family Residential
  - i. Fire hydrants shall be located at all intersecting streets and at intermediate locations between intersections as necessary to provide a maximum spacing of 300 feet as measured along the length of the centerline of the fire lane or roadway. Any structure at grade shall be no further than 500 feet from at least two fire hydrants as measured along the route. The route shall be clear of permanent barriers and adjacent private property.
  - ii. At least one fire hydrant shall be within 50 feet of any Fire Department Connection as described in **Section 5.2.L**.
  - iii. Fire hydrants shall be at least 35 feet from all buildings.
- c. Non-Residential
  - i. Non-Residential Property – As the property is developed, fire hydrants shall be located at all intersecting streets and at intermediate locations between intersections as necessary to provide a maximum spacing of 300 feet as measured along the length of the centerline of the fire lane or roadway. The front of any building at grade shall be no further than 300 feet from a minimum of two fire hydrants as measured along the route. The route shall be clear of permanent barriers and adjacent private property.
  - ii. Fire Sprinkler System Stub-out – The Fire Marshal shall approve the vault, fittings, valves, and double detector check and will issue a separate permit for fire suppression systems.
  - iii. Fire hydrant spacing shall be in accordance with Appendix C of the current edition of the International Fire Code.
  - iv. At least one fire hydrant shall be within 50 feet of any Fire Department Connection as described in **Section 5.2.L**.
  - v. Location of fire hydrants shall be installed outside of the PCs and PTs of curve radii of fire lanes (no fire hydrants shall be located within the radius

delta angle between the PC and PT of the curve). Fire hydrants shall be at least 35 feet from all buildings.

- vi. Where access could be blocked due to a barrier between the fire hydrant and the building which it is intended to serve, additional fire hydrants shall be provided to improve the fire protection.
- d. Spacing along Arterials – Where new water mains are extended along streets where hydrants are not needed for protection of structures or similar fire problems, fire hydrants shall be provided at spacing not to exceed 1,000 feet to provide for transportation hazards. For divided roadways, fire hydrants shall be provided at a spacing not to exceed 1,000 feet for each side of the roadway with a 500 feet spacing on an alternating basis between the fire hydrants.

### 3. Fire Hydrant Installation

- a. Fire hydrants shall be located a minimum of 3 feet and a maximum of 6 feet from the fire lane or roadway as measured from the centerline of the fire hydrant to back of curb, edge of pavement, or fire lane.
- b. A 3 feet clear radius shall be maintained for access and operation of the fire hydrant.
- c. Fire hydrants placed on private property shall be located in water easements and adequately protected behind a curb or curb stop, pipe bollards, or other methods as approved by the Director of Engineering and the Fire Department. Curb or curb stop, pipe bollards, or other methods shall be the responsibility of the owner.
- d. Fire hydrants located on public or private property shall be accessible to the Fire Department at all times.
- e. Fire Hydrants are not permitted in the bulb of a cul-de-sac due to limited parking area and reduced water main size if a dead-end line.
- f. Standard fire hydrant barrel shoe depth where ever practical shall be 5 feet. The fire hydrant lead line shall be adjusted to meet the standard fire hydrant depth.

### 4. Fire Hydrant Leads

- a. Fire hydrant leads shall be a minimum of 6 inches and have a bury depth of 4 feet.
- b. Valves shall be placed on all fire hydrant leads. The connection to the main line shall include a flanged tee connected to a flange by mechanical joint gate valve. The mechanical joint shall be restrained so that the valve is anchored to the main.

- c. Eight inch mains shall be connected so as to serve not more than two fire hydrants located between intersecting mains. Every development shall provide adequate water capacity for fire protection purposes. The procedure for determining fire flow requirements for building or portions of buildings shall be in accordance with the current City adopted International Fire Code. The minimum required fire flow shall be 1,500 gpm at 20 psi.
  - d. Fire hydrant leads shall not exceed 50 feet unless approved by the Director of Engineering. If a variance is granted to exceed 50 feet, fire hydrant leads exceeding 100 feet in length from the circulating water main shall install a backflow preventer in a vault adjacent to the public water easement.
  - e. Existing 4 inch mains used for hydrant supply shall be replaced and dead-ends eliminated where practical. Existing 6 inch lines shall be connected so that not more than one fire hydrant shall be between intersecting lines. New fire hydrants shall not be connected to substandard mains.
  - f. For main replacement projects in established neighborhoods, fire hydrants should be designed as close as possible to the old fire hydrant location, provided coverage is adequate. Fire hydrants shall not be installed closer than 9 feet to any wastewater main or any wastewater appurtenance.
5. Specifications – Fire hydrants shall be three-way breakaway type no less than 5-1/4 inch size. Mechanical joint connection is required.
  6. Public and Private Fire Mains – Public and private fire protection water mains shall be installed according to the NCTCOG, National Fire Protection Association (NFPA) 24 and the current City adopted International Fire Code.

#### 5.2.M. Valves

1. General – The following guidelines should aid the engineer in placement of valves on proposed water mains.
  - a. Valves are to be located at street intersections at or near side property lines, unless a specific construction issue requires the placement of the valve at a nonstandard point of connection. Valves shall be installed on each branch and mainline segment at tees and crosses for 12 inch or larger water mains. Site specific approval may be given to use a fire hydrant isolation valve within 100 linear feet of the connection point.
  - b. Valves 20 inches and under shall be Resilient Wedge Gate Valves (RWGV). Valves shall be spaced 600 feet or less in a single family residential district and 500 feet or less in all other districts. Valves shall be placed in such a manner as to require two, but not more than three valves, to shut down each main segment without shutting off more than one fire hydrant.
  - c. Twenty four inch and larger valves shall be butterfly type and shall be spaced at a maximum of 1,000 foot intervals. Butterfly valves shall be located in a

vault per the City of McKinney Construction Standard Details. All valves shall have horizontal mounted actuators with a manhole for access to the actuators.

- d. Valves shall be placed at or near the ends of mains in such a manner that a shut down can be made for a future main extension without causing loss of service on the existing main. A minimum of 20 feet of main shall be installed past the valve and mechanical pipe thrust restraints shall be used to anchor it.
  - e. Main line water valves shall be provided on each side of the domestic service line connection serving Care Facilities, Emergency Rooms, Hospitals, Clinics, Schools, Montessori Schools, and Day Cares.
  - f. Where fire lines are connected to the water main, valves shall be installed on one side of the connection to provide the ability to isolate the main line and continue to provide water to the fire line. The fire line shall be provided with a valve at the connection with the main line.
  - g. Valve boxes shall be provided for buried valves. They shall be three-piece screw-type cast iron boxes of the extension type. The three pieces shall consist of the top section, bottom section, and cover.
  - h. Two inch square nuts that would be over 5 feet deep shall have valve stem extensions. In these cases, the 2 inch square valve operating nut shall be no greater than 2 feet from the finish grade. Valve box extensions may be cast iron or C-900 PVC.
  - i. Mechanical joint restraints are required for all valves.
  - j. The location of isolation valves shall be placed to anticipate system flushing and disinfection.
  - k. All valves shall be located outside of barrier free ramps.
  - l. All valves shall be stationed along water mains including profiles and reference roadway centerline stationing.
2. Air Release, Air/Vacuum, and Combination Air Valves
- a. Air release valves, air/vacuum, and combination air valves shall be required on 16 inch and larger water mains and as necessary for proper system operation. There are three primary functions of the valves that the engineer shall consider as follows:
    - i. To vent large volumes of air during filling of the line;
    - ii. To allow air into the pipe during emptying for maintenance and/or repairs; and,
    - iii. To vent small volumes of air that come out of solution during service.

- b. Typically these are installed at high points where the pipeline has a vertical change in gradient. Additional installation locations may be requested by the Director of Engineering.
- c. A fire hydrant shall be required at high points on 12 inch water mains for air relief and flushing maintenance operations. When a fire hydrant cannot be used, an air release valve may be approved by the Director of Engineering.

### 3. Flush Valves

A corporation stop shall be a 2 inch minimum ball type with compression inlet fitting with tee head shut off and a compression outlet fitting, designed for a minimum working pressure of 300 psi. The 2 inch curb stop shall be ball type with compression inlet fitting. Pipe shall be 2 inch diameter, DR-9 (250 psi) HDPE poly pipe with PE4710 as specified in ASTM F714.

## 5.2.N. Connections to Existing Water Mains

### 1. Tapping Sleeves and Valves

- a. Size on size tapping sleeves are not allowed. The largest allowable tapping sleeve shall be the main line size less one standard pipe size (Example: 16 inch x 12 inch, 8 inch x 6 inch, etc.). If a size on size connection is required, then a cut-in connection shall be used.
- b. Connections to an existing line shall be made with full body stainless steel tapping sleeve and valve. A resilient wedge gate valve shall be flanged to the tapping sleeve.
- c. The tap location needs to be a minimum of 5 feet from an existing bell and spigot connection or other type of pipe connection.

- 2. Cut-In Connection – When connecting to an existing main, it may be required to provide a cut-in connection with a tee and valve being installed into the existing main in lieu of a tapping sleeve and valve where there is not an existing main line valve between proposed water connection locations as directed by the Director of Engineering. A test shut down of the existing water main(s) shall be conducted by the Public Works Department. The requirement for a test shut-down may be waived with approvals of the Director of Engineering and the Water Superintendent.

- 3. Four-Way Connections – The installation of a cross fitting shall not be allowed. Four-way connections shall be made via offset tees or a ring connection. Valves shall be provided on all legs of offset tees and ring connections except that a single valve may be placed between the offset tees or within the ring segment. Through legs of tees shall be equal to the largest pipe size. The ring segment shall be equal to or greater than the smaller pipe size. Where pipe size changes occur at a four-way connection, the largest size on each leg shall govern.

4. Blow-off valves shall be required at low points on mains 16 inches or greater in accordance with the City of McKinney Construction Standard Details.
5. Requirements for Abandoning Water Mains
  - a. The engineer is to note the limits and appropriate conditions for abandoning existing water mains that are being replaced.
  - b. The engineer shall make allowances to permit the existing and proposed mains to remain in service simultaneously thereby providing a means for transferring customer's services from the old main to the new main with minimum interruption. If the construction of a proposed main necessitates the abandoning of the existing main prior to the new main's placement into service, then provisions for a temporary water main with services must be addressed with the design.
  - c. Abandoned lines to remain in place shall have the interior completely filled with grout. Valves to be abandoned in place shall have any extensions and the valve box removed and shall be capped in concrete.
  - d. Existing fire hydrants and valves located on mains being abandoned are to be removed and delivered to the Public Works Department.
6. Replacement Lines – To replace an existing line, the new line should be designed parallel to the line being replaced. The engineer shall perform a field investigation to determine pavement condition over the existing main. Based on this field investigation, the engineer shall include additional quantities for pavement replacement, if needed. Also, locate the proposed main at least 5 feet away from the existing curb to avoid damaging the curb or undercutting the pavement during installation of the proposed line. On lines being abandoned, the engineer should note and locate points of cut and plug at the junction with the line that remains in service.

#### 5.2.O. Abandonment of Water Mains

1. The engineer shall specify on the plans the limits and appropriate conditions for abandoning existing water mains that are to be replaced.
2. The engineer shall ensure that the service lines tying into the existing water line to be abandoned are transferred to the new main so a live water main is not abandoned. The engineer shall make allowances to permit the existing and proposed mains to remain in service simultaneously thereby providing a means for transferring customer's services from the old main to the new main with minimum interruption. If the construction of a proposed main necessitates the abandoning of the existing main prior to the new main's placement into service, then provisions for a temporary water main with services must be addressed with the design.

3. Abandonment of water mains shall be in accordance with the City of McKinney Construction Standard Details. All abandoned water main lines shall be cut and plugged and all void spaces within the abandoned line shall be filled with grout. Valves to be abandoned in place shall have any extensions and the valve box removed and shall be capped in concrete.
4. Existing fire hydrants and valves located on mains being abandoned are to be removed and delivered to the Public Works Department. Public Works shall accept materials at their own discretion.
5. Existing valve stacks and unused water meters located on mains being abandoned are to be removed.
6. Mains being abandoned within 50 feet of the corner clip right-of-way of existing or future intersections are to be removed rather than abandoned in place.
7. Abandonment of all utilities within TxDOT ROW shall comply with TxDOT standards.

#### 5.2.P. Flushing and Disinfection

1. The following information pertains to the current Engineering Department Pre-Construction Agenda.
2. General
  - a. All flushing and disinfection shall comply with AWWA C-651.
  - b. All work shall be coordinated in advance (minimum 72 hours) with the designated construction inspector.
  - c. The contractor is responsible for the cost of all water used in the filling, flushing, and disinfection of the new potable water system.
  - d. The contractor shall submit a Flushing and Disinfection Plan for review prior to beginning any water main installation. This plan shall show all the information needed to commission the public water mains and appurtenances in accordance with all applicable requirements. The Flushing and Disinfection Plan shall indicate how the contractor will ensure appropriate minimum velocities and flows to ensure proper flushing. Special attention should be paid to the larger diameter, long water mains. Alternative methods as identified in AWWA 651 may be more appropriate.
  - e. Sample points shall be provided on each 1,000 feet intervals of new water main, at the end of line, and at each branch on the main line.
3. Initial Fill – The contractor shall utilize a jumper connection with backflow preventer and temporary meter assembly connected to an existing fire hydrant to fill the new system.



4. Debris Flush (Segment Flush)

- a. Segmented Debris Flush – The new water distribution system shall be flushed one segment at a time, using the in-line isolation valves and fire hydrants to ensure a full flow through each hydrant. The contractor shall provide all assistance necessary to operate valves and hydrants under the direction of the construction inspector.
- b. The contractor may utilize the jumper or the main isolation valve to perform the debris flush. When the jumper is used, the contractor may perform all necessary activities as described below without requesting the assistance of the Public Works Department.
- c. When the main isolation valve is used, the construction inspector must be given 72 hour notice to coordinate with the Public Works Department valve crew. The Public Works Department valve operator is the only one on-site authorized to operate the isolation valve on the “live” City system.
- d. When using the jumper system to complete the debris flush, the contractor shall ensure there is an adequate supply to maintain appropriate flush velocities and flows.
- e. When the main isolation valve is used to complete the debris flush, the Public Works Department valve operator will utilize the main in-line valve as long as the new valves and fire hydrants are open to prevent backflow into the water system.
- f. When using this method, the City valve operator will use a flow rate meter to estimate the amount of water used. The Public Works Department will report these readings to the billing office. The contractor is responsible for the cost of the water used.

5. Disinfection

- a. The contractor shall provide the equipment and material needed for the disinfection process. Chlorine shall be loaded into all portions of the new water distribution system. The water source for the loading and pushing of chlorine shall be from a hose with a double check valve assembly (jumper connection) connected to a fire hydrant. Main line water valves shall not be used for loading and pushing of chlorine. Chlorination to include the main lines, fire hydrant leads, and all water services.
- b. The construction inspector will verify the chlorine residual at the beginning of the process (minimum 100 mg/L).

6. Disinfection Flush

- a. After a minimum of 24 hours, the construction inspector will verify a minimum chlorine residual of 10 mg/L.



- b. The contractor shall flush the new distribution system and appurtenances to reduce the residual to a maximum of 4 mg/L. This includes all fire hydrants and water services. The contract may utilize the jumper system or the main isolation valve to perform this flush. Any operation of the main isolation valve will require coordination with the Public Works Department valve operator. The contractor is responsible for the cost of all water used. Once the residual has been dissipated and the water has remained in the pipe for a minimum of 16 hours with no use or flushing during the minimum of 16 hours, then the system is ready for the bacteriological testing. Refer to the City of McKinney Construction Standard Details for temporary water test station information.
  - c. All flush water (potable water and super chlorinated water) shall be diverted to the nearest wastewater manhole by hose including all fittings and appurtenances. A strainer shall be used on the hose discharge into the wastewater manhole. Maintain a minimum 1 foot vertical air gap between end of discharge hose and manhole frame. If a sanitary sewer manhole is not available then the contractor shall provide a dechlorination diffuser at the flush outlet point(s) including all fittings and appurtenances. Detention may be allowed on-site dependent on weather conditions and approval from the Director of Engineering. The detained water cannot be released until the chlorine residual is less than 0.01 ppm (mg/L).
7. Operation – The process delineated above will be reiterated until passing water sample test results are received. Upon receipt of the passing water sample tests, the City construction inspector will work with the Public Works Department to place the new system into operation.

### 5.3. Wastewater Design Criteria

#### 5.3.A. General

1. Design criteria for all wastewater systems shall comply with the current edition of the TCEQ Chapter 217 (Design Criteria for Domestic Wastewater Systems).
2. Wastewater main sizes shall comply with the Wastewater Master Plan.
3. For utility billing purposes, wastewater service shall not be provided to a lot unless said lot also has water service.
4. Wastewater mains shall be sized and extended through the limits of a development to serve adjacent properties.
5. Larger lines shall not flow into smaller lines
6. Wastewater systems shall be designed so that all wastewater mains will be gravity flowlines. If the use of a wastewater lift station is approved by the Director of Engineering, it shall be designed in accordance with **Section 5.4**.
7. All wastewater flows shall remain in their respective drainage basins unless expressly approved by the Director of Engineering.
8. Connections to substandard mains and manholes shall not be allowed. Substandard mains shall be determined by the Director of Engineering based on criteria including, but not limited to: size, material, condition, flow rate, capacity, etc. Offsite improvements may be necessary to provide adequate wastewater service to the site.

#### 5.3.B. Sewer Services

1. General – The sizes and locations of service laterals shall be designated as follows:
  - a. All sewer services shall be extended to a point 10 feet beyond the property line at a maximum depth of 5 feet.
  - b. Cleanouts shall be placed at the ROW/property line for all services.
2. Single Family Residential
  - a. Service lateral size shall be 4 inch minimum at a 2 percent minimum grade for each lot or unit from the cleanout near ROW/property line to main.
  - b. One service lateral per lot or each unit. Duplexes and/or townhomes shall have two 4 inch service laterals that shall be independently attached to the main.
  - c. Service laterals shall be installed at the center of the lot or duplex unit and shall have a minimum horizontal separation of 10 feet from the water service.

- d. Service laterals shall connect directly to the public sewer main. Service laterals shall not connect directly to a manhole.
  - e. The engineer shall review the finish pad elevations, depth of service lateral lines, slopes from pad to street to verify the sanitary sewer system can serve all properties within the sanitary sewer basin.
3. Multi-Family Residential
- a. Service lateral size shall be 6 inch minimum. Minimum grade shall be per the current edition of the International Plumbing Code.
  - b. A minimum of 1 service lateral per building shall be required.
  - c. Service laterals shall have a minimum horizontal separation of 10 feet from the water service.
  - d. Service laterals shall connect directly to a manhole.
4. Non-Residential
- a. A minimum of 1 service lateral per building shall be required.
  - b. Service laterals shall have a minimum horizontal separation of 10 feet from the water service.
  - c. Service lateral size shall be 6 inch minimum. Minimum grade shall be per the current edition of the International Plumbing Code.
  - d. Service laterals shall connect directly to a manhole.

#### 5.3.C. Design Flow

- 1. All wastewater collection systems shall be designed in accordance with the current Wastewater Master Plan.
- 2. Where possible, all collection systems will be laid out so that all lines will be gravity flow unless approved by the Director of Engineering.
- 3. Residential development submittals shall include the total number of units and the total acres for the proposed development. Non-residential development submittals shall include total building square footage, the planned use for the building, and total acres for the proposed development. The projected wastewater flows shall be calculated and shown in MGD in accordance with the Wastewater Master Plan and per TCEQ Chapter 217 (Design Criteria for Domestic Wastewater Systems). A sanitary sewer basin map and sizing analysis shall be provided for sewer mains that serve more than 300 single family units, 400 multi-family units, or an equivalent combination of those uses or other uses.

All wastewater collection systems must be designed to convey the peak wet weather flow from the entire service area including offsite areas throughout the

system. Basin delineation shall be provided using NCTCOG, LIDAR, or surveyed contours. Contours shall be provided on 2 foot or less intervals. USGS topo is not permissible.

4. Flow calculations must include the specifics of the average dry weather flow and the dry weather flow peaking factor.

#### 5.3.D. Sizing Wastewater Collection Mains

##### 1. General

- a. The engineer shall contact the Director of Engineering to obtain contact information for the City consultant maintaining the City’s wastewater collection system model and/or determine the size of wastewater main required from the Wastewater Master Plan.
- b. The standard wastewater main sizes that shall be used are noted in the **Table 5-6**.

**Table 5-6 – Standard Wastewater Main Sizes**

8 inch	10 inch	12 inch
15 inch	18 inch	21 inch
24 inch	27 inch	30 inch
33 inch	36 inch	39 inch
42 inch	48 inch	54 inch
60 inch	----	----

##### 2. Average Daily Flow

- a. **Table 5-7** shall be used to calculate the average daily wastewater flow. The collection system shall be designed based on the peak flow calculations.
- b. For replacement of existing sewer and construction of parallel sewers for additional capacity, wastewater flow data will be provided by the Director of Engineering from data generated by the Wastewater Master Plan computer model developed by the Director of Engineering.
- c. Wastewaters with direct connections to service lines shall be designed to be no more than 70% full and interceptors shall be designed for 80% full.
- d. Proposed parallel wastewater mains adjacent to existing wastewater mains shall be sized to eliminate surcharge in the existing lines.

- e. **Table 5-8** summarizes the non-residential land use demand rates. Land uses not listed shall be classified by the land use they most nearly resemble in **Table 5-8** or calculated by the engineer in accordance with the anticipated use. The engineer shall submit the average daily demand and peak flow calculations including off-site flows within the drainage basin to the Director of Engineering for review and approval.

**Table 5-7 – Residential Wastewater Flows by Land Use**

District	Land Use	Estimated Units Per Acre	Population Per Unit	Average Daily Flow at 100 gpcd (gpad)
R43	Estate	1.0	3.2	320
R12	Single Family	2.7	3.2	864
R8	Single Family	4.1	3.2	1,312
R6	Single Family	5.4	3.2	1,728
R5	Single Family	6.5	3.2	2,080
TR1.8	General – Townhome	18.1	2.0	3,620
FR	General	9.0	2.5	2,250
MR	General	18.0	2.0	3,600
MF30	Multi-Family Low Density	22.5	2.0	4,500
MHR	Mobile Home Park	8.0	2.0	1,600

**Table 5-8 – Non-Residential Wastewater Flows by Land Use**

Land Use	Average Daily Flow
Town Center Redevelopment	3,500 gpad
Town Center Downtown	1,500 gpad
Ex. Retail/Office, Fut. Town Center Mix, Neighborhood Comm, Prof. Campus / Employ. Mix, Entertain Ctr & Mixed Use Center, Restaurant	1,500 gpad
Institutional – Schools, Hospitals, Nursing, Government, etc.	1,500 gpad
Future Manufacturing & Warehousing / Employ Mix Comm. Center, Comm Center,	1,400 gpad
Exist. Industrial & Future Manufacturing & Warehousing	1,000 gpad
Entertainment Center	1,500 gpad
Professional Campus	1,700 gpad
Professional Campus / Comm. Center	1,300 gpad
Exist. Open, Amenity Zone & Parks	150 gpad
Town Center Mix	1,800 gpad
Urban Living	300 gpad
Utilities & Airport	300 gpad

*gpad – gallons per acre per day*

*Source: 2019 Wastewater Collection System Master Plan Update*

3. Peak Flow Factor – Peak flow factors are as follows:
  - a. For average daily flow less than 0.05 MGD – Peak Flow Factor = 5.
  - b. For average daily flow between 0.05 MGD and 1.0 MGD – Peak Flow Factor = 4.
  - c. For average daily flow between 1.0 MGD and 2.0 MGD – Peak Flow Factor = 3.5.
  - d. For average daily flow greater than 2.0 MGD – Peak Flow Factor = 3.

#### 5.3.E. Inflow and Infiltration

1. After determining the peak flow amount, the engineer shall add an average daily inflow and infiltration rate of 650 gpad.

2. Clay trench dams are required per the City of McKinney Construction Standard Details. Trench dams are required for all mains 12 inches in size and greater and at all locations with high groundwater, such as creeks, lakes, etc.

#### 5.3.F. Horizontal Alignment and Vertical Alignment

1. The following guidelines shall be used for the placement of wastewater mains:
2. Horizontal curves will be allowed along centerlines of curved residential streets. Minimum radius of curve and maximum deflection angle of pipe joints will be restricted to 75 percent of manufacturer's recommendation, after which the use of a manhole will be required for a change in alignment.
3. Vertical curves are not allowed.
4. For new construction in open space areas, sewer mains shall be laid straight between manholes.
5. When the locations are known, services for future lots shall be installed.
6. Alignment should follow the centerline of ROW and/or easements.
7. No wastewater main shall be placed under pavement on divided arterial roadways.
8. For main replacement projects, when flow permits, 8 and 10 inch mains should be replaced in the same alignment.
9. Public wastewater mains shall not be located nearer than 8 feet from any tree. Reference **Section 7** for additional landscape requirements within the ROW.
10. No wastewater mains shall be located in alleys.
11. Where pipes enter a manhole, there shall be a minimum of 0.10 foot of drop between flowlines. Where unequal size pipes enter a manhole, crown of pipes shall match elevations of the connecting pipe with the highest crown elevation.
12. Wastewater mains deeper than 12 feet with service connections will require a second shallower parallel main to convey wastewater to the nearest downstream manhole
13. The minimum acceptable Manning's "n" value for use in wastewater design shall be 0.013. Pipes shall be placed on such a grade that the velocity complies with current City's desired minimum and maximum criteria summarized in **Table 5-9**.

**Table 5-9 – Grades for Wastewater Mains**

Pipe Diameter (inches)	Minimum Slope (percent)	Maximum Slope (percent)
8	0.76	8.40
10	0.56	6.23
12	0.44	4.88
15	0.33	3.62
18	0.26	2.83
21	0.21	2.30
24	0.17	1.93
27	0.15	1.65
30	0.13	1.43
33	0.11	1.26
36	0.10	1.12
39	0.09	1.01
>39	**	**

\*\* For pipes larger than 39 inch diameter, the slope can be determined by Manning's formula to maintain a flow velocity greater than 2.0 feet per second and less than 10.0 feet per second when the pipe is flowing full. Manning's formula is as follows:

$$V = \frac{1.486}{n} (R)^{2/3} (S)^{1/2}$$

Where:

- V = flow velocity (feet per second)
- n = Manning's roughness coefficient (dimensionless)
- R = hydraulic radius, which is the area of the flow divided by the wetted perimeter ( $R = A/P$ ) (feet)
- A = flow area (square feet)
- P = wetted perimeter (feet)
- S = pipe slope (feet per foot)



### 5.3.G. Depth of Cover

1. The depth for the design of sewer mains shall be determined by providing a 2 percent grade for the service lateral from the center of the house or building to the center of the proposed main and including an additional 2 foot drop from the finish floor elevation.
2. When establishing depth for proposed wastewater mains, engineer shall evaluate proposed street grades and anticipate the size of proposed storm sewers in unimproved areas. Future storm sewers should be at least 3 feet below the top of pavement. The proposed wastewater main shall be at least 2 feet below the bottom of the future storm sewer. Minimum cover shall be 4 feet. Any main with less than minimum cover shall be encased in Class "G" embedment and is subject to approval by the Director of Engineering. Refer to **Section 5.1.F.4** for additional requirements for shallow cover at creek crossings.
3. The service lateral within the ROW must have at least 3 feet of cover at its shallowest point. The engineer is responsible for insuring that sufficient depth and grade is maintained to serve all proposed and future building sites in the sewer shed.
4. The engineer shall consider the ultimate roadway elevations in determining the depth of cover. Additional depth of cover shall be required for future development and as directed by the Director of Engineering.
5. Depth of cover greater than 12 feet must be approved by the Director of Engineering. In no cases shall sewer mains located underneath public roadways have a depth of cover greater than 15 feet.

### 5.3.H. Manhole Locations and Manhole Sizes

1. Manholes shall be designed based on the following requirements and in the following locations:
  - a. A manhole shall not be located in the flow path of a watercourse, or in an area where ponding of surface water is probable. Additional manholes may be required as determined by the Director of Engineering.
  - b. At each end of lines that are installed for aerial crossings and siphons.
  - c. At the location of service lateral connections that are 6 inch diameter or greater.
  - d. Spacing shall be limited to 500 feet. TCEQ mains with horizontal curvature shall have a maximum spacing of 300 feet per TAC Title 30, Part 1, Chapter 217, Subchapter C, Rule 217.53.
  - e. At all locations where diameter of the pipe changes.
  - f. At all locations where pipe material changes.

- g. At all locations where the horizontal or vertical alignment of the sewer main changes.
- h. At the beginning and end of horizontal curves.
- i. At the end of wastewater collection system pipes. Provide pipe stub outs with plugs for future connections that may be extended in the future.
- j. Manhole testing shall be in accordance with ASTM 1244.
- k. Existing brick manholes shall be replaced.
- l. Manholes installed on existing sewer mains shall be cast-in-place. Manhole installed on new sewer mains shall be precast.

## 2. Floodplains

Bolt down sanitary sewer manhole lids with gaskets shall be used to prevent the entrance of stormwater when manholes are placed within the limits of the fully developed 100-year floodplain. Where more than three manholes in sequence are to be bolt down sanitary sewer manhole lids with gaskets, every third manhole shall be vented 2 feet above the fully developed 100-year floodplain elevation or 6 feet above the adjacent ground line, whichever is higher. The engineer shall obtain and provide the elevation of the fully developed 100-year floodplain. Sealed manholes shall also be used in all areas subject to carrying drainage flow or in drainage ways. Refer to **Section 4** of this manual for methodologies to determine the limits of the fully development 100-year floodplain.

## 3. Manhole Lids and Rims

Reference the City of McKinney Construction Standard Details for additional requirements for standard lids and, bolt down sanitary sewer manhole lids with gaskets.

## 4. Manhole Sizes

- a. Manholes to be constructed on existing or proposed sewer lines shall be sized as shown in **Table 5-10**.
- b. Manholes deeper than 15 feet shall be a minimum of 5 feet diameter and require structural design. Manholes deeper than 20 feet require approval from the Director of Engineering. Manhole diameter may increase due to pipe geometry, excessive depths, and multiple pipes connected to the manhole. Special manholes shall be designed for mains larger than 36 inch diameter pipe and for mains greater than 15 feet deep. 18 inch minimum measured outside diameter to outside diameter of pipe along the outside surface of the wastewater manhole shall be maintained between pipes to manhole connections. If the 18 inch separation cannot be achieved a larger diameter manhole shall be selected to meet these requirements.

- c. The manhole invert channels and benches shall be manufactured in the precast plant with the manhole bottom section. The invert channels shall be sloped to maintain a smooth transition through the manhole connecting all inlets and outlets without the need of further field modifications.

**Table 5-10 – Manhole Diameter Requirements**

<b>Pipe Diameter</b>	<b>Manhole Minimum Diameter</b>
8 inch through 12 inch	4.0 feet
15 inch through 27 inch	5.0 feet
30 inch through 36 inch	6.0 feet

- 5. Drop Manholes – Drop manholes shall be required when the inflow elevation is more than 24 inches above the outflow elevation. New drop manholes shall be constructed with inside drops with a 6 foot minimum diameter. Depending on the depth of the drop manhole and inside clearances between drop bowl apparatus and the manhole, the Director of Engineering may increase the minimum diameter above 6 feet. Drop manholes shall increase in diameter as necessary to accommodate the pipe for an internal drop connection as necessary to provide 48 inches of clear space for construction and maintenance operations. Within the manhole the inverts shall be sloped to maintain a smooth transition through the manhole connecting all inlets and outlets. Outside drop connections will not be allowed.
- 6. For all existing manholes that are disturbed during construction that are fiberglass or otherwise substandard, manhole shall be rehabbed or replaced to meet current standard. Manholes that are determined to be structurally sound shall be structurally lined.
- 7. Corrosion Protection for Manholes
  - a. Apply structural (Sprayroq, structural liner, or approved equal) polyurethane coating material to all exposed new interior surfaces in sanitary sewer manholes and wet wells. Apply a structural polyurethane coating material to all exposed interior surfaces in existing/rehabbed sanitary sewer manholes and wet wells. Surface preparation and protective coating material (PCM) shall follow manufacturer’s recommendations.
  - b. Approved corrosion protection shall be provided for:
    - i. All wastewater manholes for 15 inch and greater line sizes.
    - ii. First wastewater manhole on line connecting to 15 inch or greater line.
    - iii. Force main transition manholes.
    - iv. All drop manholes.

### 5.3.I. Pipe Material

1. The specification of pipe material is the responsibility of the engineer based on the analysis of specific site, soil conditions, loading conditions, and pressure requirements. The following guidelines are based on pipe size only and in no way relieve the engineer of the responsibility of pipe material specifications applicable to the particular project and restrictions due to special construction methods.
2. Allowable pipe materials for gravity mains are shown in **Table 5-11**.
3. Additional specifications for the pipes referenced in **Table 5-11** are as follows:
  - a. For water and wastewater separation deficiencies, wastewater pipe shall be:
    - i. (8 inch-15 inch) PVC Pressure Pipe Class 160 SDR 26 (ASTM D2241) or Ductile Iron AWWA C151 Pressure Class 350, internal ceramic liner and green polyethylene encased. Ceramic liner to be manufactured by Protecto 401 or HDPE, AWWA C901/C906, DIPS minimum DR13.5 (160 psi), ASTM D2239, ASTM D2737, ASTM D3035, ASTM F714 and ANSI/NSF 14/61 listed.
    - ii. (18 inches and larger) – Green PVC Pressure Pipe Class 160 SDR 26 (ASTM D2241) or Ductile Iron AWWA C151 Pressure Class 350 (internal ceramic liner and green polyethylene encased). Ceramic liner to be manufactured by Protecto 401 or HDPE, AWWA C901/C906, DIPS minimum DR13.5 (160 psi), ASTM D2239, ASTM D2737, ASTM D3035, ASTM F714 and ANSI/NSF 14/61 listed.
    - iii. For water and wastewater TCEQ separation deficiencies (larger than 18 inches) – FRP with recommended Structural Number (SN) and Pressure Class Number (PN) (150 psi minimum) or HDPE, AWWA C901/C906, DIPS minimum DR13.5 (160 psi), ASTM D2239, ASTM D2737, ASTM D3035, ASTM F714 and ANSI/NSF 14/61 listed.
  - b. HDPE Pipe
    - i. HDPE pipe size selection needs to account for the pipe wall thicknesses to meet the internal diameters listed within **Table 5-11**, internal pressures, and depth of bury.

**Table 5-11 – Pipe Materials for Gravity Mains**

Internal Diameter Pipe Size	Pipe Material
4 inch through 15 inch	<ul style="list-style-type: none"> <li>• Green PVC, SDR 26 (Pipe Class 160 psi) or 35 (ASTM D3034). Fittings shall be equivalent to pipe class.</li> <li>• 4 inch and 6 inch pipe for sanitary sewer laterals shall be green, PVC, SDR (Pipe Class 160 psi).</li> <li>• Green stripe HDPE, AWWA C901/C906, DIPS minimum DR 21 for line depths less than 10 feet, DIPS minimum DR 17 for depths 10 feet and greater, ASTM D2239, ASTM D2737, ASTM D3035, ASTM F714 and ANSI/NSF 14/61 listed.</li> <li>• Ductile Iron, AWWA C151 Pressure Class 350, internal ceramic liner and green polyethylene encased. Ceramic liner to be manufactured by Protecto 401 or approved equal.</li> </ul>
18 inch and larger	<ul style="list-style-type: none"> <li>• Solid Wall Green PVC, ASTM F679.</li> <li>• Fiberglass Reinforced Pipe (FRP) is acceptable for 24 inch diameter and larger lines. FRP with recommended Structural Number (SN) and Pressure Class Number (PN). Documentation shall be provided by the manufacturer indicating a minimum of 2 years of successful production of FRP in the U.S.</li> <li>• Green stripe HDPE, AWWA C901/C906, DIPS minimum DR 21 for line depths less than 10 feet, DIPS minimum DR 17 for depths 10 feet and greater, ASTM D2239, ASTM D2737, ASTM D3035, ASTM F714 and ANSI/NSF 14/61 listed.</li> </ul>
30 inch and larger	<ul style="list-style-type: none"> <li>• Solid Wall Green PVC, ASTM F679.</li> <li>• FRP with recommended Structural Number (SN) and Pressure Class Number (PN). Documentation shall be provided by the manufacturer indicating a minimum of 2 years of successful production of FRP in the U.S.</li> <li>• Green stripe HDPE, AWWA C901/C906, DIPS minimum DR 21 for line depths less than 10 feet, DIPS minimum DR 17 for depths 10 feet and greater, ASTM D2239, ASTM D2737, ASTM D3035, ASTM F714 and ANSI/NSF 14/61 listed.</li> </ul>

Notes: For piping that does not have the green material for wastewater applications, the pipe shall be spiral wrapped with appropriate detectable or non-detectable caution tape. The spiral wrapping shall be on 2 feet centers measured along the pipe.

The selected pipe material used in construction shall be noted on all plan and profile sheets in the Record Drawings.

4. For trench depths greater than 10 feet or other dead and/or live loading considerations, the engineer shall provide a pipe with the appropriate SDR rating which shall meet or exceed SDR 26 pipe specifications. The Director of Engineering may issue written approval for use of Ductile Iron AWWA C151

Pressure Class 350 (internal ceramic liner and polyethylene encased). Ceramic liner to be manufactured by Protecto 401 or approved equal.

5. Additional specifications for the above referenced pipes are as follows:
  - a. Ductile Iron Pipe – All buried metal shall be wrapped per AWWA C105/A21.5 ASTM 674 polyethylene tube wrap.
  - b. Different pipe materials are not allowed between manholes.
  - c. The material used for the wastewater shall be designed for a minimum structural life cycle of 50 years. If the pipe material will deteriorate when subjected to corrosive conditions, the engineer shall provide for an acceptable corrosion resistant liner or provide calculation and data that demonstrates that the design and operational characteristics will provide for the minimum life cycle.
  - d. All gravity sewer pipes shall be green in color. PVC fittings may be either green or white in color.
  - e. All pipes with encasings shall be restrained joint pipes for all applications.

#### 5.3.J. Pipe Embedment

1. The type of embedment and backfill for sewer mains shall in accordance with the City of McKinney Construction Standard Details.
2. Trench Dams may be required by the Director of Engineering depending on the ground water potential, pipe slope and length of sloped line segments.

#### 5.3.K. Cleanouts

1. Residential cleanouts located on service laterals shall be 4 inch diameter and located on the property line/ROW line.
2. Cleanouts on residential sewer services are to be located and installed as per approved drawings, building code requirements, and City of McKinney Construction Standard Details.
3. Cleanout installations must pass all applicable testing requirements outlined for gravity collection pipes in TCEQ Chapter 217.57 (Testing Requirements for Installation of Gravity Collection System Pipes).
4. Cleanouts shall not be used on City maintained collection systems unless otherwise approved by the Director of Engineering.
5. Cleanouts shall be provided on service laterals with locator pad and tape to surface at the property line.

### 5.3.L. Connections to Existing Wastewater Mains

1. When connecting a 6 inch or larger new line to an existing wastewater main the engineer shall provide a new manhole at the point of connection. Prior to breaking into the existing line the new manhole and upstream pipe segment shall pass inspection by the Director of Engineering.

### 5.3.M. Abandonment of Wastewater Mains

1. The engineer shall specify on the plans the limits and appropriate conditions for abandoning existing wastewater mains that are to be replaced by the construction of proposed wastewater mains.
1. The engineer shall ensure that the service laterals tying into the existing sewer line to be abandoned are transferred to the new main so a live sewer main is not abandoned. If a manhole on the sewer main being abandoned is to remain in service because other sewer mains are entering this manhole, then the sewer main to be abandoned shall be plugged inside the manhole. A note on the plans showing which sewer main is to be plugged inside the manhole is required.
2. Abandonment of wastewater mains shall be in accordance with the City of McKinney Construction Standard Details. All abandoned wastewater and force main lines shall be cut and plugged and all void spaces within the abandoned line shall be filled with grout, flowable fill or an expandable permanent foam product in accordance with the Utilities Approved Materials List in the Construction Standards and Specifications Manual.
3. Mains being abandoned within 50 feet of the corner clip right-of-way of existing or future arterial intersections are to be removed rather than abandoned in place.
4. Abandonment of all utilities within TxDOT ROW shall comply with TxDOT standards.



## 5.4. Wastewater Lift Station Design Criteria

### 5.4.A. General

1. The use of a wastewater lift station shall be approved by the Director of Engineering. Lift stations shall be designed as permanent installations. Lift stations shall be designed to exceed the minimum requirement established in TCEQ Chapter 217.59 (Lift Station Site Requirements) and the requirements of this section. Lift stations will only be allowed after all other alternatives for transporting wastewater flows have been investigated and the lift station is found to be the best alternative for the service area. The Director of Engineering reserves the right to review each proposal and determine whether there is enough merit to justify a lift station.
2. A preliminary design submittal will be required for each proposed lift station. The submittal shall include a typed report, all lift station, force main, and odor control design calculations, plans, and a basin map prepared by a registered professional engineer in accordance with the Plan Review Development Checklist in **Appendix B**.

### 5.4.B. Site Selection and Requirements

1. Site Selection – The following are the minimum criteria that shall be met for a lift station site.
  - a. The station should be located as remotely as possible from populated areas. The lift station site shall not be located within 150 feet of an existing or proposed residential dwelling and 100 feet from a residential lot.
  - b. The station site and its access shall be dedicated to the City as a wastewater easement. The fencing set back shall be 20 feet from the easement line to allow for a landscape and drainage buffer.
  - c. The station site shall be located so it may serve as much of the entire sewer drainage basin as possible. This may require that the station be located off-site of the development. When a station serves a larger area than the proposed development, the developer may enter into a pro-rata agreement with the City to be reimbursed the cost of excess capacity as other developments connect to the system.
2. Site Access
  - a. Access will be provided by a concrete surface from a public street and/or dedicated access easement. Concrete shall be a minimum 6 inches thick, 4,000 psi reinforced concrete pavement with a minimum of 15 feet in width and 50 feet in length to allow maintenance vehicles to park fully outside of the City ROW designed in accordance with **Section 2**.
  - b. Access drives shall be an approved Fire Department standard turnaround with applicable turning radii when located on existing and future thoroughfares and



all other locations when pulling out becomes a safety hazard. The alignment of the drive shall allow maintenance vehicles the ability to back up straight to the wet well.

- c. The station shall be accessible during the fully developed 100-year flood and FEMA 100-year flood. The elevation of the site shall be a minimum of 2 feet above both the fully developed 100-year floodplain and the FEMA 100-year floodplain in accordance with **Section 4**.

### 3. Site Security

- a. At a minimum, security of the lift station site shall be provided by an intruder-resistant fence (IRF) to restrict access by an unauthorized person(s). The IRF shall be placed around the perimeter of the site encompassing all interior structures and apparatuses and shall maintain a 3 foot clearance from all lift station components.
- b. The IRF shall consist of a minimum 8 foot high solid screening device that complies with the Unified Development Code. If landscaping is provided in accordance with the tubular steel or wrought iron screening device option, the landscaping and irrigation system shall be owned and maintained by the property owner. A minimum 16 foot wide slide gate consisting of tubular steel or wrought iron shall be provided for access.

### 4. Site Interior

- a. Interior shall be a minimum 6 inches thick reinforced concrete pavement designed in accordance with **Section 2**. Site shall be graded to drain away from the station to prevent storm water inflow or infiltration into the wet well. The wet well top elevation shall be a minimum of 6 inches higher than interior concrete to provide wheel stop for maintenance vehicles.
- b. Control panel shall have a 3 foot minimum clear working area away from face of cabinet. Electrical and Instrumentation Panels shall be located where they do not obstruct vehicle access to the wet well or the dry well. They shall be placed at an elevation so that they are easily accessible.
- c. A 15 foot high halogen area light with photometric cell on an aluminum pole shall be placed within 10 feet of wet well and control panel without obstructing daily operations.
- d. Hoisting equipment shall be provided when the ultimate sized pump weight exceeds 2,500 lbs. Hoisting equipment shall be outdoor/weather rated, electric and capable of lifting selected pumps onto a 54 inch high truck bed or trailer with minimal manual assistance.
- e. Provide a 1 inch potable freeze-proof water service with a 1 inch angle stop and double check valve shall be installed in an appropriately sized meter box.

#### 5.4.C. Wet Well and Valve Vault Design

1. Wet Well Design – Wet well shall be cast in place or pre-cast watertight and gas tight walls with watertight joint meeting ASTM C478-90. Steel, and RCP are not acceptable materials. The tops may be pre-cast with the hatches built in. Sanitary sewer manhole rim elevations upstream of wet well shall match or exceed top of wet well design elevation. All wall penetrations through the wet well wall shall be gas tight. The wet well shall be hydrostatically tested to the top of the wet well for 48 hours prior to putting the lift station into service. Only losses due to evaporation will be tolerated. Additional design requirements are as follows:
  - a. Orientation
    - i. Orientation shall consider the routing of incoming sewer and force main for ease of maintenance and to minimize effluent turbulence.
    - ii. Orientation shall allow a 5 ton vehicle to pull in forwards or backwards directly to the wet well or the dry well.
    - iii. All influent gravity mains discharging into the wet well shall be located so that the invert/flowline is above the “on” setting liquid level of the pumps.
  - b. Level Sensors
    - i. Liquid level sensors shall be ENM-10 level regulators switch or approved equal. Sensors shall be provided for “All Pumps Off,” “Lead Pump On,” “Lag Pump On,” and “High Level Alarm” levels as well as additional “Lag-Lag Pump On” for lift stations with more than two pumps.
    - ii. Level Sensors shall be placed in a stilling well.
    - iii. The location of a wet well water level mechanism must ensure that the mechanism is unaffected by currents, rags, grease, or other floating materials.
    - iv. A wet well water level mechanism must be accessible without entering the wet well.
  - c. Wet Well and Valve Vault Separation – Wet wells and valve vaults shall be a common slab separated by expansion joint. The wet well and valve vaults shall have separate entrances.
  - d. Liner and Coatings
    - i. Wet wells shall have a minimum of 10 percent sloped bottoms to the pump intakes and shall have a smooth finish to avoid excess sludge deposits.
    - ii. Wet wells shall be structurally sprayed with Sprayroq or approved equal.

- iii. Apply polyurethane coating material to all exposed concrete and grouted surfaces. Surface preparation and PCM application shall follow manufacturer's recommendations.
  - e. Hatches – The wet well shall have a lockable odor suppressing aluminum door with an aluminum frame and safety grate. The minimum opening size shall be 4 feet x 6 feet with 2 doors large enough to adequately maintain the wet well. Door and frame shall be in accordance with the Utilities Approved Materials List in the Construction Standards and Specifications Manual.
  - f. Ventilation
    - i. The design of a wet well must reduce odor potential in a populated area or as directed by the Director of Engineering.
    - ii. Passive ventilation structures shall be provided and must include screening to prevent the entry of birds and insects to the wet well. An air vent pipe shall have a minimum diameter of 4 inches with outlet located 1 foot above wet well top.
    - iii. Continuous mechanical ventilation structures shall be provided with ventilation equipment providing a minimum capacity of 12 air exchanges per hour and be constructed of corrosion resistant material. If Average Dry Flow detention time exceeds 4 hours, then an odor control system shall be provided.
  - g. Cable Strain Relief – A stainless steel cable holder shall be provided for all cables in the wet well for cable strain relief purposes.
2. Wet Well Active Volume
- a. The wet well and pump capacity shall be designed for fully developed conditions of the sewer drainage basin using the Peak Wet Weather flows.
  - b. Wet well volume for a submersible pump station is the volume contained above the top of the motor, or as specified by the pump manufacturer.
  - c. High level alarm elevation shall be a minimum of 60 inches below the top of the wet well or 48 inches below the flowline elevation of the lowest service tap, whichever elevation is lower.
    - i. Alarm shall be sent when both pumps are running on a duplex station or when the level is 6 inches to 12 inches over all pumps running. The Director of Engineering shall approve all situations and levels that need to trigger an alarm.

- ii. Wet well volume shall be calculated by the following method:

$$V = \frac{TQ}{4(7.48)}$$

Where:

- V = active volume (cubic feet)  
 Q = pump capacity (gallons per minute)  
 T = cycle times (minutes)  
 7.48 = conversion factor (gallons per cubic foot)

- d. Pump cycle time, based on Peak Wet Weather Flow, must equal or exceed the criteria shown in **Table 5-12**.

**Table 5-12 – Minimum Pump Cycle Time**

Pump Horsepower	Minimum Cycle Times
< 50	6 minutes
50-100	10 minutes
> 100	15 minutes

- e. The operation cycle “T” shall not be less than 10 minutes for Average flow and not more than 60 minutes for minimum flow conditions, or half the average daily flow (ADF). The operation cycle time must exceed the manufacturer’s requirements. Overall wet well volume due to a pumping failure shall provide a 2 hour detention time prior to overflow, provided the detained volume is 48 inches below the flowline elevation of the lowest service tap, whichever elevation is lower.
- f. Operation cycle shall be calculated by the following method:

$$T = \frac{V}{Q_{in}} + \frac{V}{Q - Q_{in}}$$

Where:

- T = Time (minutes)  
 V = Active volume of wet well (gallons)  
 Q = Capacity of pump (gallons per minute)  
 Qin = Flow into wet well (gallons per minute)

### 3. Valve Vault

- a. Valve vaults shall have sloped bottoms towards a floor drain to remove liquid build up. The floor drain line from the valve vault connecting to the wet well must prevent gas and liquids from entering valve vault.
- b. The valve vault shall have a lockable aluminum door with an aluminum frame. The minimum opening size shall be 2 feet x 3 feet or large enough to adequately maintain the valve vault. Door and frame shall be in accordance with the Utilities Approved Materials List in the Construction Standards and Specifications Manual. Valve vaults shall be ventilated per Section 5.4.C.1.f.

### 5.4.D. Pumps, Lift Station Piping, and Valves

#### 1. Pumps

- a. Stations shall contain a minimum of two pumps and shall be capable of handling wet weather peak flows with one pump out of service.
- b. All pumps shall be explosion proof, non-clog, submersible type capable of passing a 2-1/2 inch diameter sphere or greater. Vortex impellers shall be used to prevent clogging.
- c. Pumps shall be sized to operate at optimum efficiency. Minimum acceptable efficiency at the operating point will be 60 percent. The minimum required horsepower for the motor must be capable of handling the entire range as shown in the pump curve. Where necessary, a higher horsepower pump will be required to prevent any damage to the motor as a result of loss of hydraulic head situation.
- d. All submersible pumps shall be equipped with an automatic flush valve attached to the pump volute using the hydraulic energy created by the pump operation to temporarily suspend settled materials.
- e. Pumps shall be Xylem Flygt, or approved equal.
- f. The pump rail system shall be MTM Sch 40 stainless steel with supports on 8 feet maximum spacing.

#### 2. Pump Capacity

- a. The firm pumping capacity shall be greater than the wet weather peak flow for the entire drainage basin. If the drainage basin is significantly larger than the proposed development and it is not feasible to design for this flow, the firm capacity may be designed to handle a portion of the basin with the ability to expand for the ultimate basin capacity with approval from the Director of Engineering.

- b. The pump curves shall be selected so that during normal operating conditions the pumps will run near the best efficiency point. The curves shall not approach shut off head when the pumps are running together.
  - c. System head curves, pump curves, and head calculations shall be submitted. Calculations and pump curves at both minimum (all pumps off) and maximum (last normal operating pump on) static heads, and for a C value of both 100 and 140 must be provided for each pump and for the combination of pumps with modified pump curves. Head calculations shall be the sum of static head, friction head in force main and lift station piping, and a fittings head.
  - d. Flow calculations, system curves, and head calculations shall be shown in the construction drawings as well as in a final design report. Final design report shall include all of the preliminary design submittal requirements with the exception of the replacement of final design information.
3. Lift Station Piping
- a. Piping inside the lift station shall be ductile iron meeting AWWA C151. All fittings shall be ductile iron meeting AWWA C110 or C151. Interior of the pipe and fittings shall be lined with American Polybond Plus, which consists of a primer layer of 5 mils thick fusion bonded epoxy and 55 mils thick of modified DuPont Fusabond Polyethylene, or approved equal.
  - b. All nut and bolt assemblies inside the wet well shall be ASTM 316 stainless steel unless otherwise specified.
  - c. Lift station piping shall be designed with an additional emergency by-pass pump connection, allowing the station to be operated with the primary pump(s) out of service for an extended period of time.
4. Valves – Isolation valves, check valves, and air release/vacuum valves shall be located in the valve vault.
- a. Isolation Valves – Each pump shall have one isolation valve downstream of the pump and check valve, including a discharge pressure gauge between the pump and isolation valve. Isolation valves shall be plug valves meeting the City Standard Specifications. The discharge pressure gauge shall be a minimum of 4 inch diameter within the appropriate pressure ranges for the design.
  - b. Check Valves
    - i. Check valves shall be Slambuster, manufactured by J&S Valve Inc., or approved equal.
    - ii. Check valves shall be located upstream of the isolation valve.
    - iii. All external nuts and bolts shall be ASTM 316 stainless steel.

- c. Air Release/Vacuum Valves
  - i. Air release valves of a type suitable for wastewater service shall be installed along the force main where the force main would be prone to trapped air.
  - ii. The type of valve shall be air release or a combination of air release and vacuum breaker. Valves shall be fitted with blow off valves, quick disconnect coupling and hose to permit back flushing after installation without dismantling the valve.
  - iii. The engineer shall determine the valve type and location. The calculations for valve type and valve sizing shall be provided to the Director of Engineering.
  - iv. Isolation valves for 3 inch and smaller air release valves shall be all bronze or brass. Isolation valves 4 inch and larger shall meet McKinney standard specification for resilient wedge gate valve.
  - v. Locations of the air release/vacuum valves shall be shown on the plan and profile sheets for the force main.

#### 5.4.E. Force Main

##### 1. General

- a. Force main capacity shall be sized to meet the pump capacity. The force main may be designed to handle a portion of the basin with the ability to expand for the ultimate basin capacity with the approval from the Director of Engineering. The minimum force main size shall be 4 inch diameter except for grinder pump lift stations. The minimum recommended velocity is 3 feet per second, and the velocity shall not be less than 2.5 feet per second when only the smallest pump is in operation.
- b. Force main sewer pipe shall be designed to meet the working pressure requirements of the particular application. Design calculations and pipe selection shall be submitted to the Director of Engineering.
- c. The force main must terminate below a manhole invert with the top of the pipe matching the water level in the manhole at design flow.
- d. A force main must be designed to abate any anticipated odor.
- e. Allowable pipe materials for force mains are shown in **Table 5-13**.

**Table 5-13 – Materials for Force Mains**

<b>Internal Diameter Pipe Size</b>	<b>Pipe Material*</b>
4 inch through 12 inch	<ul style="list-style-type: none"> <li>• HDPE with green stripe, AWWA C901/C906, DIPS minimum DR 11, ASTM D2239, ASTM D2737, ASTM D3035, ASTM F714 and ANSI/NSF 14/61 listed. HDPE pipe size selection needs to account for the pipe wall thicknesses to meet the internal diameters listed to the left, internal pressures, and depth of bury.</li> </ul>
12 inch and larger	<ul style="list-style-type: none"> <li>• HDPE with green stripe, AWWA C901/C906, DIPS minimum DR 11, ASTM D2239, ASTM D2737, ASTM D3035, ASTM F714 and ANSI/NSF 14/61 listed. HDPE pipe size selection needs to account for the pipe wall thicknesses to meet the internal diameters listed to the left, internal pressures, and depth of bury.</li> </ul>

\*Note: For piping that does not have the green material for wastewater applications, the pipe shall be spiral wrapped with appropriate detectable or non-detectable caution tape. The spiral wrapping shall be on 2 feet centers measured along the pipe.

Note: The selected pipe material used in construction shall be noted on all plan and profile sheets in the Record Drawings.

- f. For trench depths greater than 12 feet or other dead and/or live loading considerations, the engineer shall provide a pipe with the appropriate DR rating which shall exceed the minimum requirements.
- g. All fittings on HDPE pipe shall be fused. If connecting to an existing force main, additional fitting specifications may apply depending on pipe material.
- h. All valves and fittings shall be restrained with Mega-lug or approved equal, unless otherwise noted.
- i. Plans shall include plan and profile for the force main.
- j. Force main shall have a minimum of 4 feet of cover and be laid to standard specifications for potable waterline.
- k. Force main separation and design criteria from water mains and all other utility lines shall meet the minimum requirements from TCEQ Chapter 217 (Design Criteria for Sewerage Systems) and Chapter 290 (Rules and Regulations for Public Water Systems).



- I. All force main contractors shall furnish and install non-metallic pipe detector tape. The detector tape must be located above and parallel to the force main and bear the label "PRESSURIZED WASTEWATER" continuously repeated in at least 1-1/2 inch letters.
  2. Embedment
    - a. The type of embedment for force mains less than 24 inches shall in accordance with the City of McKinney Construction Standard Details.
    - b. Pipe sizes 24 inches and greater the embedment class shall be a function of the pipe material selected including dead and live load considerations provided by the engineer. The engineer shall submit calculations on the embedment selected for the pipe type.
- 5.4.F. Electrical Requirements for New Lift Stations
1. Code Information
    - a. The engineer shall consult with the Building Inspections Department for the latest NEC code requirements.
    - b. Allow a minimum of 3 feet in front of all enclosures to wet well openings for workmen standing space. Observe NEC Article 110 rules for working clearances around the electrical panels.
  2. Electrical Supply
    - a. Electrical services to be 240 volt 3 phase or 480 volt 3 phase.
    - b. Where a single-phase power transformer is required, install a minimum 3 KVA transformer, fused on both the primary and secondary side.
    - c. Install a power phase monitor capable of protecting against phase loss, phase reversal, low voltage, and high voltage.
    - d. Power phase monitor shall have 2 sets of control or alarm contacts. One set used to disable the pump control circuit. The second set used to alarm the RTU of a power failure.
    - e. Install a Flygt MultiSmart Pump Station Management System manufactured by Xylem or approved equal.
    - f. Install SCADA Station Control System. Soft starters are required for lift stations over 90-100 horsepower.
    - g. Install current transformer between the service disconnect and the rest of the electrical equipment to provide a means to monitor the complete station load. Terminate secondary leads on a terminal strip for connection to a future power usage monitor.

- h. Install potential transformer to provide a 120 volt secondary voltage on all 3 phases. Terminate the secondary leads on a terminal strip for connection to a future power usage monitor.
  - i. All electrical power circuits to be protected by circuit breakers (versus fuses) where applicable. As a guide for single-phase circuits use: RTU 15 amp, flow meter/record 15 amp, pump control circuit 15 amp, convenience outlet/flood light 20 amp.
  - j. Shade structure shall be provided. Electrical and SCADA panels shall face north or east (full cover).
3. Pumps
- a. Thermal protection and moisture sending devices in submersible pumps are to be wired to disable pumps and/or control circuits.
  - b. Hand position on H-O-A switch shall be provided and will be capable of operating pump in the event of a complete failure of the level controller.
  - c. The required remote start/stop capability is to be provided by using RTU control module. Install interface relay between RTU contacts pump control circuit. RTU contact operating may be momentary action only.
  - d. Motor starters shall have a normally open auxiliary contact to be used for a pump run contact connected to the RTU.
  - e. Where submersible pump cords are to be installed in conduits, separate dedicated conduits for each pump shall be sized and installed to facilitate removal and re-installation of the pump(s) and pump cord(s).
4. Level
- a. Liquid level sensors shall be ENM-10 level regulators switch or approved equal. Sensors shall be provided for “All Pumps Off,” “Lead Pump On,” “Lag Pump On,” and “High Level Alarm” levels as well as additional “Lag-Lag Pump On” for lift stations with more than 2 pumps.
  - b. Mercury float switch is to be installed and wired as a low level emergency shut off in the event of a continuous pump run due to a level controller failure, pump control switch left in hand position, etc.
  - c. Provide a separate dedicated conduit, sized for the float control cables.
5. Site
- a. Install a weatherproof 20 amp rated 120 volt convenience receptacle outside of the electrical control panel wired to a 20 amp circuit breaker.
  - b. A switch-operated floodlight shall be installed to illuminate control panel area at night.

6. Lightning Protection – Lightning protection shall be provided for the lift station and site, including a grounding system.
  - a. Furnish labor, design, materials, equipment, and incidentals necessary to install a complete lightning protection system in accordance with UL 96A, NFPA 780. Lightning protection system shall be tied to the grounding system for the pump station.
  - b. The system furnished under this specification shall be the standard product of a manufacturer regularly engaged in the production of lightning protection systems and shall be the manufacturer's latest approved design. Listing of the manufacturer in the lightning protection section of the current edition of Underwriters' Laboratories, Inc., Electrical Construction Materials List will be accepted as compliance with this requirement.
  - c. All materials shall be copper and bronze and all of the size, weight, and construction to suit the application where used in accordance with UL, NFPA, NEC code requirements for this type structure and as per manufacturer's recommendations. Class I sized components may be utilized on roof levels 75 feet and below in height. Class II sized components are required for roof levels over 75 feet in height.
7. Dri-Prime Backup System – Install a Dri-Prime Backup System manufactured by Godwin or approved equal. Dri-Prime Backup System to be sized to provide pumping capacity to match buildout Peak Wet Weather flow design for the lift station. Prior to the wye connection to the force main, a Slambuster manufactured by J&S Valve Inc. or approved equal check valve shall be provided with a valve vault.
8. Controls
  - a. All control relays are to be octal 8 pin or 11 pin plug-in type where feasible.
  - b. Three laminated control drawings are to be provided.
  - c. All conduit between wet well and control panel shall be sealed airtight to prevent wet well gases from entering control panel.
  - d. Enclosures shall be mounted on an appropriately sized mounting structure. Mounting structure shall be constructed of 6 inches x 2 inches x 0.25 inches hot dip galvanized steel channel stock. Intersections shall be bolted, not welded with stainless steel fasteners. Aluminum or epoxy coated steel unistrut may be attached to the mounting structure to facilitate placement of enclosures. The legs of the mounting structure shall be set at 24 inch minimum below grade and be encased in concrete.
9. Monitoring – A spare conduit shall be installed between the pump control panel and the RTU enclosure for power usage monitor wiring (1 inch minimum).

10. Cellular shall be provided as primary communications and radio as a backup communication per City of McKinney Requirements.
11. Supervisory Control and Data Acquisition (SCADA) – Modifications to the City’s existing SCADA system will be required with the addition of any new lift station. The City’s SCADA vendor shall provide the work as a subcontractor with the Contractor. Contractor shall supply SCADA equipment per City standards.

5.4.G. Emergency Provisions for Lift Stations

1. Minimum emergency provisions shall comply with TCEQ Chapter 217.63 (Emergency Provisions for Lift Stations).

**5.5. Water and Wastewater Treatment Plant Design Criteria**

- 5.5.A. Water and wastewater treatment for the City and its CCN is provided by the North Texas Municipal Water District. Water and wastewater treatment facilities other than those constructed and maintained by North Texas Municipal Water District are not authorized within the Certificate of Convenience and Necessity (CCN) boundaries of the City of McKinney other than an on-site septic system that serves one residential unit meeting all city, county and state regulations.
- 5.5.B. If a water and/or wastewater treatment facility (not constructed and operated by North Texas Municipal Water District) is authorized, then the design, materials, coatings, and equipment used in the construction and operation shall meet the highest quality of standards for the industry. All design, construction, operation, maintenance, and reporting shall meet or exceed, but not limited to, the standards set forth by Texas Commission on Environmental Quality (TCEQ) rules: Chapter 217 – Design Criteria for Domestic Wastewater Systems and Chapter 290 - Public Drinking Water, American Society for Testing and Material (ASTM) Standards, American Concrete Institute (ACI) Standards, National Science Foundation Standards, and American Water Works Association (AWWA) Standards.

## SECTION 6 STRUCTURAL DESIGN REQUIREMENTS

### 6.1. General

#### 6.1.A. Responsibility

1. The Engineer of Record (engineer) shall bear the sole responsibility for meeting the engineering standard of care for all aspects of the design and providing a design that's required by the site-specific conditions and intended use of the facilities.
2. The structural design must be signed and sealed by an engineer competent in structural engineering licensed in the State of Texas. The engineer is responsible for all engineering and recognizes that specific site circumstances or conditions may require improvements that exceed minimum standards contained in the City's Engineering Design Manual. The engineer is responsible for evaluating and applying appropriate standards and specifications.
3. The engineer shall rely on the geotechnical investigation recommendations as minimum design criteria. If in the engineer's judgment, the structural design needs to be based upon more conservative geotechnical design criteria, the engineer shall provide the more conservative design.

6.1.B. Structures – For the purpose of this section of the Engineering Design Manual, structures shall include the following items, but not be limited to: bridges, foundations, retaining walls, screening walls, headwalls and wingwalls, culverts, slopes and embankments, creek and channel structures, aerial crossings, and other civil structures.

6.1.C. Permitting – A permit is required for the construction of all walls in residential applications for walls 15 inches in height and taller as measured from the top of wall footing to the top of the wall (not the top of the retained fill). For a wall where part of the wall is under 15 inches and part of the wall is over 15 inches, a permit will be required for the entire wall. For commercial and multi-family applications, all walls will require a permit regardless of height. All wall construction plans and specifications submitted to the City for review shall include a permit application submittal.

6.1.D. Inspections – Inspections of structures shall be performed in accordance with **Sections 6.13** and **6.14**. Inspection for structures not performed directly by the City shall be performed by a third-party and include a certification letter signed and sealed by a Professional Engineer licensed in the State of Texas stating that the structure was constructed in general compliance with the City-approved plans and specifications. Any structure outside the public right-of-way and any structure constructed with non-City funds whether inside the public right-of-way or not, shall require third party inspection.

6.1.E. TxDOT Standard Sheets – If TxDOT standard sheets pertaining to structures are utilized, the engineer shall ensure the loading, geometry, and allowable soil pressures are applicable to the standard design selected. The engineer shall ensure that interruptions to the structure (i.e. wall stem or footing reinforcement altered by

openings, utilities, geometric changes, or curved sections of the wall, etc.) do not compromise the design and performance of the structure. Consideration shall be given to the site-specific geotechnical requirements and whether a TxDOT standard design is applicable. No TxDOT standard sheets shall be modified unless the engineer designs, draws, signs, and seals the modified standard. If TxDOT standard sheets are not applicable, a custom structural design shall be provided.

6.1.F. Aesthetics – Aesthetic treatments of structures within the ROW or City-owned facilities are required and shall complement the surrounding features. Aesthetic treatments shall not interfere with the functionality of the structure. Engineer shall consider any potential negative impacts resulting from the structure’s drainage system design. Aesthetic treatments of handrails and guardrails shall comply with all local, state, and federal requirements, including those referenced in **Section 6.2**. Aesthetic treatments shall also comply with the City’s Comprehensive Plan and/or Parks, Recreation, Open Space, Trails, and Streetscape Visioning Master Plan.

#### 6.1.G. Structural Plan Requirements

1. Construction drawings and technical specifications shall be prepared and submitted to the applicable City departments in accordance with **Section 1.9**, the Construction Standards and Specifications Manual, and the Plan Review Development Checklist and Plan Submittal Process provided in **Appendix B**.
2. If applicable, wall quantities and limits of payment shall be submitted in accordance with the City’s technical specifications.
3. Calculations pertinent to the design of all structures shall be submitted to the City along with the construction drawings and will be filed for record purposes by the City. The engineer remains responsible for the design of the structure(s).

### 6.2. Code Requirements

- 6.2.A. At a minimum, all structures shall be designed using the current standards as adopted by the City and shall meet all applicable local, state, and federal standards. For other standards not adopted by the City, the latest version of that standard shall be utilized.
- 6.2.B. The design and construction of roadway bridges and bridge-class culverts shall be provided in accordance with the requirements of the current edition of the *Standard Specifications for Highway Bridges* as published by the American Association of State and Highway Transportation Officials (AASHTO) and supplemented using TxDOT standards and guidelines as applicable.
- 6.2.C. Specifications for bridge construction shall be in accordance with TxDOT’s current edition of *Standard Specifications for Construction and Maintenance of Highways, Streets, and Bridges*.
- 6.2.D. All bridge railing shall be in accordance with TxDOT’s current edition of the *Bridge Railing Manual* and shall meet the specifications outlined in the National Cooperative Highway Research Program (NCHRP) *Report 350*. All railing shall be appropriately

- rated railing based on site and design conditions. Guardrail, end treatments, or other features associated with bridge construction shall be in accordance with AASHTO's current edition of the *Policy on Geometric Design of Highways and Streets*, AASHTO's current edition of *Roadside Design Guide*, and current TxDOT standards. All bridge railing shall meet applicable sight distance requirements.
- 6.2.E. For all bridges and bridge class culverts adjacent to or in conjunction with roadways, sight triangle exhibits shall be submitted to the City for review and approval.
  - 6.2.F. More stringent requirements shall be utilized as required for unusual designs such as rehabilitations, reconstructions, or for unusual site conditions. The codes cannot replace sound engineering knowledge, experience, and judgment.
  - 6.2.G. For any structure, the City or the engineer may require the quality of materials and construction to be higher than the minimum requirements as stated in the codes based on structure usage or site conditions.

### 6.3. Excavation Support

- 6.3.A. Trench excavation protection shall be used for the installation of linear drainage or utility facilities that result in trenches deeper than 5 feet. Such trench protection includes vertical or sloped cuts, benches, shields, support systems, or other systems providing the necessary protection in accordance with *Occupational Safety Health Administration (OSHA) Standards and Interpretations, 29 CFR 1926, Subpart P, Excavations*.
- 6.3.B. Temporary special shoring shall be used for installations of walls, footings, and other structures that require excavations deeper than 5 feet. Temporary special shoring shall be designed and constructed to hold the surrounding earth, water, or both out of the work area. Options may include, but not be limited to, vertical or sloped cuts, benches, shields, support systems, or other systems to provide the necessary protection in accordance with the approved design. Unless a complete design for temporary special shoring systems are included in the plans, the contractor is responsible for the design of the temporary special shoring system. The Contractor must submit to the City, for informational purposes only, the design calculations and details sealed by a Professional Engineer licensed in the State of Texas before constructing the shoring. The design of the shoring must provide protection in accordance with *Occupational Safety Health Administration (OSHA) Standards and Interpretations, 29 CFR 1926, Subpart P, Excavations*.

### 6.4. Geotechnical Performance Specifications

- 6.4.A. Field investigation, geotechnical testing, and geotechnical engineering shall be performed in accordance with the standard of care taking into account local experience and conditions. The geotechnical recommendations shall establish the minimum design criteria upon which the engineer can rely.
- 6.4.B. Right-of-Way (ROW) Permit must be obtained prior to performing any boring within the City's ROW.



- 6.4.C. The complexity of geological conditions and the type, length, and width of the structure shall determine the number and locations of test holes required. The following should be considered by the engineer in coordination with the geotechnical engineer: depth of test hole, location of proposed grade relative to existing grade, channel relocations and/or channel widening, scour, foundation loads, and foundation types.
- 6.4.D. Test holes shall be located in an accessible area. Identify test hole locations on the plans.
- 6.4.E. Provide a complete soil and bedrock classification and log record for each test hole, including all pertinent information to complete the standard log. Location and surface elevation shall be shown on the boring logs.
- 6.4.F. Perform the appropriate field and laboratory tests necessary to determine the soil properties for geotechnical design criteria. The geotechnical engineer shall consider both the short-term and long-term conditions.
- 6.4.G. Ground water elevations shall be included as part of the data acquisition. Site conditions may require the installation of piezometers to establish a true groundwater surface elevation and a method of monitoring water surface fluctuations.
- 6.4.H. Minimum boring requirements are specified below. Based on the geotechnical engineer's experience and engineering judgment, if competent rock is encountered, the minimum boring depths specified below may be reduced with approval from the Director of Engineering.
  - 1. Slopes and Embankments including Bridge Approaches – Obtain soil borings for cuts greater than 10 feet or embankments taller than 10 feet. The exploration shall include the following:
    - a. The soil under future embankments – Advance borings to a depth at least equal to the embankment height or 20 feet, whichever is greater, unless a greater depth is recommended by the geotechnical engineer.
    - b. Soil in proposed cuts – Advance borings to a depth of at least 15 feet below the bottom of the proposed cut, unless a greater depth is recommended by the geotechnical engineer.
  - 2. Bridges
    - a. In general, drill test holes shall penetrate a minimum of 15 feet into proposed bearing strata. Where depth of bearing strata becomes impractical, the Director of Engineering may determine minimum bore depth.
    - b. Test holes shall be drilled near each abutment and bent location of the proposed structure plus a sufficient number of intermediate holes to determine depth and location of all significant soil and rock strata.



- c. A site inspection by the driller or logger shall be performed to evaluate site accessibility and special equipment needs.
  - d. Grade Separations – If the borings indicate soft surface soils (fewer than 10 blows per foot), additional borings and testing shall be required for the design of the bridge approach embankments.
3. Retaining Walls – Obtain soil borings for walls taller than 2 feet.
- a. Obtain a minimum of two soil borings within limits of wall footprint. For walls longer than 200 feet, borings shall be obtained at a maximum spacing of 200 feet unless site conditions or the engineer requires alternate spacing. A greater spacing may be allowed by the Director of Engineering only if recommended in writing by the geotechnical engineer.
  - b. Fill Walls – For spread footing walls and Mechanically Stabilized Earth (MSE) walls, the depth of the boring shall be at least equal to the wall height depending on the wall type. The minimum boring depth is 10 feet below the bottom of the proposed wall unless rock is encountered (see **Section 6.4.H.2**). Extend borings at least 5 feet into rock for fill walls unless additional depth is recommended by the geotechnical engineer.
  - c. Cut Walls – For drilled shaft walls, tied-back walls, and soil and rock nail walls, the depth of the boring shall be based on the proposed ground line. Cantilever drilled shaft walls require the depth of boring to extend to the anticipated depth of the shaft below the cut, which is typically between one and two times the wall height unless additional depth is recommended by the geotechnical engineer. Borings for soil nails, tiebacks, and rock nailed walls shall be advanced through the material that is to be nailed. The minimum boring depth is 15 feet below the bottom of the proposed wall. Borings for proposed cut walls may need to penetrate bearing strata significant distances depending on the depth of the cut and wall height.
  - d. Additional testing and modeling shall be provided for taller walls, walls on slopes, or walls on soft founding strata as necessary or as recommended by the geotechnical engineer to completely evaluate wall stability.

## 6.5. Bridge Design

- 6.5.A. The engineer shall be responsible for selecting the appropriate bridge foundation. The engineer shall consider the following factors in that selection:
1. Design load – The magnitude of the design load and existing geotechnical conditions dictate the required size of the foundation.
  2. Geotechnical engineering recommendations – The strength and depth of subsurface formations determine the type of foundation chosen. In general, drilled shafts are well suited to areas with competent soil and rock, and are the preferred foundation type subject to concurrence from the geotechnical engineer.

Alternative foundation types require approval in writing by the Director of Engineering.

3. Corrosive conditions – Salts, chlorides, and sulfates are detrimental to foundations. Where these conditions exist, the engineer shall take preventative measures. Use sulfate-resistant concrete as applicable.
- 6.5.B. Disregard surface soil in the design of drilled shaft foundations. The disregarded depth is the amount of surface soil that is not included in the design of the foundation due to potential erosion from scour, future excavation, seasonal moisture variation (shrinkage and swelling), lateral migration of waterways, disturbed material or fill, and recommendations of the geotechnical investigation.
- 6.5.C. Drilled shaft capacity relies upon penetrating a specific stratum a specified depth. The plans shall provide a note instructing the contractor and field personnel of the penetration requirement. The plans shall identify the specific type of material to be penetrated and the minimum penetration depth. The plan may allow for the drilled shaft to be shortened if the founding stratum is encountered at a shallower depth, and it requires the shaft to be lengthened if the founding stratum is not encountered at the expected elevation.
- 6.5.D. When the founding stratum is present at or near the surface, the engineer shall consider the load-carrying capacity along with the stability of the superstructure on the foundation. For these conditions, a minimum drilled shaft length shall be specified on the plans and the drilled shaft will not be allowed to be shortened from plan length, but it may be lengthened if the founding stratum is not encountered at the expected elevation.
1. For evaluating scour, TxDOT guidelines in *Evaluating Scour at Bridges (HEC-18)* shall be used.
  2. Bridge foundation scour analysis is required. However, abutments shall be protected against potential scour through use of flexible revetment, where possible or hard armoring.
  3. Design bridge foundations to withstand the scour depths for either the fully developed 100-year flood or smaller flood if it will cause scour depths deeper than the fully developed 100-year flood as described in **Section 4**.
  4. Check the bridge foundations against the scour depth associated with the 500-year flood as described in **Section 4**. This flood event is considered an extreme event and the factor of safety on the bridge foundations shall be greater than or equal to 1.
- 6.5.E. Railing – In addition to the requirements in **Sections 6.1.F** and **6.2**, the following bridge railing criteria shall be met:
1. The face of railing shall be a minimum of 2 feet beyond edge of outside travel lane. Where no sidewalk is present, shoulders shall be flush with the roadway slab.

2. Separation rails shall be provided on all major and minor arterial bridges (as specified in **Section 2**). Separation rails shall not be required on collectors or local streets, or on culverts where the sidewalk is not located adjacent to the back of curb.
  3. Concrete Rail Finish – Formline all vertical surfaces where aesthetic conditions apply with an Ashlar Stone or approved equal pattern. Stain all vertical surfaces. Color(s) shall be approved by the Director of Engineering.
  4. Steel Rail Finish – All rail surfaces shall be powder-coated. Color shall be approved by the Director of Engineering. Refer to **Section 6.1.F**.
- 6.5.F. Pedestrian bridges shall be designed in accordance with **Section 6.5** and the current edition of the LRFD Guide Specifications for the Design of Pedestrian Bridges and the AASHTO *Guide for the Development of Bicycle and Pedestrian Facilities* and shall meet the following additional criteria:
1. Refer to **Section 2.10** for pedestrian facility design requirements.
  2. Loading – Design loads shall be in accordance with the applicable codes outlined in this section and shall include but not be limited to construction loads and surcharge loads from slopes, structures, and specified use (i.e. bicycle, pedestrian, and/or maintenance vehicle traffic).
  3. Plans – Cast-in-place bridge foundations shall be designed for a specified pre-cast bridge structure. The foundation plans and shop drawings for the pre-cast bridge structure shall be submitted for review and approval.
  4. Hydraulics – Refer to **Section 4** for design flood, freeboard, and flood study requirements associated with pedestrian bridge design.
  5. Maintenance – Maintenance considerations of railing for pedestrian bridges that do not contain the fully developed 100-year flood with freeboard (in accordance with **Section 4**) shall be specified in the plans.

## 6.6. Retaining Wall Design

- 6.6.A. The engineer is responsible for ensuring that the type of retaining wall selected for a given location is appropriate. The retaining wall selection process shall consider the following:
1. Height – Walls shall be measured from the top of wall footing to the top of the wall (not the top of the retained fill). An engineered design by a licensed Texas Professional Engineer is required for all walls 24” in height or taller (designed to ensure stability against overturning, sliding, excessive foundation pressure and water uplift and designed for a factor of safety of 1.5 against lateral sliding and overturning in accordance with the International Residential Code). For a wall that has a variable height where part of the wall is under 24” and part of the wall is over 24”, an engineering design will be necessary for the entire wall. For commercial and multi-family applications, all walls will require an engineering

design regardless of height. Furthermore, if any wall has embedded posts, poles, or other structures anchored directly into the wall structure, wall design must also take into consideration the additional loadings due to these structures (axial, lateral, wind, etc.) The structural design shall be provided in accordance with the geotechnical recommendations and minimum design criteria provided in accordance with **Section 6.4.H.3**.

2. Geometry – Determine applicability of wall type – cut, cut/fill, or fill – based on geometry, site constraints, existing and proposed topography, and wall alignment and location. Identify available ROW and any necessary ROW or easements to accommodate the proposed improvements and the access necessary to accommodate access for maintenance. Identify location and type of existing and proposed utilities and drainage structures.
  3. Economics – Evaluate the total installed cost of the wall and consider long-term maintenance requirements. Identify necessary excavation requirements (including shoring), required utility adjustments and costs, project schedule, construction phasing requirements, and these effects on the wall design and construction.
  4. Global Stability – The engineer is responsible for the global stability design of the wall. Evaluate all walls to ensure that the minimum applicable factors of safety are met, if not exceeded depending on the engineer’s judgment. Walls shall not be placed on slopes if avoidable.
  5. Passive Resistance to Sliding – The engineer shall follow the geotechnical engineer’s guidance for use of passive resistance. If there is a slope in front of the wall, passive resistance shall be neglected.
  6. Constructability – Determine whether walls are near water or subject to inundation or groundwater. Identify access limitations for equipment both during and after construction. Ensure adequate horizontal and vertical clearances are provided.
  7. Drainage – Design the wall to prevent the build-up of hydrostatic pressure behind the wall. If conditions warrant such as, but not limited to, the inability to include a drainage system or situations of rapid drawdown, the City may require the wall design to withstand full hydrostatic pressure load. The wall design shall consider potential deleterious short- and long-term effects of water inundation including scour and rapid draw down.
  8. Loading – Design loads shall be in accordance with the Engineering Design Manual, including construction loads and surcharge loads from slopes, structures, and vehicles.
- 6.6.B. Analyze and design walls following accepted geotechnical engineering industry standards for the City of McKinney area and in accordance with the Engineering Design Manual. In analysis, use earth pressures that follow the requirements of the project’s geotechnical investigation specifically addressing the retaining wall design requirements for the project’s specific location.

- 6.6.C. The engineer must ensure that the retaining wall system is appropriate for its location and application. The engineer shall design for all potential modes of wall system failure; including, sliding, overturning, bearing pressure, global stability, and structural capacity of the wall itself.
- 6.6.D. Perched walls shall not be placed on slopes steeper than 8H:1V. When walls must be placed on slopes, or the retaining wall height or the combined wall and slope heights exceed 8 feet, the geotechnical engineer shall conduct a short-term and long-term global stability analysis using applicable soil strength characteristics, geometry, and loading conditions (including load surcharge, hydrostatic, etc.). The engineer is responsible for the design of the wall system, including its global stability.
- 6.6.E. For the purposes of conforming to the Engineering Design Manual, a series of two or more walls built in tiers shall be considered a single wall in height when the base of the upper tier is set back from the base of the lower tier less than two times the height of the lower tier wall.

### **6.7. Slope Stability Design Criteria**

- 6.7.A. All slopes exceeding 8 feet in height with a steepness of 4H:1V or greater, regardless of soil type, cut, or fill, shall be evaluated for global stability for both the short-term and the long-term conditions. Additionally, any known areas of existing fill, deleterious material, or soft soils which have a height over 4 feet or slope angle greater than 6H:1V shall be evaluated for global stability for both the short-term and the long-term conditions. Specific site conditions may require evaluation for additional types of slope failure, such as bearing capacity, settlement, shear, and undercutting. Calculations pertinent to the analysis shall be submitted with the construction drawings when required by the City.
- 6.7.B. Use the following data to analyze global stability of a slope:
  - 1. Geometry (cross section and loading conditions);
  - 2. Location of the water table;
  - 3. Soil/rock stratigraphy; and,
  - 4. Soil/rock properties (unit weight, Atterberg Limits, undrained and drained shear strength).
- 6.7.C. For global stability of a slope, minimum factors of safety must be met for long-term and short-term stability.

### **6.8. Screening Wall Design Criteria**

- 6.8.A. Screening Walls shall meet the minimum requirements included in the Unified Development Code.
- 6.8.B. An opening designed to allow for stormwater drainage shall be provided. The opening shall be a uniform 2 inches high the full length between columns.

## 6.9. Headwalls and Wingwalls

- 6.9.A. Refer to **Section 4.9** for bridge and culvert hydraulic design requirements. Refer to **Section 6.1.E** for use of TxDOT standard sheets.
- 6.9.B. All headwalls and wingwalls shall be reinforced concrete. Wingwalls shall be either "Type A" (parallel wing per TxDOT standard), "Type B" (flared wing per TxDOT standard), or "Type C" (sloped per City of McKinney Construction Standard Details). Approach and discharge aprons shall be provided for all culvert headwall designs.

## 6.10. Culverts

Refer to **Section 6.9** for headwall and wingwall requirements. Refer to **Section 6.1.E** for use of TxDOT standard sheets.

## 6.11. Drop Structures

- 6.11.A. Drop structures are defined as any small dam, weir, or tiered (either vertical or sloped) structure that is placed across a waterway to provide for changes in gradient, slow water velocities and reduce erosion.
- 6.11.B. Refer to **Section 4.8.E** for hydraulic design requirements of vertical and sloping drop structures.
- 6.11.C. The design of drop structures shall be based on the height of the drop, the flow depths upstream and downstream of the drop structure, and the flow rate. All drop structures shall be constructed of reinforced concrete, gabions, or other approved material by the City. To facilitate maintenance, drop structures should be accessible to equipment normally used for maintenance, and as approved by the Director of Engineering.
- 6.11.D. An apron shall be provided immediately upstream and downstream of a drop structure to protect against scour caused by the increasing velocities and turbulence at each drop structure. Apron dimensions shall be site specific and based on velocities. At a minimum, the upstream apron shall extend at least 10 feet upstream from the point where flow becomes supercritical and shall include a cutoff wall into the ground sufficient to protect the structure from scour and hydraulic uplift. The downstream apron shall extend a minimum of 20 feet beyond the anticipated location of the jump and shall include a cutoff wall into the ground. The cutoff wall at each end shall extend below the calculated scour depth or sound bedrock (in accordance with **Section 4** and FHWA HEC-18) but shall be a minimum of 3 feet below channel flowline.

## 6.12. Aerial Crossings

- 6.12.A. Refer to **Section 5.1.F.5** for aerial crossing requirements, including structural design and scour analysis.
- 6.12.B. Stream velocity and impact loading shall be designed in accordance with the requirements of the current edition of the *Standard Specifications for Highway*

*Bridges* as published by the American Association of State and Highway Transportation Officials (AASHTO).

### **6.13. Non-Bridge Construction Inspection and Certification**

6.13.A. Inspections of non-bridge structures shall be performed during construction and reports provided to the City. The inspections and reports shall be performed at the following stages of construction (at a minimum):

1. Sub-base/Pre-pour:
  - a. Drilled shaft drilling and concrete placement (if applicable); and,
  - b. Forming of footing, grade beam, placement of reinforcement (if applicable).
2. Wall construction;
3. Drainage system construction (if applicable); and,
4. Final completion.

6.13.B. Inspector shall certify that construction inspections were performed at the prescribed stages of construction in accordance with **Section 6.13.A**. The inspection reports and final certificate of compliance shall be submitted to the City and include the following:

1. Specific reference to the City-approved plans and specifications;
2. Specific reference to the address and/or legal description for the construction location;
3. Specific reference to the name and date of the project-specific geotechnical engineering report; and,
4. A certification letter signed and sealed by a licensed professional engineer in the State of Texas, that includes a statement that the structure was constructed in general compliance with the geotechnical design criteria identified in the plans and specifications and the City-approved construction plans and specifications.

### **6.14. Bridge Construction Inspection and Certification**

6.14.A. Inspector shall certify bridge construction inspections were performed at the prescribed stages of construction in accordance with the Bridge Construction Inspection and Certification checklist in **Appendix B**.

6.14.B. The inspection reports and final certificate of compliance shall be submitted to the City.



## SECTION 7 LANDSCAPE AND IRRIGATION DESIGN REQUIREMENTS

### 7.1. General

7.1.A. The purpose of this section is to provide additional requirements and standards to address landscaping and irrigation requirements only within the medians and right-of-way (ROW) of public roadways. Refer to the following ordinances and documents:

1. City of McKinney Unified Development Code or as Amended
2. [Tree Permit Requirements Checklist](#)
3. [Irrigation Checklist for Final Inspections](#)
4. [Irrigation Permitting Procedures](#)
5. [Approved Irrigation Evapotranspiration \(ET\) Controllers List](#)
6. [Parks, Recreation, Open Space, Trails, and Streetscape Master Plan](#)
7. Parks, Recreation, and Open Spaces Irrigation Parts Specifications (Request the most recent edition from the Parks and Recreation Department)

7.1.B. Landscape construction plans shall be prepared and sealed by a Registered Landscape Architect, Architect, or Professional Engineer with a license to practice within the State of Texas.

7.1.C. Irrigation construction plans shall be prepared and sealed by a Licensed Irrigator licensed within the State of Texas.

7.1.D. Refer to the Unified Development Code for approved plant materials. Refer to the list of approved canopy and ornamental trees within ROW provided in **Section 7.2**. Refer to the Approved Materials List for approved irrigation equipment in the Construction Standards and Specifications Manual.



## 7.2. Landscape Requirements within Right-of-Way

### 7.2.A. General Requirements within ROW

1. Sight Distance and Visibility
  - a. Rigid compliance with landscaping requirements shall not be such as to cause visibility obstructions and/or blind corners at intersections.
  - b. Whenever an intersection of two or more streets or driveways occurs, a visibility triangle shall be created in accordance with **Section 2**. Landscaping within the visibility triangle shall be designed to provide unobstructed cross-visibility between two feet and seven feet in height. Canopy trees may be permitted in this area provided they are trimmed in such a manner that no limbs or foliage extend into the cross-visibility area and trees have not been planted that the trunks of the trees themselves provide obstruction by how they are aligned and grouped.
  - c. Multi-trunk and ornamental trees shall only be allowed in the ROW with City approval. Multi-trunk and ornamental trees shall be outside visibility triangles.
  - d. Landscape maintenance shall strictly adhere to all sight distance and visibility requirements. Refer to **Section 2** for additional sight distance and visibility requirements with regards to landscaping and other obstructions at intersections.
2. Trees and planting areas shall not be installed on slopes steeper than 4H:1V.
3. Sod shall be placed to cover all disturbed areas within public right-of-way. Temporary erosion control measures may be utilized in lieu of sod in residential subdivisions adjacent to residential lots.
4. Areas not required to be sodded shall be seeded after properly preparing the ground as designated on the plans and in accordance with Technical Specifications.
5. Artificial plants are prohibited.
6. All trees planted within 5 feet of a curb must include a rigid plastic root barrier approved by the City. Root barriers shall be used for trees within a parkway between the curb and the tree itself.
7. Trees within ROW shall be limited to the approved canopy and ornamental trees provided in **Tables 7-1** and **7-2**.
8. Trees overhanging walks and parking shall have a minimum clear trunk height of 7 feet. Trees overhanging public street pavement drive aisles and fire lanes shall have a minimum clear trunk height of 14 feet.

**Table 7-1 – Canopy Trees Approved Within Medians and Parkways**

Common Name	Latin Name
Chinese Pistache	<i>Pistachia chinensis</i>
Chinquapin Oak	<i>Quercus muhlenbergii</i>
Red Oak	<i>Quercus shumardi</i>
Texas Red Oak	<i>Quercus shumardi</i> 'Texana'
Cedar Elm	<i>Ulmus carassifolia</i>
Lacebark Elm	<i>Ulmus parvifolia</i>
Drake Elm	<i>Ulmus parvifolia</i> 'Drake'

**Table 7-2 – Ornamental Trees Approved Within Medians and Parkways**

Common Name	Latin Name
Desert Willow	<i>Chilopsis linearis</i>
Possumhaw Holly	<i>Ilex deciaua</i>
Crape Myrtle	<i>Lagerstroemia indica</i>
Vitex	<i>Vitex agnus-castus</i>
Yaupon Holly	Form <i>Ilex vomitoria</i>

\*\*\*Additional species may be approved upon review.

#### 7.2.B. Requirements within the Median

1. Conduit for street lighting and irrigation shall be generally located as shown in the City of McKinney Standard Details to accommodate landscaping within the median.
2. No trees shall be installed in the location of future travel or turn lanes. Refer to **Section 2** for roadway typical sections.
3. Landscaping that is located within the median of a public roadway shall meet the minimum requirements shown in **Table 7-3**.

**Table 7-3 – Median Landscaping Requirements**

<b>Median Width (feet)</b>	<b>Landscaping Requirements</b>
< 8	Hardscape components only.
8 to 12	Mowed grass. Ground cover shall not exceed 1 foot in height.
> 12	Mowed grass, shrubs, or trees. Ground cover (exclusive of trees) shall not exceed 2.5 feet in height.

**7.2.C. Requirements within the Parkway**

1. A minimum of 4 inches suitable loam topsoil shall be furnished and installed for all seed and sod areas within the parkway.
2. Only mowed grasses shall be permitted within 6 feet of the existing or future face of curb along the parkway.

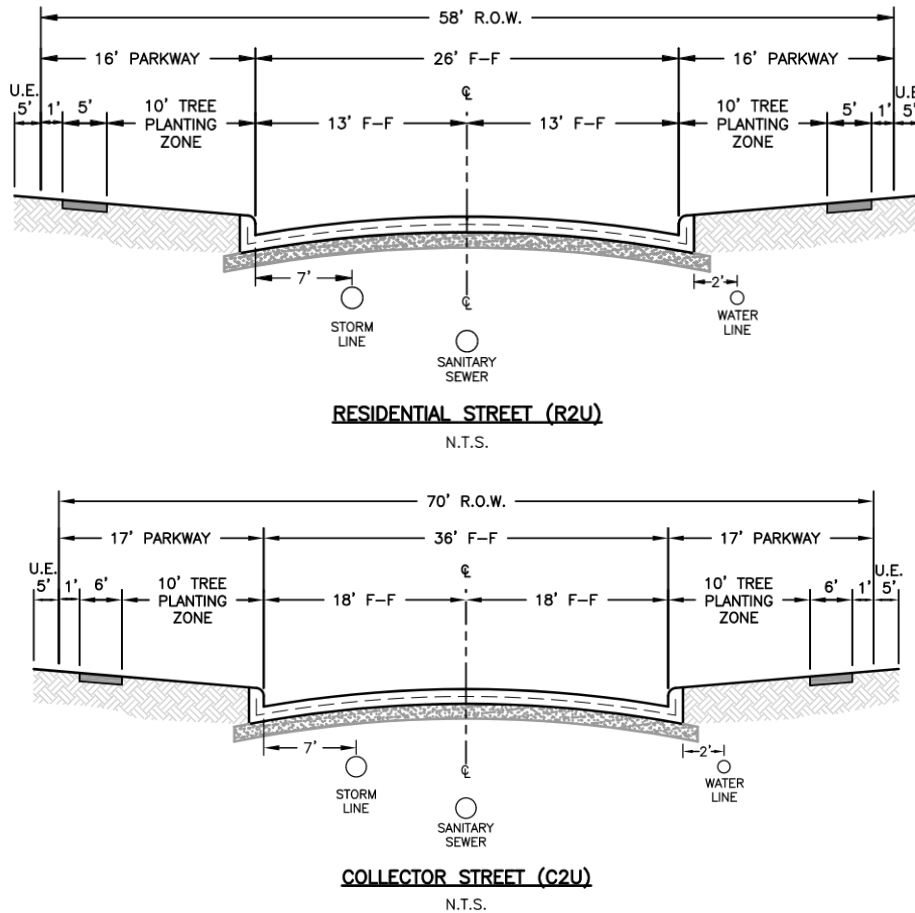
**7.3. Irrigation Design Requirements within Right-of-Way**

- 7.3.A. Irrigation system shall be designed and installed to minimize runoff onto paved surfaces. Overspray on streets and walks are prohibited.
- 7.3.B. Engineer shall contact the Parks Department for the most recent irrigation standards.
- 7.3.C. Median conduit systems shall be designed in accordance with the City of McKinney Standard Details.

**7.4. Street Trees**

- 7.4.A. For the purposes of this section, Street Trees shall include any tree planted within public right-of-way or private street easement between the back of curb and the sidewalk. Street Trees shall only be allowed where authorized by the Zoning Ordinance, or in other situations where explicitly authorized by the Director of Engineering and the Director of Planning. Street Trees shall only be allowed on residential and collector roadways. Street Trees shall not be allowed on arterial roadways, nor within TxDOT right-of-way.
- 7.4.B. Where Street Trees are proposed, the entire proposed subdivision shall comply with this section unless there is a clear separation between phases created by a collector roadway with no residential frontage, arterial roadway, or open space. Side frontages, HOA lots, parks, school sites, and non-residential uses within the proposed subdivision shall also include street trees.

7.4.C. Where Street Trees are proposed, the modified typical sections shown in in **Figure 7-1** shall be used in lieu of the typical sections found in Section 2 of this manual. Where special sections are proposed, such as divided streets or streets with protected parking lanes, the typical section shall be expanded to include a minimum 10-foot tree planting zone and a minimum 5-foot utility easement outside the right-of-way, in addition to any other requirements of this manual.



**Figure 7-1 – Street Tree Typical Sections**

7.4.D. Street Trees shall be separated from utilities, curbs, sidewalks, and other improvements as noted in **Table 7-4**. Where minimum separation requirements cannot be met, the Director of Engineering and the Director of Planning may consider alternate separation requirements or alternate planting locations as a variance to these standards.

**Table 7-4 – Street Tree Separation Requirements**

<b>Improvement</b>	<b>Minimum Distance to Street Tree (to center of trunk / root ball)</b>
Water Mains	3 feet
Water taps, fittings, meters, services, fire hydrants, and other appurtenances	8 feet
Sewer Lines, including services	8 feet
Storm Lines and Inlets	3 feet
Franchise Utilities (underground, surface)	3 feet
Franchise Utilities (overhead)	20 feet
Sidewalks	4 feet
Street (from back of curb)	4 feet
Residential Driveways (from edge of pavement)	10 feet
Commercial / Multi-Family Driveways (from edge of pavement)	25 feet
Alley Intersections (from edge of pavement)	25 feet
Street Intersections (from edge of pavement)	50 feet
Existing or Future Signalized Intersection (from edge of pavement)	100 feet
Traffic Signs and Street Lights	20 feet
Other Trees	30 feet

- 7.4.E. Street Tree spacing (tree-to-tree) shall be as specified in the Zoning Ordinance. Where no spacing is given in the Zoning Ordinance, Street Trees shall be spaced at approximately one tree per 50 feet of street frontage, with adjustments allowed for the separation distances noted above. In no case shall two trees be located less than 30 feet apart.
- 7.4.F. A Street Tree Planting Plan shall be included with the civil engineering plans for review, based on the typical sections, separation distance, and spacing noted in this section. Once approved with the civil engineering plans, the Street Tree Planting Plan shall also be submitted with the Final Plat for the subdivision for record purposes. Street Trees proposed adjacent to HOA lots shall be planted with the initial subdivision construction and verified by the Director of Planning. Street Trees proposed adjacent to residential lots shall be planted with the home construction and verified by the Chief Building Official. Street Trees proposed adjacent to parks, school sites, and non-residential lots shall be planted with the site construction and verified by the Director of Planning. It is the responsibility of the developer to provide the tree planting plan to individual home builders, general contractors, and others to insure compliance with the approved plan. Street Trees found to not be in compliance with this section shall be removed and replaced at the developer or property owner's expense.
- 7.4.G. Street Trees shall be maintained by the adjacent property owner in accordance with Section 70-56 of the City of McKinney Code of Ordinances. The developer may enter into a License Agreement with the City to have the HOA be responsible for street tree maintenance. The City or their designee(s) shall have the right, but not the obligation, to trim or remove trees as necessary for safe and efficient operations of streets, utilities, and other services, or for public safety purposes.

## **SECTION 8 ENVIRONMENTAL DESIGN REQUIREMENTS**

### **8.1. General**

8.1.A. The Owner must provide proof of compliance with applicable federal, state, and local environmental regulations upon request by the City of McKinney (City). Potential applicable regulations and permits may include, but are not limited to:

1. Section 404 of the Clean Water Act (33 USC 1344);
2. Section 106 of NHPA;
3. Water Rights;
4. Section 303(d) impaired waters;
5. Migratory Bird Treaty Act;
6. Water Well Drilling;
7. Threatened and Endangered Species Act;
8. The Texas Archeological and Research Laboratory Requirements;
9. The Antiquities Code of Texas;
10. Air Quality; and,
11. TCEQ Dam Requirements.

8.1.B. Erosion Control Plan – An Erosion Control Plan (ECP) is required for all sites regardless of size. The ECP shall consider areas where development activities or channel improvements occur and shall protect these areas from site erosion. Sediment carried by stormwater runoff through these areas shall be prevented from entering storm drain systems and natural watercourses through applicable Best Management Practices (BMPs). The owner should refer to the Civil Engineering Plan Review Development Checklist included in Appendix B for Erosion Control Plan requirements. The owner may also consult with the North Central Texas Council of Governments (NCTCOG) for a list of BMPs to control site erosion but should also comply with the City’s Erosion and Sediment Control Manual and the current General Notes provided in the Construction Standards and Specifications Manual. It is the responsibility of the Engineer of Record (engineer) to select and design appropriate construction controls for each site. If the most appropriate control is not shown in the current edition of the NCTCOG integrated Stormwater Management (iSWM™) Technical Manual, the engineer shall submit calculations and references for design of the control to the Director of Engineering for review and approval. Some acceptable forms of site erosion control devices include, but are not limited to, silt fences, silt traps, geo-netting, and geo-textiles. The minimum design storm for temporary BMPs is the 2-year, 24-hour storm event.

## **8.2. Texas Construction General Permit and City Requirements**

8.2.A. Although Environmental Protection Agency (EPA) Region 6 still has regulatory authority concerning stormwater discharges in Texas and surrounding states, the Texas Commission on Environmental Quality (TCEQ) has issued Construction General Permit (CGP) TXR150000 to regulate stormwater discharges from construction sites. These requirements are modified and amended from time to time. Prior to beginning construction on any site, the engineer, developer, and contractor should make themselves aware of the current EPA, TCEQ, and City requirements. Construction activities are regulated according to the area of land disturbed. Refer to the CGP for definitions of the Primary Operator and Secondary Operator.

Common Plan of Development –

1. A construction activity completed in separate stages, phases, or in combination with other construction activities
2. Identified by documentation showing the scope of the construction project.
3. Documentation may include plats, blueprints, marketing plans, contracts, building permits, zoning requests, etc.

8.2.B. Large construction activities:

For sites that disturb 5 or more acres, or are part of a larger common plan of development that will disturb 5 or more acres, the following applies:

1. Prepare and implement a Stormwater Pollution Prevention Plan (SW3P).
2. Submit a Notice of Intent (NOI) to TCEQ.
3. Submit a copy of the NOI and CSN to the Engineering Department at least two days prior to construction.
4. Post the Large Construction Site Notice (CSN) where it is readily viewed by the general public during all construction activities.
5. Submit a Notice of Termination (NOT) to both the State and the Engineering Department upon permanent stabilization and BMP removal.

8.2.C. Small construction activities:

For sites that disturb at least 1 acre, but less than 5 acres, or are part of a larger common plan of development that will disturb at least 1 acre, but less than 5 acres, the following applies:

1. Prepare and implement a SW3P.
2. Submit a copy of the CSN to the Engineering Department at least two days prior to construction.



3. Post a Small Construction Site Notice (CSN) where it is readily viewed by the general public during all construction activities.
4. Once the site is permanently stabilized and BMPs have been removed, the CSN shall be signed and dated. A copy of this shall be provided to the Engineering Department.

8.2.D. Less than 1-acre construction activities:

Projects that disturb less than 1 acre do not require an NOI or a TCEQ CSN but are still required to provide a City of McKinney CSN and associated ECP. These must be approved by the Director of Engineering two days prior to initiation of construction activities.

**8.3. Stormwater Pollution Prevention Plan – Temporary Controls**

- 8.3.A. One of the requirements of the CGP is to develop a SW3P. The purpose of the SW3P is to provide guidelines for minimizing sediment and other pollutants that may originate on the site from flowing into municipal storm systems or jurisdictional waters of the U.S. during construction. The plan must also address the principal activities known to disturb significant amounts of ground surface during construction.
- 8.3.B. The stormwater management controls included in the SW3P should focus on providing control of pollutant discharges with practical approaches that use readily available techniques, expertise, materials, and equipment. The SW3P must be implemented prior to the start of construction activities.
- 8.3.C. Construction Controls – Structural controls and general site practices may be used for controlling pollutants for stormwater discharges from small and large sites. Structural controls shall comply with details and specifications in the current edition of the NCTCOG iSWM™ Technical Manual for Construction Controls, these standards, and the City’s Construction Standards and Specifications Manual. When the NCTCOG Technical Manual and City standards are in conflict, City standards shall govern. The following are acceptable temporary controls for use during construction:
  1. General Site Practices
    - a. Minimizing the area of disturbance; and,
    - b. Preserving existing vegetation.

2. Structural Controls
    - a. Silt fence;
    - b. Inlet protection;
    - c. Rock check dams;
    - d. Stabilized construction exits;
    - e. Sediment traps;
    - f. Vegetated buffer strips;
    - g. Sedimentation basins; and,
    - h. Hydromulch.
  3. Additional construction controls can be found in the NCTCOG iSWM™ Construction Controls Manual.
  4. Temporary sedimentation basins are required for drainage areas greater than 10 acres of disturbed area. Sedimentation basins shall not be located in the 100-year fully developed flood plain.
  5. Temporary controls must include methods to reduce dust from the construction site. This may include wetting haul roads or areas of excavation prior to beginning work.
- 8.3.D. Waste and Hazardous Material Controls – Covered containers shall be provided for waste construction materials and daily trash. Hazardous materials shall be stored in a manner that prevents contact with rainfall and runoff. Onsite fuel tanks and other containers of motor vehicle fluids shall be placed in a bermed area with a liquid tight liner or be provided with other secondary containment and spill prevention controls. The SW3P shall require federal, state, and local reporting of any spills and releases of hazardous materials greater than the regulated Reportable Quantity (RQ) and reporting to the Director of Engineering of all spills and releases to the storm drainage system.
- 8.3.E. Temporary Stabilization
1. Portions of a site that have been disturbed, but where no work will occur for more than 21 days, shall be temporarily stabilized as soon as practicable, and no later than 14 days after soil disturbance activities have ceased, except when precluded by seasonal arid conditions or prolonged drought.
  2. Temporary stabilization shall consist of providing a protective cover designed to reduce erosion on disturbed areas. Temporary stabilization may be achieved using temporary seeding, soil retention blankets, hydromulch, and other techniques that cover 100 percent of the disturbed areas until either final stabilization can be achieved or until further construction activities take place.

3. Perimeter controls such as silt fence, vegetated buffer strips, or other similar perimeter controls are intended to act as controls when stabilization has not occurred. Perimeter controls may remain in place during temporary stabilization.

#### 8.3.F. Inspection and maintenance during construction

1. The owner shall construct all controls required by the SW3P. The owner shall have qualified personnel inspect the controls either every two weeks during construction and within 24 hours after a storm event of 0.5 inches, or once a week until final acceptance.
2. Certified inspection reports shall be retained as part of the SW3P. Within 24 hours of the inspection, controls identified as damaged or deteriorated shall be repaired or replaced, as appropriate. Controls shall also be routinely cleaned to maintain adequate capacity.
3. Changes or additions to the SW3P or ECP by the Operator shall be implemented within 24 hours to prevent discharges from the site. The owner shall implement procedures to remove discharged soil from all portions of the storm drainage system including streets, gutters, inlets, storm drain, channels, creeks, and ponds.
4. Notes requiring the inspection and maintenance shall be placed on SW3P drawings. The SW3P shall identify the responsible party for inspecting and maintaining each control. If no party is identified, each owner and Operator that submitted an NOI for the site shall be fully responsible for implementing all requirements of the SW3P.

- 8.3.G. Final Stabilization – Stabilization measures that provide a protective cover must be initiated immediately in portions of the site where construction activities have permanently ceased. Final stabilization consists of soil cover such as vegetation, geo-textiles, mulch, rock, or placement of pavement or concrete. Final stabilization through vegetation will require 100% coverage at 70% density. For stabilizing vegetated drainage ways, sod or seeded soil retention blankets shall be used. Hydromulch will not be allowed in vegetated swales, channels, or other drainage ways. Temporary controls from all disturbed areas shall be removed and permanent stabilization shall be established and accepted by the City prior to final acceptance and issuance of a CO. The plan for final stabilization shall be coordinated with permanent controls in the PCSQP (see **Section 8.4**) and with the landscaping plan (see **Section 7**), if applicable.

8.3.H. Notice of Termination – All parties that submitted an NOI shall submit an NOT within 30 days after final stabilization is established. Temporary controls shall be removed, and permanent stabilization shall be established and accepted by the City prior to submitting an NOT. When the owner of a residential subdivision transfers ownership of individual lots to builders before final stabilization is achieved, the SW3P shall include controls for each individual lot in lieu of final stabilization. These controls shall consist of stabilization of the right-of-way and placement of structural controls at the low point of each individual lot or equivalent measures to retain soil on each lot during construction. Additionally, the builder must submit a valid NOI before an NOT can be submitted by the owner.

**8.4. Post Construction Stormwater Quality Plan – Permanent Controls**

- 8.4.A. General Requirements – A Post Construction Stormwater Quality Plan (PCSQP) shall be prepared for all developments with plans that disturb a surface area of 1 acre or greater. The PCSQP shall be in accordance with the checklist in **Appendix B** and shall be developed and coordinated with the site drainage plan and may be shown on the same sheet. The PCSQP shall identify permanent site BMPs that will be constructed with the project to minimize and mitigate the project’s long-term effects on stormwater quality and quantity. The PCSQP shall include a combination of structural and non-structural BMPs that protect water quality and are appropriate for the community, per TPDES General Permit TXR040000 Part III Section B.4.(a).(2). The PCSQP should also be coordinated with the landscaping plan (see **Section 7**) to prevent conflicts and ensure compatible land use.
- 8.4.B. Number of Permanent BMPs Required – **Table 8-1** provides the minimum number of permanent controls required for a site. As conveyance BMPs such as Inlets, Storm Sewer Systems, etc. do not provide water quality protection as required by TCEQ, they shall not count towards the Post-Construction BMP requirements.

**Table 8-1 – Minimum Number of Permanent BMPs Required**

Area Disturbed	Minimum Number of Permanent Water Quality BMPs
1 acre ≤ Disturbed Area < 10 acres	2
10 acres ≤ Disturbed Area < 20 acres	3
≥ 20 acres	4

8.4.C. Permanent Site Development Controls – It is the responsibility of the engineer to design permanent controls, or BMPs, that address site specific conditions using appropriate design criteria for the North Central Texas region. Refer to the below referenced McKinney approved list of Site Development Controls. This information can also be found in the current edition of [NCTCOG iSWM™ Technical Manual for Site Development Controls](#) for applicability and specific design information.

1. Some of the factors to be considered when evaluating and selecting controls for a development are as follows:
  - a. Impact of the development on runoff volumes and rates
  - b. Potential pollutants from the development
  - c. Percent of site treated by the control
  - d. On-site natural resources
  - e. Configuration of site (including existing waterways and topography)
  - f. Maintenance requirements for the control
  - g. Soil classification and infiltration

8.4.D. Approved Water Quality BMP List

**Structural Water Quality BMPs**

1. Bio-retention Areas\* - Structural stormwater control that captures and temporarily stores the water quality volume (WQv) using soil and vegetation in shallow basins or landscaped areas to remove pollutants from stormwater runoff.
2. Enhanced Swales – vegetated channels engineered to capture and treat the water quality volume (WQv) for a drainage area and designed with limited longitudinal slopes to force the flow to be slow and shallow, thus allowing for particulars to settle and limiting the effects of erosion.
3. Organic Filters – design Variant of the surface sand filter using organic materials in the filter material in the filter material.
4. Planter Boxes – used to impervious surfaces in highly urbanized areas to collect and detain infiltrate rainfall and runoff. The boxes may be prefabricated or constructed in place and contain growing medium, plants, and a reservoir.
5. Downspout Dry Well – perforated manholes, but they can be manufactured in various sizes. Located underground, they allow stormwater infiltration even in highly urbanized areas. They should be used in conjunction with some type of pretreatment devices where there are minimal risks of groundwater contamination.

6. Infiltration Trenches – excavated trench filled with stone aggregate used to capture and allow infiltration of stormwater runoff into the surrounding soils from the bottom and sides of the trench.
7. Soakage Trenches – variation of infiltration trenches. Soakage trenches drain through a perforated pipe buried in gravel. They are used in highly impervious areas where conditions do not allow surface infiltration and where pollutant concentrations in runoff are minimal. They may be used in conjunction with other stormwater devices, such as draining downspouts or planter boxes.
8. Stormwater Pond – constructed stormwater retention basin that has a permanent pool (or micropool). Runoff from each rain event is detained and treated in the pool primarily through settling and biological uptake mechanisms.
9. Green Roofs – a green roof uses a small amount of substrate over an impermeable membrane to support a covering of plants. The green roof slows down runoff from the otherwise impervious roof surface as well as moderating rooftop temperatures. With the right plants, a green roof will also provide aesthetic or habitat benefits. Green roofs have been used in Europe for decades.
10. Rain Harvesting – rain harvesting is a container or system designed to capture and store rainwater discharged from a roof. The rain harvesting system consists of a storage container, a downspout diversion, a sealed lid, and an overflow system. Typical rain harvesting systems hold between 50 and 500 gallons of water and may work in series to provide larger volumes of storage.
11. Wetlands, stormwater – constructed wetland systems used for stormwater management. Runoff volume is both stored and treated in the wetland facility.
12. Wetlands, submerged gravel – subsurface flow wetland, this wetland consists of one or more cells filled with crushed rock designed to support wetland plants. Stormwater flows subsurface through the root zone of the constructed wetland where pollutant removal takes place.
13. Grass Channels – vegetated open channels designed to filter stormwater runoff and meet velocity targets for the water quality design storm and the “Streambank Protection” storm event.
14. Detention, Dry/ Extended Dry – A surface basin or facility designed to provide water quantity control through detention and/or extended detention of stormwater runoff.
15. Filter Strip – uniformly graded and densely vegetated sections of land engineered and designed to treat runoff from and remove pollutants through vegetative filtering and infiltration.
16. Inlet Catch Baskets – manufactured baskets installed inside the lip of curb inlets to catch floatables and other debris. Shall not be installed on public roadways.

17. Hydrodynamic Devices – designed to remove settleable solids, oil and grease, debris, and floatables from stormwater runoff through gravitational settling and trapping of pollutants. Shall not be installed on public storm lines.
18. Proprietary Systems – manufactured structural control systems available from commercial vendors designed to treat stormwater runoff and/or provide water quality control.

Performance data and design perimeters will need to be submitted for review and approval

### **Non-Structural Water Quality BMPs**

19. Natural Preserve - must meet the following:
  - a. Natural preserve can be divided into 2 areas max with each area having a 20' minimum preserve width.
  - b. Natural preserve must consist of plants native to the local North Texas area. The area must be clearly identified as a preserved area of land on civil plans and plats.
  - c. At a minimum, must cover at least 7 percent of the development area.
20. Preservation of the 100-year Floodplain - must meet the following:
  - a. No disturbance or reclamation of the 100-year fully developed floodplain or FEMA floodplain, whichever is larger.
  - b. Any damage or impact during or subsequent to construction to the designated natural creek area will require remediation of the area back to a natural state. Final acceptance for the site will not be processed until remediation has been completed, inspected and approved.
21. Preservation of Natural Creeks - must meet the following:
  - a. There will be a no disturbance area extending from 50 feet beyond top of bank on either side of the natural creek.
  - b. Any damage or impact during or subsequent to construction to the designated natural creek area will require remediation of the area back to a natural state. Final acceptance for the site will not be processed until remediation has been completed, inspected and approved.
22. Open Space – must meet the following:
  - a. No side of the qualifying usable open space shall be less than 50 feet.
  - b. Must be in the boundary of the plated site and shall not overlap with any other post-construction BMPs.

- c. Must comprise at least 10 percent of the platted area.
  - d. Must follow any other regulations related to Open Space requirements.
23. Scheduled Site Cleanup - must be;
- a. Conducted quarterly,
  - b. Documented through log and photos, and
  - c. include the entire platted area for commercial, or entire common area for residential.
24. Adopt a street/stream – must be;
- a. A street adjacent to site the with a speed limit <40mph
    - 1. Conducted quarterly,
    - 2. Documented through log and photos, and
    - 3. include the entire right of way area along the platted property side of the street, plus 100' beyond the property limits.
  - b. A stream or stream bank within the platted area
    - 1. Conducted quarterly,
    - 2. Documented through log and photos, and
    - 3. An area of no less the 10,500ft.sq. for commercial, or
    - 4. Along the entire length of the common area for residential
25. Fertilizer/Pesticide Management – must;
- a. Include a fertilizer/pesticide chemical management plan submitted to the city and subsequently implemented,
  - b. Allow only persons with appropriate applicators license to implement plan, and
  - c. Document through log, application and storage inspection dates.
26. Stormwater Inlet Marking – must;
- a. Include installation of City approved inlet markers,
  - b. Install markers at all private storm inlets within platted area, and
  - c. Have a plan to replace lost or damaged markers.



#### 8.4.E. General Maintenance Requirements for Non-Structural BMPs

1. Non-structural areas shall be preserved, and no structure, construction, storage, fill, or alteration may occur within the area.
2. Motor vehicles/heavy equipment should be avoided to reduce compaction of the soil.
3. Minor maintenance to maintain the natural state of the preserved area is allowed, such as:
  - a. Removal of diseased or invasive plants,
  - b. Replanting of native vegetation to replace invasive plants,
  - c. Filling and stabilizing eroded areas,
  - d. Streambank stabilization work is allowed, though efforts should be made to minimize compaction of the soil and damage to the native preserve area.
4. Herbicides, pesticides, and harsh chemicals should not be used in the preserved area. Spot treatment to manage invasive plants is allowed if performed under the supervision of a landscape professional.

#### 8.4.F. Construction and Maintenance

The owner shall construct all permanent controls in accordance with this section and is responsible for maintenance of the controls. When the control falls within a drainage easement, the plat or separate instrument dedicating the easement shall include a statement of the owner's responsibility for maintenance.

#### 8.4.G. Required Notes on Plat

1. Post-Construction BMP maintenance requirements should be summarized and labeled on all non-conveyance plats.
  - a. List the type of permanent BMPs established on site
  - b. Identify the iSWM™ standards or proprietary standards
  - c. List the responsible party for BMP maintenance.
  - d. An easement must be dedicated via plat for all non-structural BMPs.

Post-Construction BMPs maintenance requirements

1. Bioretention Area-maintenance as listed in iSWM™ revision 2014
2. Enhanced Swale-maintenance as listed iSWM™ Revised 2014

Responsible party of post-construction maintenance is  
XXXXXXXX – Owner of Property

Category	On-Site Storm Water Controls	STORM WATER TREATMENT SUITABILITY				WATER QUALITY PERFORMANCE				SITE APPLICABILITY				IMPLEMENTATION CONSIDERATIONS							
		Water Quality Protection	Streambank Protection	On-Site Flood Control	Downstream Flood Control	TSS/ Sediment Removal Rate	Nutrient Removal Rate (TP/TN)	Bacteria Removal Rate	Hotspot Application	Drainage Area (acres)	Space Req'd (% of tributary imp. Area)	Site Slope	Minimum Head Required	Depth to Water Table	Residential Subdivision Use	High Density/Ultra Urban	Capital Cost	Maintenance Burden			
Bioretention Areas	Bioretention Areas	P	S	S	-	80%	60%/50%	-	✓	5 max***	5-7%	6% max	5 ft	2 feet	✓	✓	Moderate	Low			
Channels	Enhanced Swales	P	S	S	S	80%	25%/40%	-	✓	5 max	10-20%	4% max	1 ft	below WT	✓		High	Low			
	Channels, Grass	S	S	P	S	50%	25%/20%	-					✓					✓		Low	Moderate
	Channels, Open	-	-	P	S	-	-	-						✓					✓		Low
Chemical Treatment	Alum Treatment System	P	-	-	-	90%	80%/60%	90%	✓	25 min	None				✓	✓	High	High			
Conveyance Components	Culverts	-	-	P	P	-	-	-							✓	✓	Low	Low			
	Energy Dissipation Inlets/Street Gutters	-	P	S	S	-	-	-							✓	✓	Low	Low			
	Pipe Systems	-	P	P	P	-	-	-							✓	✓	Low	Low			
Detention	Detention, Dry	S	P	P	P	65%	50%/30%	70%	✓		2 - 3%	15% across pond	6 to 8 ft	2 feet	✓		Low	Moderate to High			
	Detention, Extended Dry	S	P	P	P	65%	50%/30%	70%	✓		2 - 3%	15% across pond	6 to 8 ft	2 feet	✓		Low	Moderate to High			
	Detention, Multi-purpose Areas	-	P	P	P	-	-	-		200 max		1% for Parking Lot, 0.25 in/ft for Rooftop			✓	✓	Low	Low			
	Detention, Underground	-	P	P	P	-	-	-		200 max						✓	High	Moderate			
Filtration	Filter Strips	S	-	-	-	50%	20%/20%	-		2 max***	20-25%	2-6%			✓		Low	Moderate			
	Organic Filters	P	-	-	-	80%	60%/40%	50%	✓	10 max***	2-3%		5 to 8 ft		✓	✓	High	High			
	Planter Boxes	P	-	-	-	80%	60%/40%	-			6%				✓	✓	Low	Moderate			
	Sand Filters, Surface/ Perimeter	P	S	-	-	80%	50%/25%	40%	✓	10 max***/ 2 max***	2-3%	6% max	5 ft/ 2 to 3 ft	2 feet		✓	High	High			
Hydrodynamic Devices	Gravity (Oil-Grit) Separator	S	-	-	-	40%	5%/5%	-		1 max***	None					✓	High	High			
	Downspout Drywell	P	-	-	-	80%	60%/60%	90%							✓	✓	Low	Moderate			
Infiltration	Infiltration Trenches	P	S	-	-	80%	60%/60%	90%		5 max	2-3%	6% max	1 ft	4 feet	✓	✓	High	High			
	Soakage Trenches	P	S	-	-	80%	60%/60%	90%		5 max	27' per 1000 ft <sup>2</sup> impervious area	6% max	1 ft	4 feet	✓	✓	High	High			
Ponds	Wet Pond	P	P	P	P	80%	50%/30%	70%*	✓	25 min**	2-3%	15% max	6 to 8 ft	2 feet, if hotspot or aquifer	✓		Low	Low			
	Wet ED Pond	P	P	P	P	80%	50%/30%	70%*	✓						✓		Low	Low			
	Micropool ED Pond	P	P	P	P	80%	50%/30%	70%*	✓						✓		Low	Moderate			
	Multiple ponds	P	P	P	P	80%	50%/30%	70%*	✓						✓		Low	Low			
Porous Surfaces	Green Roof	P	S	-	-	85%	95%/16%	-	✓							✓	High	High			
	Modular Porous Paver Systems	S	S	-	-	**	80%/80%	-		5 max	Varies					✓	Moderate	High			
	Porous Concrete	S	S	-	-	**	50%/65%	-		5 max	Varies					✓	High	High			
Proprietary Systems	Proprietary Systems ****	S	S	S	S	****	****	****		****	****				****	✓	High	High			
Re-Use	Rain Harvesting	P	-	-	-	-	-	-							✓	✓	Low	High			
Wetlands	Wetlands, Storm Water	P	P	P	P	80%	40%/30%	70%*	✓	25 min	3-5%	8% max	3 to 5 ft (shallow) 6 to 8 ft (pond)	2 feet, if hotspot or aquifer	✓		Moderate	Moderate			
	Wetlands, Submerged Gravel	P	P	S	-	80%	50%/20%	70%	✓	5 min			2 to 3 ft	below WT	✓	✓	Moderate	High			

✓ - Meets suitability criteria  
P - Primary Control, meets suitability criteria  
S - Secondary Control, can be incorporated into the structural control in certain situations  
\* Provides less than 80% TSS removal efficiency. May be used in pretreatment and as part of a "treatment train"  
\*\* Smaller area acceptable with adequate water balance and anti-clogging device  
\*\*\* Drainage area can be larger in some instances  
\*\*\*\* The application and performance of specific commercial devices and systems must be provided by the manufacturer and should be verified by independent third-party sources and data  
1 Porous surfaces provide water quantity benefits by reducing the effective impervious area  
2 Due to the potential for clogging, porous surfaces should not be used for the removal of sediment or other coarse particulate pollutants

**Table 8-2 –Structural Control Screening Matrix (iSWM Technical Manual-Site Development Controls, April 2010, Rev9/2014)**

## **APPENDIX A**

### **DEFINITIONS AND ABBREVIATIONS**

## DEFINITIONS

The definitions within this section are intended to provide descriptions for terms used within the Engineering Design Manual. When words and terms are defined herein and in other City ordinance(s), they shall be read in harmony. If an irreconcilable conflict exists, the definition contained herein shall control. Where no definition appears, the term should be interpreted according to their customary usage in the practice of municipal planning and engineering. The Director of Engineering has the final determination of interpretation.

Words used in the present tense include the future tense. Words in the singular tense include the plural tense. The word “shall” is mandatory and not directory. The word “may” is directory and not mandatory.

**100-year** – A flood event that statistically has a recurrence interval (return period) of 100 years and a one percent chance of being equaled or exceeded in any given year. The event shall be based upon fully developed watershed conditions unless otherwise specified.

**Alley** – A public or private way set aside as a permanent right-of-way for the movement of vehicular traffic. An alley is meant to provide access to abutting property, provide utility service, and has a right-of-way with an ultimate width of 20 feet or less.

**Applicant** – Any firm, entity, partnership, company, public utility company, or individual that submits a formal request or application.

**Arterial Street** – A roadway designed to carry high volumes of through traffic and serves as a link between major activity centers within the urban area.

**Arterial Trail** – A trail with a typical width ranging from 10 feet to 12 feet that follows a street and is separated from motor vehicle traffic. Arterial Trails have a slightly lower level of amenities than Spine Trails. Arterial Trails are also less likely to have fully grade-separated crossings of streets; however, grade-separated crossings are desirable when crossing principal arterials and state highways.

**Auxiliary Lane** – A lane striped for use as an acceleration lane, deceleration lane, right-turn lane, or left-turn lane. Auxiliary lanes shall not be for through traffic use.

**Average Daily Flow (ADF)** – The arithmetic average of all daily flow determinations taken within a period of 24 consecutive hours.

**Average Daily Traffic (ADT)** – A volume that represents the total two-way traffic on a roadway for a period less than a year, divided by the total number of days it represents, and includes both weekday and weekend traffic. ADT is typically adjusted for day of the week, seasonal variations, and/or vehicle classification.

**Base Flood** – The flood event having a one percent chance of being equaled or exceeded in any given year based on existing watershed conditions, FEMA guidelines, and SFHA as shown in the current effective FIS and FIRM. Differs from design flood. The resulting water surface elevation from the base flood shall correspond with the FEMA BFE.

**Best Management Practice (BMP)** – A physical, chemical, structural, or managerial practice or device that prevents, reduces, or treats contamination of stormwater, prevents or reduces soil

erosion, and/or reduces or minimizes stormwater runoff. A BMP may be temporary to protect during construction or permanent to protect from long-term impacts of the development.

**Carrier Pipe** – A pipe used to carry stormwater, water, or wastewater, as opposed to an exterior protective casing pipe.

**Casing Pipe** – An exterior protective pipe that encases a carrier pipe for various types of crossings, including roadways, creeks, and railroads. Also known as encasement pipe.

**Collector Street** – Roadway designed to collect and distribute local traffic to and from arterial streets and provides access to adjacent properties.

**Commercial Driveway** – Provides access to office, retail, institutional, or a multiple-family building having more than 5 dwelling units. Industrial plant driveways which serve administrative or employee parking lots shall be considered commercial driveways.

**Connection** – The point at which a facility is provided service by the City water or wastewater system.

**Corner Clip** – Right-of-way dedication at intersection corners to provide sufficient room for intersection visibility, pedestrian access, and other street facilities.

**Crown** – (a) The highest point on the inside of a closed conduit; (b) The highest point of a roadway cross section. Also known as soffit.

**Deceleration Lane** – A speed-change lane, including tapered areas, which enables a vehicle exiting a roadway to leave the travel lanes and slow before making a turn.

**Depression Storage** – Collection and storage of rainfall in natural depressions or puddles after exceeding the infiltration capacity of the soil.

**Design Flood** – The flood event that is used as the basis for design to provide a stated degree of protection or other specified result. The design flood for the City of McKinney is the frequency flood specified in **Table 4-3** based on fully developed watershed conditions. Also known as design storm. Differs from base flood. The City of McKinney design flood elevation will not necessarily correspond with the FEMA BFE.

**Design Speed** – A selected speed used to determine the various geometric design features of the roadway.

**Dimension Ratio (DR)** – For pressure flow applications, the outside pipe diameter divided by the pipe wall minimum thickness. The DR provides a method of specifying product dimensions to maintain mechanical properties regardless of size. For a given dimension ratio the pipe stiffness remains constant for all pipe sizes.

**Director of Engineering** – The Director of Engineering, City Engineer, or his/her designee.

**Distribution System** – A system of pipes that conveys potable water from a water treatment plant to consumers. Distribution systems include pump stations, ground and elevated storage tanks, potable water mains, potable water service lines, and all associated valves, fittings, and meters, but excludes potable water customer service lines.

**Drainage System** – Includes streets, alleys, storm drains, drainage channels, culverts, bridges, overflow swales, and any other facility through which or over which stormwater flows.

**Engineer of Record** – The Professional Engineer (P.E.) licensed in the State of Texas through the Texas Board of Professional Engineers (TPBE) who is responsible for the signing and sealing of construction plans, studies, calculations, and/or any other engineering documents in accordance with TPBE’s requirements for professional practice. Also known as engineer.

**Firm Pumping Capacity** – The pumping capacity of the station handling the expected peak flow or the maximum hourly demand with the largest pump out of service.

**Flood Control** – The elimination or reduction of stormwater damage by means of land use restrictions, detention storage, erosion control, drainage systems, channel improvements, dikes and levees, bypass channels, and/or other engineering works. Also known as stormwater management.

**Floodplain** – The entire geographic area subject to flooding based on the design flood or base flood. The floodplain shall refer to the area subject to flooding resulting from the 100-year design flood (based on fully developed watershed conditions). The FEMA floodplain shall refer to the area subject to flooding resulting from the 100-year base flood (based on existing watershed conditions).

**Floodplain Administrator** – The City official or his/her designee appointed to administer and implement the provisions of the Stormwater Management Ordinance and other appropriate sections of 44 CFR (Emergency Management and Assistance – NFIP Regulations) pertaining to floodplain management.

**Floodplain Fringe** – Part of the SFHA within the FEMA Floodplain but outside of the Regulatory Floodway.

**Floodplain Reclamation** – The act of removing property from floodplain by the placement of fill or other topographical alteration such that the area is elevated above the base flood or design flood elevation. This does not include the elevation of a structure within the floodplain.

**Floodway** – The channel of a watercourse and the adjacent land areas that must be reserved in order to discharge the base flood without cumulatively increasing the water surface elevation by more than a designated height. Also known as regulatory floodway.

**Flowline** – The floor, bottom, or lowest elevation of an open channel or closed conduit. Also known as invert.

**Freeboard** – The distance between the design flood elevation and the top of an open channel, dam, levee, or detention basin to allow for wave action, floating debris, or any other condition or emergency without overflowing the structure.

**Frontage Road** – A local roadway along an arterial highway allowing control of access and service to adjacent areas and property. Also known as a service road.

**Fully Developed** – The condition of the watershed after the entire watershed has undergone development. Refer to the current City of McKinney Future Land Use Plan to determine future land uses. Also known as ultimate development.

**Greenbelt Spine Trail** – A trail with a typical width of 12 feet connecting parks found along the creek corridors. Greenbelt Spine Trails have the highest level of amenities where users experience little to no interaction with motor vehicle traffic. Where Greenbelt Spine Trails cross streets, crossings are either fully grade-separated or have signalized traffic control to increase safety and visibility.

**Improved Channel** – A drainage channel or area of concentrated drainage that has been cleared, excavated, realigned, lined, graded, stabilized, or created by equipment. Also known as improved creek and improved stream.

**Industrial Driveway** – Serves truck movements to and from loading areas of industrial, warehouse, or truck terminals. A community or regional shopping center may have one or more driveways specially designed, signed, and located to provide access for trucks.

**Intersection** – Any at grade connection with a roadway. This includes the connection of two roadways or a driveway and a roadway.

**Level of Service (LOS)** – A measure of traffic flow and congestion. LOS is a qualitative measure describing operational conditions within a traffic stream, generally described in terms of speed, travel time, freedom to maneuver, traffic interruptions, comfort, convenience, and safety.

**Local Street** – A minor roadway that serves abutting land use and traffic within a neighborhood or limited residential area.

**Maximum Daily Demand** – The total amount of water used during the day of heaviest consumption in any given year and the minimum rate, which the high service pumps shall be capable of pumping. Water shall be supplied to the pumps at this rate.

**Maximum Hourly Demand** – The rate at which water is drawn from the entire system during the hour of maximum consumption on the day of maximum demand. This rate is generally of a short duration and is most economically provided for by the use of elevated storage in addition to water supplied to the system by pumps. The distribution system, including storage and pumping capacity, shall be able to satisfy this demand. Also known as peak flow.

**Median** – The portion of a divided roadway separating the opposing traffic flows. A median may be traversable or non-traversable.

**Median Opening** – An opening in a non-traversable median that allows accessing or crossing the opposing traffic lanes.

**Minimum Hourly Demand** – This is the rate at which water is drawn from the distribution system during the hour of minimum demand on the day of maximum demand. This rate is used in the water distribution analysis to determine the adequacies of the system to replenish elevated storage.

**Natural Channel** – An unlined and unimproved existing drainage channel that has not been graded, modified, cleared, or created by equipment. Also known as natural creek and natural stream.



**Non-traversable Median** – A physical barrier in a roadway or driveway that separates vehicular traffic traveling in opposite directions, and prohibits movement of traffic across the median. Non-traversable medians include, but are not limited to, concrete barriers, raised concrete curbs and/or islands, and grass or swale medians.

**Owner** – For the purposes of this manual, owner refers to the person responsible for developing a particular site or project. Also referred to as developer.

**Parkway** – (a) An area within the right-of-way but outside the edge of pavement which is typically reserved for public use other than vehicular traffic; (b) a freeway which does not have continuous frontage roads.

**Post-development** – The condition of the given site and drainage area after the anticipated development has taken place. Also known as post-project.

**Pre-development** – The existing condition of the given site and drainage area prior to development. Also known as pre-project.

**Residential Driveway** – Provides access to a single family residence, a duplex, or a multi-family building containing three or fewer dwelling units. These drives shall intersect primarily residential streets or collector streets. All access to residential property abutting all other thoroughfares shall be off an alley or a service road.

**Right-of-Way (ROW)** – A strip of land dedicated for use of public streets and/or related facilities. Other facilities include, but are not limited to, utilities, drainage systems, and other transportation uses.

**ROW Width** – The shortest horizontal distance between the lines which delineate the limits of right-of-way.

**Sidewalk** – A paved area within the right-of-way specifically designed for pedestrians and/or bicyclists.

**Sight Distance** – The distance visible to the driver of a passenger vehicle measured along the normal travel path of a roadway from a designated location and to a specified height above the roadway when the view is unobstructed by traffic.

**Standard Dimension Ratio (SDR)** – For gravity flow applications, the pipe diameter divided by the pipe wall thickness and provides a method of specifying product dimensions to maintain mechanical properties regardless of size. For a given dimension ratio the pipe stiffness remains constant for all pipe sizes.

**Standard of Care** – The care and skill ordinarily used by members of the subject profession practicing under similar circumstances at the same time and in the same locality. No provision or requirement of the Engineering Design Manual shall relieve the engineer of his/her responsibility to meet the standards of conduct and ethics established by the Texas Board of Professional Engineers (TPBE).



**Stopping Sight Distance (SSD)** – The distance required by a driver of a vehicle, traveling at a given speed, to bring the vehicle to a stop after an object on the roadway becomes visible. It includes the distance traveled during driver perception time, reaction time, and the vehicle braking distance.

**Storage Length** – The portion of an auxiliary lane required to store the number of vehicles expected to accumulate in the lane during an average peak period.

**Time of Concentration** – The estimated time required for runoff to flow from the most hydraulically remote section of the drainage area to the point at which the flow is to be determined. Hydraulically remote refers to the travel path with the longest flow travel time, not necessarily the longest linear distance.

**Trunk Line** – The main line of a storm drain system. This includes lines extending from manhole to manhole or from manhole to outlet structure.

**Unified Development Code** - The Unified Development Code adopted by the City of McKinney, including any subsequent amendments, or any predecessor ordinance (zoning, subdivision, stormwater, etc.) that may remain applicable via vested rights.

**Watershed** – The area contributing stormwater runoff to a stream or drainage system. Also known as drainage area, drainage basin, and catchment area.

## **ABBREVIATIONS**

% – Percent.

' – Foot or feet.

" – Inch or inches.

**AASHTO** – American Association of State Highway and Transportation Officials.

**ACI** – American Concrete Institute.

**ADA** – Americans with Disabilities Act.

**ADT** – Average Daily Traffic.

**AMC** – Antecedent Moisture Condition.

**amp** – Ampere.

**ANSI** – American National Standards Institute.

**ASCE** – American Society of Civil Engineers.

**ASME** – American Society of Mechanical Engineers.

**ASTM** – American Society for Testing and Materials.

**ATSSA** – American Traffic Safety Services Association.

**AWWA** – American Water Works Association.

**AVG** – Average.

**b-b** – Back of curb to back of curb distance.

**BC** – Barricade and Construction.

**BFE** – Base Flood Elevation.

**BMP** – Best Management Practice.

**CAD** – Computer-aided Design.

**CFR** – Code of Federal Regulations.  
**cfs** – Cubic feet per second.  
**CGP** – Construction General Permit.  
**CLOMR** – Conditional Letter of Map Revision.  
**CPS** – Corrosion Protection System.  
**CSN** – Construction Site Notice.  
**CWA** – Clean Water Act.  
**DIPS** – Ductile Iron Pipe Standard.  
**ECP** – Erosion Control Plan.  
**EGL** – Energy grade line.  
**EPA** – Environmental Protection Agency.  
**ETJ** – Extraterritorial Jurisdiction.  
**FAA** – Federal Aviation Administration.  
**FDC** – Fire Department Connection.  
**FEMA** – Federal Emergency Management Agency.  
**f-f** – Curb face to curb face distance.  
**FHBM** – Flood Hazard Boundary Map.  
**FHWA** – Federal Highway Administration.  
**FIRM** – Federal Insurance Rate Map.  
**FIS** – Flood Insurance Study.  
**FM** – Farm to Market road.  
**fps** – Feet per second.  
**FRP** – Fiberglass reinforced pipe.  
**gpad** – Gallons per acre per day.  
**gpcd** – Gallons per capita per day.  
**gpd** – Gallons per day.  
**gpm** – Gallons per minute.  
**GPS** – Global Positioning System.  
**H** – Horizontal.  
**HEC-HMS** – Hydrologic Engineering Center Hydrologic Modeling System.  
**HEC-RAS** - Hydrologic Engineering Center River Analysis System.  
**HDPE** – High Density Polyethylene.  
**HGL** – Hydraulic grade line.  
**HOA** – Homeowners Association.  
**H-O-A** – Hand-Off-Auto.  
**IFC** – International Fire Code.  
**IMSA** – International Municipal Signal Association.  
**in** – Inch.  
**IRF** – Intruder resistant fence.  
**ISD** – Independent School District.  
**iSWM** – Integrated Stormwater Management.  
**ITE** – Institute of Transportation Engineers.  
**KVA** – Thousand volt-amperes.  
**L** – Liter.  
**lbs** – Pound or pounds.

**LF** – Linear Feet.  
**LIDAR** – Light Detection and Ranging.  
**LOMA** – Letter of Map Amendment.  
**LOMR** – Letter of Map Revision.  
**LOS** – Level of Service.  
**Max** – Maximum.  
**mg** – Milligram.  
**mgd** – Million gallons per day.  
**mg/L** – Milligram per Liter.  
**Min** – Minimum.  
**mph** – Miles per hour.  
**MSE** – Mechanically Stabilized Earth.  
**msl** – Mean seal level.  
**MSMTR** – Multi-Stream, Multi-Trajectory, Rotating.  
**MS4** – Municipal Separate Storm Sewer System.  
**MTC** – McKinney Town Center.  
**NCHRP** – National Cooperative Highway Research Program.  
**NCTCOG** – North Central Texas Council of Governments.  
**NEC** – National Electric Code.  
**NEPA** – National Environmental Policy Act.  
**NFIP** – National Flood Insurance Program.  
**NFPA** – National Fire Protection Association.  
**NOI** – Notice of Intent.  
**NOT** – Notice of Termination.  
**NPDES** – National Pollution Discharge Elimination System.  
**NRCS** – National Resources Conservation Service.  
**NRHP** – National Registration of Historic Places.  
**NST** – National Standard Thread.  
**NTMWD** – North Texas Municipal Water District.  
**NTTA** – North Texas Tollway Authority.  
**OHWM** – Ordinary High Water Mark.  
**OSHA** – Occupational Safety and Health Administration.  
**PC** – Point of curvature.  
**PCM** – Protective coating material.  
**PCSQP** – Post Construction Stormwater Quality Plan.  
**P.E.** – Professional Engineer.  
**PHT** – Peak hour trip.  
**PI** – Plasticity Index.  
**PI** – Point of intersection.  
**PMF** – Probable Maximum Flood.  
**PMP** – Probable Maximum Precipitation.  
**PN** – Pressure Class Number.  
**ppm** – Parts per million.  
**PROWAG** – Proposed Accessibility Guidelines for Pedestrian Facilities in the Public Right-of-Way.

**psi** – Pounds per square inch.  
**PT** – Point of tangency.  
**PD** – Planned Development.  
**PVC** – Polyvinyl Chloride.  
**PVI** – Point of Vertical Intersection.  
**PVR** – Potential Vertical Rise.  
**QL** – Utility Quality Level.  
**RA** – Residential Alley.  
**RCP** – Reinforced concrete pipe.  
**REV** – Revision.  
**ROW** – Right-of-Way.  
**RQ** – Reportable quantity.  
**RTP** – Regional Transportation Plan.  
**RTU** – Remote terminal unit.  
**RWGV** – Resilient Wedge Gate Valve.  
**S** – Sight Distance.  
**SCADA** – Supervisory Control and Data Acquisition.  
**SCS** – Soil Conservation Service.  
**SDF** – Spillway Design Flood.  
**SDR** – Standard Dimension Ratio.  
**SFHA** – Special Flood Hazard Area.  
**SH** – State Highway.  
**SN** – Structural Number.  
**SPF** – Standard Project Flood.  
**SPP** – Standard Project Precipitation.  
**SSD** – Stopping Sight Distance.  
**SUE** – Subsurface Utility Engineering.  
**SW3P** – Stormwater Pollution Prevention Plan.  
**s/veh** – Seconds per vehicle.  
**TAC** – Texas Administrative Code.  
**TAS** – Texas Accessibility Standards.  
**TBPE** – Texas Board of Professional Engineers.  
**T<sub>c</sub>** – Time of Concentration.  
**TCEQ** – Texas Commission on Environmental Quality.  
**TCP** – Traffic Control Plan.  
**TDLR** – Texas Department of Licensing and Regulation.  
**THC** – Texas Historical Commission.  
**TIA** – Traffic Impact Analysis.  
**TMUTCD** – Texas Manual on Uniform Traffic Control Devices.  
**tpd** – Trips per day.  
**TPDES** – Texas Pollution Discharge Elimination System.  
**TPWD** – Texas Parks & Wildlife Department.  
**TWDB** – Texas Water Development Board.  
**TxDOT** – Texas Department of Transportation.  
**U.S.** – United States.

**USACE** – United States Army Corps of Engineers.

**USFWS** – United States Fish and Wildlife Service.

**USGS** – United States Geological Survey.

**V** – Vertical or Velocity (depending on context).

**VPD** – Vehicles Per Day.

**WZ** – Work Zone.

**APPENDIX B**

**CITY CHECKLISTS**

## **CITY CHECKLISTS**

1. Geotechnical Report for Roadways Checklist
2. Summary of Geotechnical Recommendations Form
3. Bridge Construction Inspection and Certification Checklist
4. Post Construction Stormwater Quality Plan Checklist
5. Land Acquisition Submittal Checklist
6. [Civil Engineering Plan Submittal Process](#)
7. [Civil Engineering Development Plan Review Checklist](#)
8. [Tree Permit Requirements Checklist](#)
9. [Engineering Development Final Acceptance Checklist](#)

The engineer shall verify the current edition of the checklists with the Engineering Department.

## Geotechnical Report for Roadways Checklist

Project Name: \_\_\_\_\_

Geotechnical Engineer/Firm: \_\_\_\_\_

Report Date: \_\_\_\_\_

Date Received: \_\_\_\_\_

*Note: Any N/A response shall include a written explanation with adequate justification, as deemed necessary by the Director of Engineering.*

COMPLETE	N/A	1. SECTION 3.1 GENERAL
<input type="checkbox"/>	<input type="checkbox"/>	A. Include the <i>Summary of Geotechnical Recommendations Form</i>
<input type="checkbox"/>	<input type="checkbox"/>	B. Description of Project
<input type="checkbox"/>	<input type="checkbox"/>	C. Location of Project
<input type="checkbox"/>	<input type="checkbox"/>	D. Roadway type and classification
<input type="checkbox"/>	<input type="checkbox"/>	E. Grading plan and summary
<input type="checkbox"/>	<input type="checkbox"/>	F. Discussion of underground utilities within the Project limits
COMPLETE	N/A	2. SECTION 3.2 EXISTING SURFACE/SUBSURFACE INVESTIGATION
<input type="checkbox"/>	<input type="checkbox"/>	A. Discussion of existing surface/subsurface conditions that may affect subgrade and pavement design or performance (i.e. vegetation, terrain, existing structures, existing pavement, etc.)
<input type="checkbox"/>	<input type="checkbox"/>	B. Discussion of geological conditions that may impact subgrade and pavement design or performance. Specify formation.
<input type="checkbox"/>	<input type="checkbox"/>	C. Surface/subsurface conditions with logs <ul style="list-style-type: none"> <li>- Sampling techniques</li> <li>- Description of soil and rock encountered, including lab test details</li> <li>- Discussion of water and groundwater conditions</li> <li>- Discussion of seasonal variations in moisture content</li> <li>- Atterberg limits (ASTM D 4318)</li> <li>- Percent Passing the No. 200 sieve (ASTM D 1140)</li> </ul>
<input type="checkbox"/>	<input type="checkbox"/>	D. All standards used in field and laboratory testing shall be identified. Any deviations to standard procedures shall be discussed.
COMPLETE	N/A	3. SECTION 3.3 SUBSURFACE DESIGN
<input type="checkbox"/>	<input type="checkbox"/>	A. Expansive Soils Evaluation <ul style="list-style-type: none"> <li>- Percent swell calculation and test results</li> <li>- Effect of cut/fills (i.e. long-term soil uplift in cut areas; settlement overburden pressure effects in fill areas)</li> <li>- Identify soil movement estimates at each boring location</li> <li>- Explanation of anomalous variations within the soil profile and between borings (i.e., Atterberg limits, PI, sulfates, clay to rock, etc.)</li> </ul>
<input type="checkbox"/>	<input type="checkbox"/>	B. Soil Moisture Conditioning <ul style="list-style-type: none"> <li>- Discussion of swell test results summary</li> <li>- Recommended depth of moisture conditioning</li> <li>- Address transition between zones of varying depth</li> <li>- Discussion of possible variations during construction and mitigation thereof</li> <li>- Discussion of techniques to maintain moisture in soil</li> </ul>



## Geotechnical Report for Roadways Checklist

- Discussion of methods to test soil moisture conditioning during construction (i.e. a second geotechnical investigation/re-evaluation may be required to specifically address soil moisture prior to lime operations)
- Address street trees

<b>COMPLETE</b>	<b>N/A</b>	<b>4. SECTION 3.4 SUBGRADE DESIGN</b>
<input type="checkbox"/>	<input type="checkbox"/>	<b>A. Subgrade Stabilization</b> <ul style="list-style-type: none"> <li>- Typical subgrade type</li> <li>- Explanation of anomalous soil conditions anticipated and discussion of potential variations to consider</li> <li>- Construction techniques to implement</li> <li>- Effects of rock/rock fragments encountered during construction and recommendations to abate</li> </ul>
<input type="checkbox"/>	<input type="checkbox"/>	<b>B. Soluble Sulfates</b> <ul style="list-style-type: none"> <li>- Identify soluble sulfate test results; summarize results and discuss variations</li> <li>- Discussion of techniques during construction to mitigate sulfate-induced heaving</li> <li>- Sulfate retesting during construction</li> </ul>
<b>COMPLETE</b>	<b>N/A</b>	<b>5. SECTION 3.5 PAVEMENT DESIGN</b>
<input type="checkbox"/>	<input type="checkbox"/>	<b>A. Identify roadway type(s) and classifications(s)</b>
<input type="checkbox"/>	<input type="checkbox"/>	<b>B. Identify deviations from Pavement Design Input Values (Re: <b>Table 3-2</b>)</b>
<input type="checkbox"/>	<input type="checkbox"/>	<b>C. Identify recommended pavement section</b>
<b>COMPLETE</b>	<b>N/A</b>	<b>6. APPENDIX</b>
<input type="checkbox"/>	<input type="checkbox"/>	<b>A. Geological Map</b>
<input type="checkbox"/>	<input type="checkbox"/>	<b>B. Boring Locations</b>
<input type="checkbox"/>	<input type="checkbox"/>	<b>C. Boring Logs</b>
<input type="checkbox"/>	<input type="checkbox"/>	<b>D. Grading Plan (for non-linear projects)</b>
<input type="checkbox"/>	<input type="checkbox"/>	<b>E. Cut vs. fill by station number (for linear projects)</b>
<input type="checkbox"/>	<input type="checkbox"/>	<b>F. Printout from WinPAS pavement design software program</b>
<input type="checkbox"/>	<input type="checkbox"/>	<b>G. Proposed typical section with dimensions showing pavement thickness, subgrade type and thickness, moisture conditioning depth, and location of moisture barrier. If applicable, location of proposed trees and root barriers shall be shown.</b>

**Geotechnical Engineer Signature:** \_\_\_\_\_

**Date:** \_\_\_\_\_



## Summary of Geotechnical Recommendations Form

Project Name: \_\_\_\_\_

Geotechnical Engineer/Firm: \_\_\_\_\_

Report Date: \_\_\_\_\_

Date Received: \_\_\_\_\_

*Geotechnical Engineer must fill out this form completely, and submit with the Report. A proposed typical section detail must be provided.*

### 1. DESIGN INPUT VALUES:

Thoroughfare Classification(s): \_\_\_\_\_

Formation: \_\_\_\_\_

PI Range: \_\_\_\_\_

Pavement Design Input Value Deviation(s): \_\_\_\_\_

### 2. DESIGN RECOMMENDATIONS:

Moisture Conditioning Depth (inches): \_\_\_\_\_ *If yes, include plan layout depicting limits*

Lime Thickness (inches): \_\_\_\_\_

Lime Application Rate (calculated): \_\_\_\_\_ + 1% = \_\_\_\_\_  
*lab value minimum required*

Lime Application Rate (design value): \_\_\_\_\_

Alternate Subgrade (Y/N): \_\_\_\_\_ *If yes, describe*

Sulfates over 6,000 ppm (Y/N): \_\_\_\_\_ *If yes, double lime application required*

Concrete Thickness (inches): \_\_\_\_\_

### Miscellaneous Items and Notes:

\_\_\_\_\_  
\_\_\_\_\_  
\_\_\_\_\_  
\_\_\_\_\_  
\_\_\_\_\_

Geotechnical Engineer Signature: \_\_\_\_\_

Date: \_\_\_\_\_



## Bridge Construction Inspection and Certification Checklist

Project Name: \_\_\_\_\_

Inspector Name: \_\_\_\_\_

Design Engineer: \_\_\_\_\_

Report Date: \_\_\_\_\_

*Inspector shall certify bridge construction inspections were performed at the prescribed stages of construction in accordance with the following checklist. The inspection reports and final certificate of compliance shall be submitted to the City and include the following items.*

COMPLETE	N/A	1. BEFORE CONCRETE PLACEMENT
<input type="checkbox"/>	<input type="checkbox"/>	A. Check beam profiles after they are erected to see if vertical profile adjustment is necessary.
<input type="checkbox"/>	<input type="checkbox"/>	B. Check to ensure contractor's profile of slab includes the anticipated dead load deflection values.
<input type="checkbox"/>	<input type="checkbox"/>	C. Check that safety measures are in-place according to OSHA standards, toe-board, rail, etc. throughout duration.
<input type="checkbox"/>	<input type="checkbox"/>	D. Check that maximum build up of panel shims are not exceeded. Verify that panels overhang the shims, so that panel is supported by concrete and not shims throughout the design life.
<input type="checkbox"/>	<input type="checkbox"/>	E. Check that thickened ends (cast-in-place diaphragms) of spans are per plan dimensions.
<input type="checkbox"/>	<input type="checkbox"/>	F. Check reinforcing steel. Epoxy coated? If epoxy coated specified, chairs and tie wire must also be epoxy coated. Size? Spacing? Grade? Percent tied? Percent supported? Is steel from an approved source?
<input type="checkbox"/>	<input type="checkbox"/>	G. Check that longitudinal splicing of reinforcing steel is staggered.
<input type="checkbox"/>	<input type="checkbox"/>	H. Check, if applicable, steel for bridge rail (anchor steel). Spacing? Grading? Location of joints? Drainage openings (slots)?
<input type="checkbox"/>	<input type="checkbox"/>	I. Check that overhang brackets are according to pre-approved forming detail.
<input type="checkbox"/>	<input type="checkbox"/>	J. Check screed during dry run – Vibrator's amplification; Rotation of steel drums; are they true? When drum reaches ends, must have smooth change in direction, not a jump that will indent fresh concrete. Check drum at armor joints.
<input type="checkbox"/>	<input type="checkbox"/>	K. Check slab depth and reinforcing steel coverage from bottom of steel drums during screed dry run at quarter points on regular intervals.
<input type="checkbox"/>	<input type="checkbox"/>	L. Check that contractor has a water mister.
<input type="checkbox"/>	<input type="checkbox"/>	M. Hold a pre-concrete placement field meeting prior to scheduled placement.
<input type="checkbox"/>	<input type="checkbox"/>	N. Check contractor's slab concrete mix design. Does it meet specifications? Has it been approved? Have material tests and admixture certifications on file before concrete placement.



## Bridge Construction Inspection and Certification Checklist

<b>COMPLETE</b>	<b>N/A</b>	<b>2. DURING CONCRETE PLACEMENT</b>
<input type="checkbox"/>	<input type="checkbox"/>	A. Check that materials testing lab is onsite and prepared.
<input type="checkbox"/>	<input type="checkbox"/>	B. Check that contractor has enough polyethylene to cover slab in case of unexpected rain.
<input type="checkbox"/>	<input type="checkbox"/>	C. Check, if applicable, contractor has all cold weather equipment necessary and onsite prior to beginning pour to maintain minimum concrete temperature, including proper high-low thermometers. In hot weather, ensure contractor has measures in place to maintain concrete temperatures (ice, etc.).
<input type="checkbox"/>	<input type="checkbox"/>	D. Check that contractor has all the necessary material onsite prior to beginning pour to water cure the concrete slab for the duration specified.
<input type="checkbox"/>	<input type="checkbox"/>	E. Check that contractor's personnel have the proper safety equipment.
<input type="checkbox"/>	<input type="checkbox"/>	F. Check that curing compound is being applied to the slab properly.
<input type="checkbox"/>	<input type="checkbox"/>	G. Check that measured depth of placed concrete slab meets design requirements.
<input type="checkbox"/>	<input type="checkbox"/>	H. Check to see if contractor needs wrecking cylinders.
<input type="checkbox"/>	<input type="checkbox"/>	I. Check concrete truck tickets and confirm that approved concrete mix design is used.
<input type="checkbox"/>	<input type="checkbox"/>	J. Check that contractor does not exceed "water withheld amount" if water is being added after truck arrives.
<input type="checkbox"/>	<input type="checkbox"/>	K. Check and run all concrete tests on first truck, slump, air, make cylinders and temperature. After this, perform air and slump tests if needed to ensure concrete compliance.
<input type="checkbox"/>	<input type="checkbox"/>	L. Check concrete temperature regularly. Reject loads that are out of temperature specifications.
<input type="checkbox"/>	<input type="checkbox"/>	M. Check that slab is being straight edged at 45 degrees direction from both sides in addition to the roller screed.
<input type="checkbox"/>	<input type="checkbox"/>	N. Check that concrete is not too wet or dry when contractor begins carpet dragging/brooming and tining (if allowed).
<input type="checkbox"/>	<input type="checkbox"/>	O. Check that contractor's surveyors are taking overhang shots to ensure the anticipated dead load deflection. Must make immediate adjustments if needed. Visually inspect overhangs for irregularities.
<b>3. AFTER CONCRETE PLACEMENT</b>		
<input type="checkbox"/>	<input type="checkbox"/>	A. Check that quality control test cylinders are removed from the field as specified.
<input type="checkbox"/>	<input type="checkbox"/>	B. Check that wrecking cylinders are being cured same way as slab.
<input type="checkbox"/>	<input type="checkbox"/>	C. Check, if applicable, that cold weather requirements are being met.
<input type="checkbox"/>	<input type="checkbox"/>	D. Check that slab is being water cured properly throughout the required duration.

**Inspector Signature:** \_\_\_\_\_

**Date:** \_\_\_\_\_



## Post Construction Stormwater Quality Plan Checklist

Project Name: \_\_\_\_\_

Engineer of Record: \_\_\_\_\_

Firm: \_\_\_\_\_

Impervious Surface (acres): \_\_\_\_\_ DEV#: \_\_\_\_\_

Site Size (acres): \_\_\_\_\_ Number of Permanent BMPs: \_\_\_\_\_

Report Date: \_\_\_\_\_ Date Received: \_\_\_\_\_

*Engineer of Record must fill out this form completely and submit with additional items in accordance with the Civil Engineering Plan Review Development checklist.*

Physical Address: \_\_\_\_\_

Property Owner: \_\_\_\_\_

Property Owner Mailing Address: \_\_\_\_\_

Property Owner Telephone Number: (\_\_\_\_\_) \_\_\_\_\_

Responsible Party for Maintenance: \_\_\_\_\_

**COMPLETE**

**N/A**

**1. Are the following existing site features shown?**

A. Existing two foot contours

B. Existing drainage patterns and features

C. Existing "C" value (runoff coefficient)

D. "Q" for 2-year, 24-hour duration storm event (pre-development)

E. Approximate limit of tree canopy

F. Tree survey, if commercial site

G. Approximate limit of wetlands

H. Soil type and classification

I. Fully Developed 100-year floodplain and FEMA 100-year floodplain delineated

## Post Construction Stormwater Quality Plan Checklist

COMPLETE	N/A	
<input type="checkbox"/>	<input type="checkbox"/>	<b>2. Are the following permanent, <u>post-development</u> site features shown?</b>
<input type="checkbox"/>	<input type="checkbox"/>	A. Total site impervious area (square feet) for Commercial Projects
<input type="checkbox"/>	<input type="checkbox"/>	B. Total site open space area (acres) for Residential Projects
<input type="checkbox"/>	<input type="checkbox"/>	C. Proposed two foot contours
<input type="checkbox"/>	<input type="checkbox"/>	D. Drainage areas and sub areas delineated and labeled
<input type="checkbox"/>	<input type="checkbox"/>	E. Proposed stormwater conveyance systems
<input type="checkbox"/>	<input type="checkbox"/>	F. Flow arrows for surface drainage
<input type="checkbox"/>	<input type="checkbox"/>	G. Post-development "C" value (runoff coefficient)
<input type="checkbox"/>	<input type="checkbox"/>	H. "Q" for 2-year, 24-hour duration storm event (post-development)
<input type="checkbox"/>	<input type="checkbox"/>	I. Site layout
<input type="checkbox"/>	<input type="checkbox"/>	J. Areas to be protected from disturbance
<input type="checkbox"/>	<input type="checkbox"/>	K. Trees to be saved
<input type="checkbox"/>	<input type="checkbox"/>	L. Fully Developed 100-year floodplain and FEMA 100-year floodplain delineated
<input type="checkbox"/>	<input type="checkbox"/>	M. Erosion Hazard Setback and drainage easements
<input type="checkbox"/>	<input type="checkbox"/>	N. List of potential pollutants
<input type="checkbox"/>	<input type="checkbox"/>	O. Proposed Permanent BMPs

**Label for Record Plat:**

Post-Construction BMPs maintenance requirements

1. Bioretention Area-maintenance as listed in iSWM revision 2014
2. Enhanced Swale-maintenance as listed iSWM Revised 2014

Responsible party of post-construction maintenance is XXXXXXXX – Owner of Property



## Post Construction Stormwater Quality Plan Checklist

### Post Construction Maintenance Plan

#### Permanent BMP #1

Description: \_\_\_\_\_  
\_\_\_\_\_  
\_\_\_\_\_

Maintenance: \_\_\_\_\_  
\_\_\_\_\_

Responsible Party for Maintenance: \_\_\_\_\_  
\_\_\_\_\_

COMPLETE	N/A	
<input type="checkbox"/>	<input type="checkbox"/>	1. Design criteria provided
<input type="checkbox"/>	<input type="checkbox"/>	2. Appropriate application
<input type="checkbox"/>	<input type="checkbox"/>	3. Shown as public or private
<input type="checkbox"/>	<input type="checkbox"/>	4. Coordinated with drainage plan
<input type="checkbox"/>	<input type="checkbox"/>	5. Coordinated with landscaping plan

#### Permanent BMP #2

Description: \_\_\_\_\_  
\_\_\_\_\_  
\_\_\_\_\_

Maintenance: \_\_\_\_\_  
\_\_\_\_\_

Responsible Party for Maintenance: \_\_\_\_\_  
\_\_\_\_\_

COMPLETE	N/A	
<input type="checkbox"/>	<input type="checkbox"/>	1. Design criteria provided
<input type="checkbox"/>	<input type="checkbox"/>	2. Appropriate application
<input type="checkbox"/>	<input type="checkbox"/>	3. Shown as public or private
<input type="checkbox"/>	<input type="checkbox"/>	4. Coordinated with drainage plan
<input type="checkbox"/>	<input type="checkbox"/>	5. Coordinated with landscaping plan



Post Construction Maintenance Plan

Permanent BMP #3

Description: \_\_\_\_\_  
\_\_\_\_\_  
\_\_\_\_\_

Maintenance: \_\_\_\_\_

Responsible Party for Maintenance: \_\_\_\_\_

COMPLETE	N/A	
<input type="checkbox"/>	<input type="checkbox"/>	1. Design criteria provided
<input type="checkbox"/>	<input type="checkbox"/>	2. Appropriate application
<input type="checkbox"/>	<input type="checkbox"/>	3. Shown as public or private
<input type="checkbox"/>	<input type="checkbox"/>	4. Coordinated with drainage plan
<input type="checkbox"/>	<input type="checkbox"/>	5. Coordinated with landscaping plan

Permanent BMP #4

Description: \_\_\_\_\_  
\_\_\_\_\_  
\_\_\_\_\_

Maintenance: \_\_\_\_\_

Responsible Party for Maintenance: \_\_\_\_\_

COMPLETE	N/A	
<input type="checkbox"/>	<input type="checkbox"/>	1. Design criteria provided
<input type="checkbox"/>	<input type="checkbox"/>	2. Appropriate application
<input type="checkbox"/>	<input type="checkbox"/>	3. Shown as public or private
<input type="checkbox"/>	<input type="checkbox"/>	4. Coordinated with drainage plan
<input type="checkbox"/>	<input type="checkbox"/>	5. Coordinated with landscaping plan





## Post Construction Stormwater Quality Plan Checklist

### Post Construction Maintenance Plan

**Permanent BMP #5**

Description: \_\_\_\_\_  
\_\_\_\_\_  
\_\_\_\_\_

Maintenance: \_\_\_\_\_  
\_\_\_\_\_

Responsible Party for Maintenance: \_\_\_\_\_  
\_\_\_\_\_

COMPLETE	N/A	
<input type="checkbox"/>	<input type="checkbox"/>	1. Design criteria provided
<input type="checkbox"/>	<input type="checkbox"/>	2. Appropriate application
<input type="checkbox"/>	<input type="checkbox"/>	3. Shown as public or private
<input type="checkbox"/>	<input type="checkbox"/>	4. Coordinated with drainage plan
<input type="checkbox"/>	<input type="checkbox"/>	5. Coordinated with landscaping plan

**Miscellaneous Items and Notes:**

\_\_\_\_\_  
\_\_\_\_\_  
\_\_\_\_\_  
\_\_\_\_\_  
\_\_\_\_\_

Engineer of Record Signature: \_\_\_\_\_

Date: \_\_\_\_\_



## Post Construction Stormwater Quality Plan Checklist

---

### EXAMPLE

Project Name: Example 1

Engineer of Record: Bob Bobson

Firm: Bob's Engineering

Impervious Surface (acres): 5.3 DEV#: DEV2019-0000

Site Size (acres): 43 Number of Permanent BMPs: 2

Report Date: 12-1-2019 Date Received: 12-5-2019

*Engineer of Record must fill out this form completely and submit with additional items in accordance with the Civil Engineering Plan Review Development checklist. Attach Inspection and Maintenance Requirements to this form.*

Physical Address: 3 Oak Rd

Property Owner: Stacy Stacyson

Property Owner Mailing Address: 723 Stacy Rd, McKinney TX 75069

Property Owner Telephone Number: (222) 555-9999

Responsible Party for Maintenance: Stacy Stacyson

---

## Post Construction Stormwater Quality Plan Checklist

### EXAMPLE 1

**Permanent BMP #1** Bioretention Area- Maintenance as listed in iSWM revision 2014

Description: Bioretention area that is located in the NW corner of the site. 50ft in length collecting the drain of 2.5 acres

Maintenance:

Activity	Schedule
<ul style="list-style-type: none"> <li>• Pruning and weeding to maintain appearance.</li> <li>• Mulch replacement when erosion is evident.</li> <li>• Remove trash and debris.</li> </ul>	As needed
<ul style="list-style-type: none"> <li>• Inspect inflow points for clogging (off-line systems). Remove any sediment.</li> <li>• Inspect filter strip/grass channel for erosion or gullyng. Re-seed or sod as necessary.</li> <li>• Trees and shrubs should be inspected to evaluate their health and remove any dead or severely diseased vegetation.</li> </ul>	Semi-annually
<ul style="list-style-type: none"> <li>• The planting soils should be tested for pH to establish acidic levels. If the pH is below 5.2, limestone should be applied. If the pH is above 7.0 to 8.0, then iron sulfate plus sulfur can be added to reduce the pH.</li> </ul>	Annually
<ul style="list-style-type: none"> <li>• Replace mulch over the entire area.</li> <li>• Replace pea gravel diaphragm if warranted (or when the voids are obviously filled with sediment and water is no longer infiltrating).</li> </ul>	2 to 3 years

(Source: EPA, 1999)

**Additional Maintenance Considerations and Requirements**

The surface of the ponding area may become clogged with fine sediment over time. Core aeration or cultivating of unvegetated areas may be required to ensure adequate filtration.



Regular inspection and maintenance is critical to the effective operation of bioretention facilities as designed. Maintenance responsibility for a bioretention area should be vested with a responsible authority by means of a legally binding and enforceable maintenance agreement that is executed as a condition of plan approval.

Responsible Party for Maintenance: Owner

- | COMPLETE                            | N/A                      |                                      |
|-------------------------------------|--------------------------|--------------------------------------|
| <input checked="" type="checkbox"/> | <input type="checkbox"/> | 1. Design criteria provided          |
| <input checked="" type="checkbox"/> | <input type="checkbox"/> | 2. Appropriate application           |
| <input checked="" type="checkbox"/> | <input type="checkbox"/> | 3. Shown as public or private        |
| <input checked="" type="checkbox"/> | <input type="checkbox"/> | 4. Coordinated with drainage plan    |
| <input checked="" type="checkbox"/> | <input type="checkbox"/> | 5. Coordinated with landscaping plan |

Miscellaneous Items and Notes:

None

Engineer of Record Signature: Bob Hobson

Date: 12-1-2019


EXAMPLE 2

Permanent BMP #2 Enhanced Swale- Maintenance as listed iSWM Revised 2014

Description: Enhanced Swale that works with the Bioretention area to form a treatment train. The Enhanced Swale is 20 ft in length across the NW corner of the property.

Maintenance:

Activity	Schedule
<ul style="list-style-type: none"> <li>For dry swales, mow grass to maintain a height of 4 to 6 inches. Remove grass clippings.</li> </ul>	As needed (frequent/seasonally)
<ul style="list-style-type: none"> <li>Inspect grass along side slopes for erosion and formation of rills or gullies and correct.</li> <li>Remove trash and debris accumulated in the inflow forebay.</li> <li>Inspect and correct erosion problems in the sand/soil bed of dry swales.</li> <li>Based on inspection, plant an alternative grass species if the original grass cover has not been successfully established.</li> <li>Replant wetland species (for wet swale) if not sufficiently established.</li> <li>Inspect pea gravel diaphragm for clogging and correct the problem.</li> </ul>	Annually (Semi-annually the first year)
<ul style="list-style-type: none"> <li>Roto-till or cultivate the surface of the sand/soil bed of dry swales if the swale does not draw down within 48 hours.</li> <li>Remove sediment build-up within the bottom of the swale once it has accumulated to 25% of the original design volume.</li> </ul>	As needed

 Regular inspection and maintenance is critical to the effective operation of an enhanced swale system as designed. Maintenance responsibility for a dry or wet swale should be vested with a responsible authority by means of a legally binding and enforceable maintenance agreement that is executed as a condition of plan approval.

Responsible Party for Maintenance: Owner

- | COMPLETE                            | N/A                      |                                      |
|-------------------------------------|--------------------------|--------------------------------------|
| <input checked="" type="checkbox"/> | <input type="checkbox"/> | 1. Design criteria provided          |
| <input checked="" type="checkbox"/> | <input type="checkbox"/> | 2. Appropriate application           |
| <input checked="" type="checkbox"/> | <input type="checkbox"/> | 3. Shown as public or private        |
| <input checked="" type="checkbox"/> | <input type="checkbox"/> | 4. Coordinated with drainage plan    |
| <input checked="" type="checkbox"/> | <input type="checkbox"/> | 5. Coordinated with landscaping plan |

Miscellaneous Items and Notes:

None

Engineer of Record Signature: Bob Bobson

Date: 12-1-2019

The following checklist is provided as a guide for the submission of documents, exhibits, and field notes for required land acquisition for Capital Improvement Projects. In the event of any questions, please contact the assigned City Project Manager or Naomi Michaud ([nmichaud@mckinneytexas.org](mailto:nmichaud@mckinneytexas.org)).

## Checklist

### 1. Develop Land Acquisition Strip Map Minimum Requirements (If required per contract)

- Surveyed topographic features and/or recent aerial imagery – dated (per direction from City Project Manager).
- Existing right-of-way or easements depicted and labeled.
- Property boundaries depicted and numbered sequentially (if applicable) with parcel ownership information.
- Key proposed improvements depicted in a manner that does not clutter areas of proposed land acquisition need.
- Proposed right-of-way, permanent easements, or temporary easements (parcels) shaded/colored (by type) and labeled.
- Legend, scale, north arrow, stationing, and match lines (if applicable).
- Separate document (if requested from City) including overall project land acquisition summary (Parcel Number, Acquisition Types, Ownership Information, and Measured Acquisition Area).

### 2. Verify Necessary Property Need

- Proposed right-of-way and/or easements developed in accordance with the Engineering Design Manual.
- Consideration of temporary construction easements, if required, for construction (Including estimated timeframe of temporary easement need). Identify any known or potential minor physical alternations within temporary construction easements if required for construction purposes.
- Consideration of permanent slope easement(s) or access easement(s), if required, outside of right-of-way.
- Provide intersection right-of-way corner clips per Engineering Design Manual, if required, unless approved otherwise.
- Establish appropriate easement type/use (Drainage, Utility, Pedestrian, Etc.).
- Consideration of temporary construction right-of-entry needs (Where necessary and not captured/required under other easements).

### 3. Submission Requirements for Preliminary OR Final Exhibits to City:

- Verify parcel ownership information – Confirm no change in ownership or update exhibits / field notes /deeds accordingly.
- Provide survey field notes (Including most recent vesting deed) .
- Include property ownership and county recording information (including instrument and conveyance date) in the preamble and the drawing of the field notes.
- Exhibits and field notes are provided PER TRACT (even if adjoining tracts are under same ownership).
- Exhibits and field notes are provided PER TYPE if multiple easements are required on a single parcel/tract.
- Survey area closes (Provide closure sheet).
- Verify no typos present.
- Exhibit and written field notes match (Legal Name, Acreage, Type, Calls, Etc.).
- Parcels are numbered consistently (e.g. Parcel 1-ROW, Parcel 1-DE, Parcel 1-TCE). Do not use different numbers for the same parcel.
- Do not label survey exhibits/field notes as “Exhibit A” , “Exhibit B” , etc.
- Location Maps are not required but if provided include it as a separate document and not as a numbered page of the exhibits/field notes.