

# Zipline in McKinney, TX



Planning & Zoning Commission

March 2025



# Walmart Introduction

# Kimley Horn Site Plan Review

# Kimley-Horn Site Plan Review

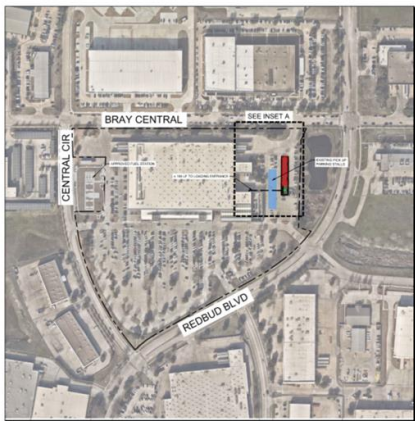

NOTES

GENERAL SITE DATA	
DATE SUBMITTED:	08/17/2023
PROJECT NAME:	WALMART STORE #206-1007
PROJECT ADDRESS:	206 S BRAY CENTRAL, MOCKINNEY, TX 75062
PROJECT CONTACT:	WALMART STORE #206-1007



SEE INSET A FOR DIMENSIONS AND LOCATIONS OF EXISTING AND PROPOSED

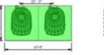

EXISTING AND PROPOSED DIMENSIONS AND LOCATIONS OF EXISTING AND PROPOSED

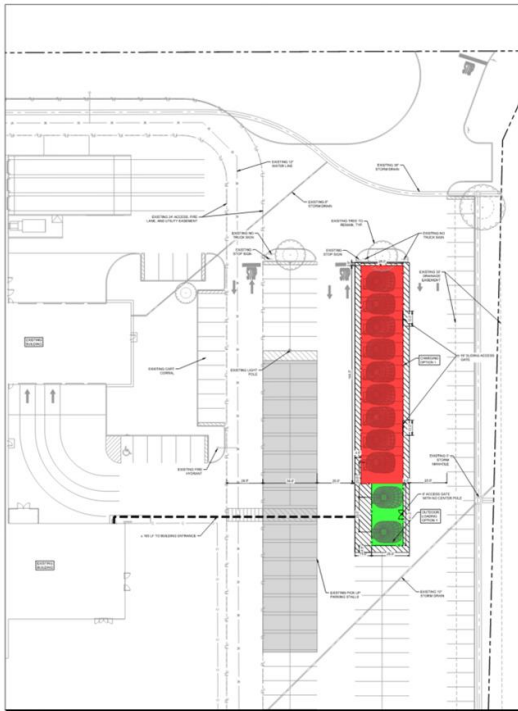

INSET A

SCALE: 1"=20'

PARKING INFORMATION																					
WALMART BUILDING INFO		AMU PARKING REQUIRED		WALMART PARKING PROVIDED		REGULAR PARKING STALLS PROVIDED		OSP PARKING STALLS PROVIDED		ZIPUNE PARKING STALLS PROVIDED		ADA PARKING STALLS PROVIDED		CART CORRAL STALLS PROVIDED		TOTAL STALLS PROVIDED		TOTAL AMU PARKING RATIO		TOTAL WALMART PARKING RATIO	
WALMART	BUILDING SF <sup>1</sup>	SPACES	SPACES	SPACES <sup>2,3</sup>	SPACES <sup>2,3</sup>	SPACES <sup>2,3</sup>	SPACES <sup>2,3</sup>	SPACES <sup>2,3</sup>	SPACES <sup>2,3</sup>	SPACES <sup>2,3</sup>	SPACES <sup>2,3</sup>	SPACES <sup>2,3</sup>	SPACES <sup>2,3</sup>	SPACES <sup>2,3</sup>	SPACES <sup>2,3</sup>	SPACES <sup>2,3</sup>	SPACES <sup>2,3</sup>	SPACES <sup>2,3</sup>	SPACES <sup>2,3</sup>	SPACES <sup>2,3</sup>	
EXISTING	206,550 SF	826 SPACES 1,002/250 SF	826 SPACES 4,002/1,000 SF	947	30	0	21	30	998	1.23/250 SF	4.83/1,000 SF										
PROPOSED	206,550 SF	826 SPACES 1,002/250 SF	826 SPACES 4,002/1,000 SF	907	30	40	21	30	958	1.16/250 SF	4.64/1,000 SF										

**CALCULATION INFORMATION NOTES:**  
 1. EXISTING PARKING COUNTS ARE BASED ON ORIGINAL CONSTRUCTION PLANS AND A REVIEW OF AVAILABLE AERIAL PHOTOGRAPHY.  
 2. PARKING SPACES OCCUPIED BY CART CORRALS AND ZIPUNE HAVE BEEN EXCLUDED FROM THE PARKING COUNTS AND PARKING RATIOS.  
 3. PARKING AND STORAGE OF VEHICLES, EQUIPMENT, OR STAGING AREAS OUTSIDE OF THE FENCED AREA IS NOT ALLOWED.  
 4. REQUIRED: AMU PARKING FROM CHAPTER-146-ZONING-REGULATIONS-SECTION 146-130 VEHICLE PARKING OF MOCKINNEY CITY CODE

## DESIGN / CODE SUMMARY

REDUCTION OF PARKING STALLS:  
 OPTION 1 - 40 STALLS

ENTITLEMENT SUMMARY:  
 - PORTFOLIO HAS NOT REVIEWED FOR ECR REQUIREMENTS  
 - NO CODE CALL HAS BEEN SET FOR THIS SITE  
 - BUILDING SQUARE FOOTAGE IS BASED ON MFC PLANS THAT IS DIFFERENT FROM LUCERNE-X

## DISCLAIMERS

WALMART DESIGN CONCEPT ONLY

WALMART CONCEPTS HAVE NOT REVIEWED TO VERIFY PROPOSAL AS OF 8/17/2023

SCOPE TRIP: MIDDYTT  
 PROJECTED ENTITLEMENT SUBMITTAL: MIDDYTT  
 PROJECTED ENTITLEMENT APPROVAL: MIDDYTT  
 PROJECTED PHO: MIDDYTT  
 PROJECTED PERMIT APPROVAL: MIDDYTT  
 POSSESSION DATE: MIDDYTT  
 CONSTRUCTION COMPLETE: MIDDYTT



ZIPUNE PLAN CONCEPT

5/2024

**#206-1007**  
 MCKINNEY, TX

**KimleyHorn**



# Zipline Drone Technology Overview

# Zipline is the world's largest drone delivery service



**1.2M+** commercial drone deliveries



**1,700 deliveries daily;** one every **65 seconds**



**85M+** miles of autonomous flight



**Zero-emission, sustainable delivery**

# Zipline has been delivering in Pea Ridge, AR since 2021

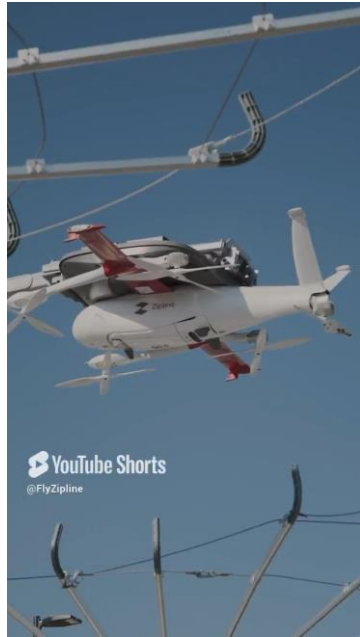

**First** P2 delivery in January 2025  
to the local Fire Department



"don't miss this opportunity for  
Economic Development growth"  
**Mayor Nathan See**

# Zipline is launching at scale in DFW



**20+** sites under development

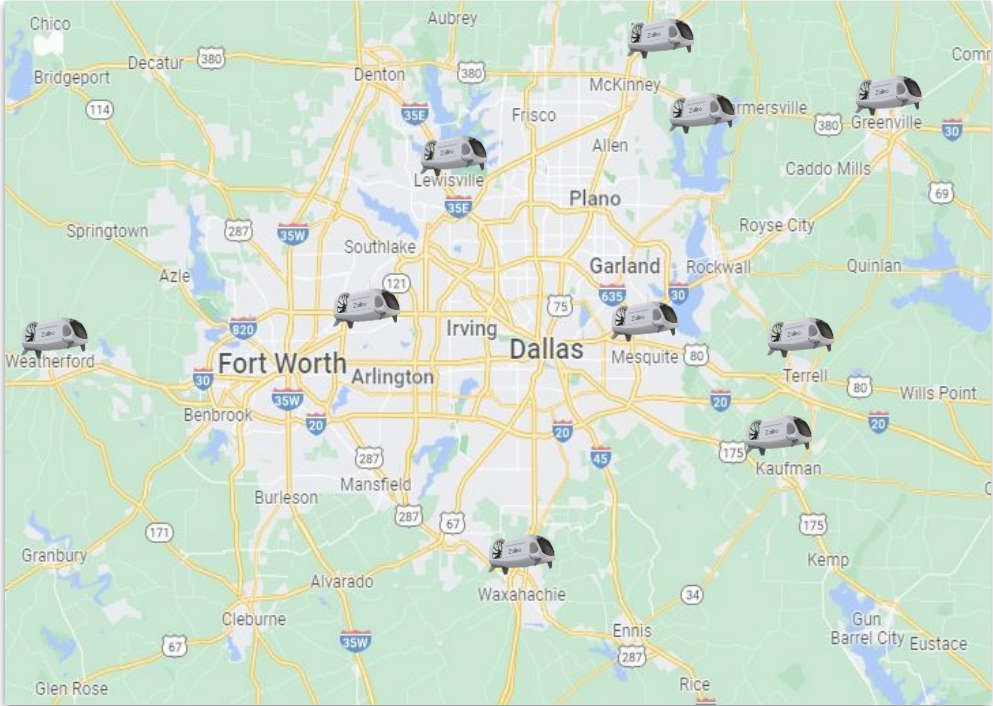

**10+** approved permits\*

*\*map is not representative of exact locations*



**5+** sites under construction





# Zipline helps communities everyday



Saves time



Safer roads



Reduced traffic



Economic opportunities



Improved access

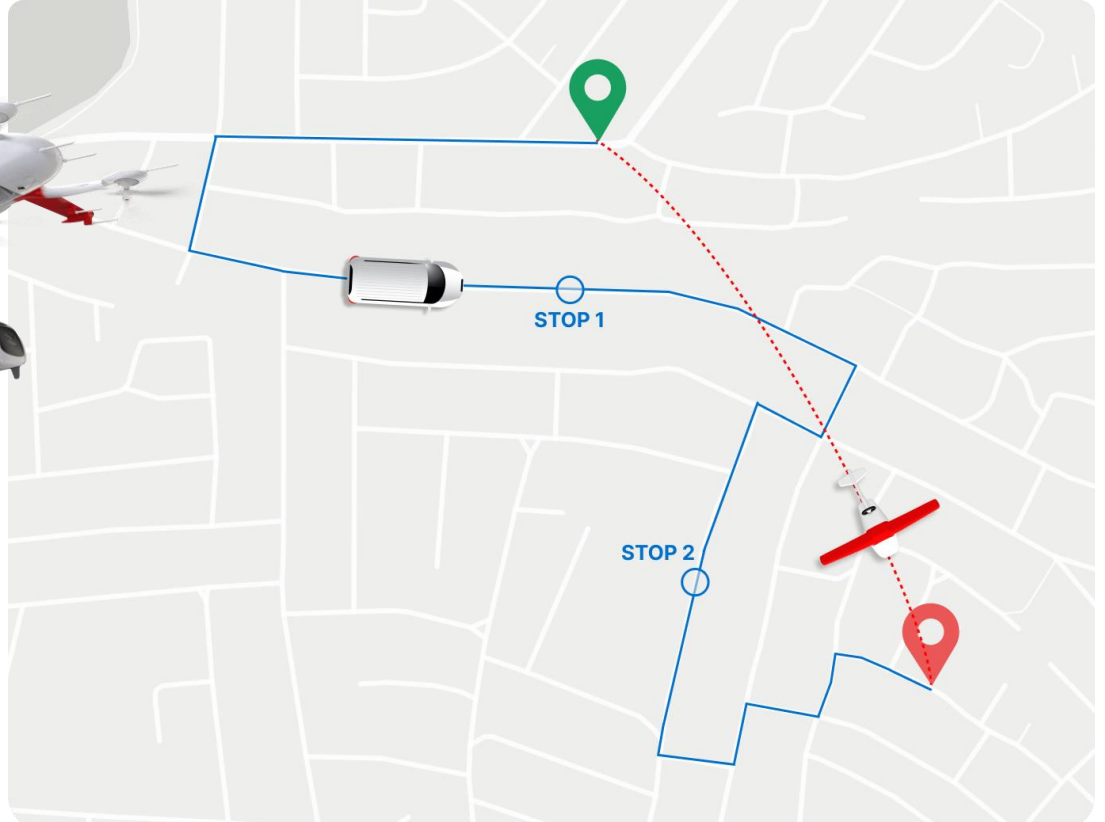



# Our Zip platform



## Technology Overview

Hyper-precise home delivery



- **Fully Autonomous**
- **Delivery:** Zip + ultra-precise delivery droid
- **Payload:** Up to 8 pounds
- **Service Radius:** Up to 10 miles service radius
- **Speed:** Up to 70mph
- **Wingspan:** 8 feet

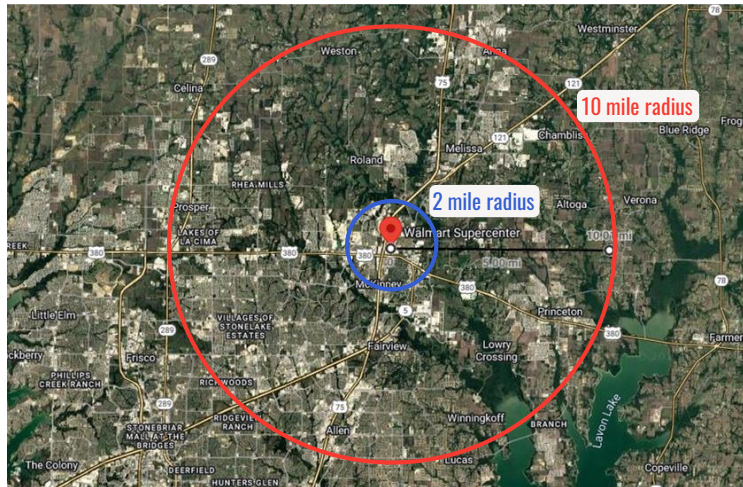
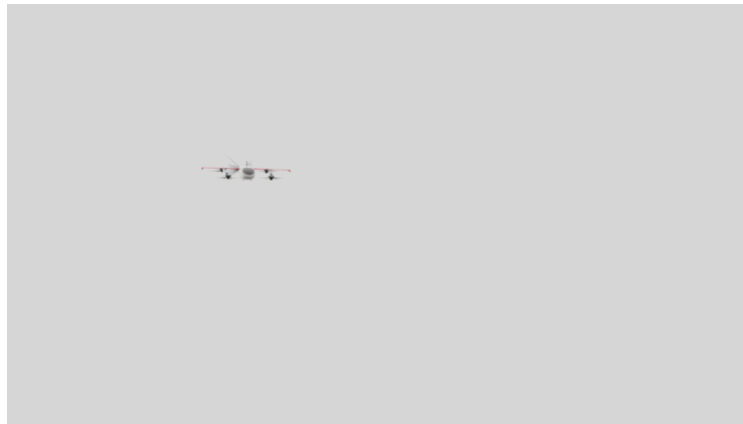

# A cute but mighty delivery droid



Food



Electronics



Grocery

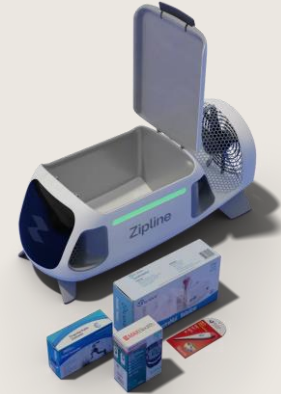

Health & Wellness

# Zips are quieter than common neighborhood sounds

## Docking



100 ft away

Zip with no payload

53 dB(A)

Zip with max payload

64 dB(A)

## Delivery



~300 ft



At delivery point

Zip delivery

<60 dB(A)

dB(A)

100

8X AS LOUD

JET FLYOVER AT 1000 FT

90

4X AS LOUD

PASSING MOTORCYCLE AT 15 FT

80

2X AS LOUD

FOOD BLENDER AT 3 FT

70

REFERENCE

TRUCK AT 50 FT

GARBAGE DISPOSAL AT 3 FT

VACUUM CLEANER AT 10 FT

LAWNMOWER AT 100 FT

60

1/2 AS LOUD

NORMAL CONVERSATION

CAR TRAFFIC AT 300 FT

50

1/4 AS LOUD

DISHWASHER NEXT ROOM

REFRIGERATOR NEXT ROOM

CONFERENCE ROOM

40

LIBRARY

30

RUSTLING LEAVES

# Zipline has safely flown over 100 million miles



## How we design

- Built-in critical system redundancies
- Two-part architecture
- Reliable materials



## How we test

- Rigorously tested in extreme weather
- Extensive quality assurance and real-world testing



## How we operate

- FAA certified just like major airlines
- Expert team tracks, manages, and maintains fleet 24/7



## How we fly

- 500+ automated pre-flight safety inspections
- FlightIQ Autonomy and Perception System

# Zips use FlightIQ, our autonomy and perception suite that make flights and deliveries smarter and safer

- Designed for flight and delivery purposes
- Applies industry-standard tools to blur faces in visual data
- Cannot zoom or be pointed in a particular direction
- Does not identify individuals or read license plates

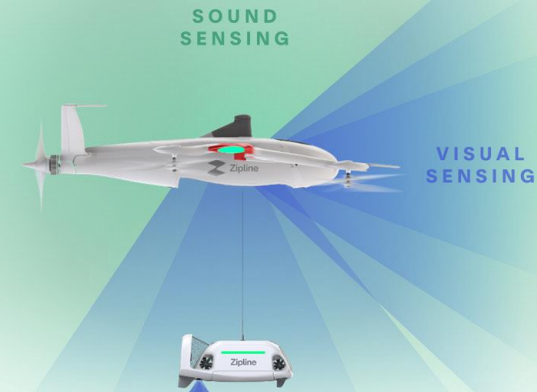
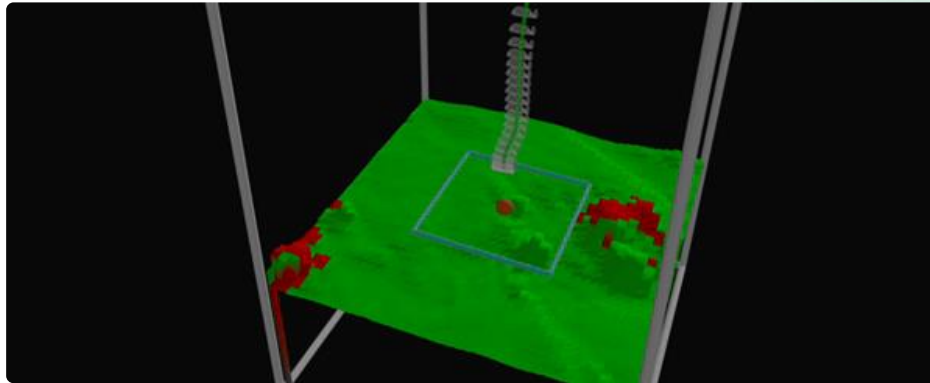

# Site infrastructure – single & double dock towers

## Single docks

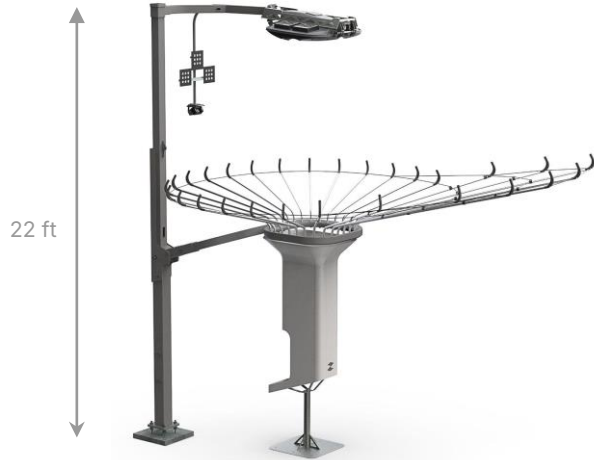

Single Docking Structure with Kiosk (x2)

## Double docks

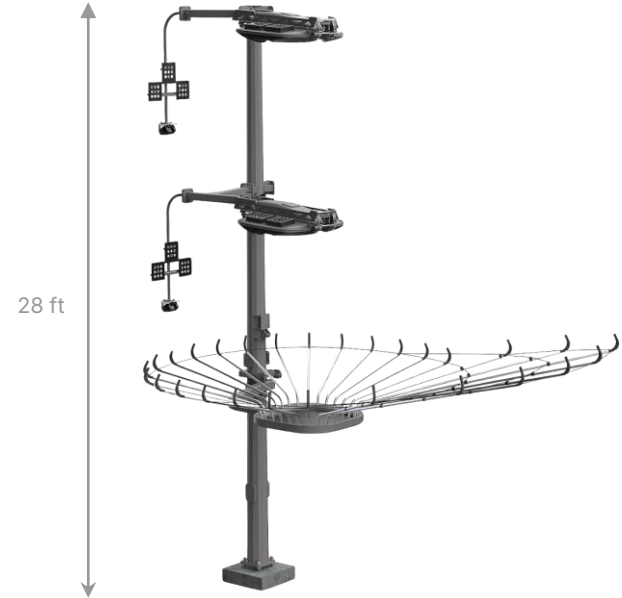

Double Docking Charging Structure (x9)



# Community engagement



thank you for coming in, I like how you're not just "trying" to change the world, but actually doing something to change the world



Want to get in touch?  
Email us at [DFW@flyzipline.com](mailto:DFW@flyzipline.com). We'd love to hear from you!

Thank you!

